

ESA 2010 Methodological note

Foreign trade reported by non-residents

Recommendations for compilers of national accounts and balance of payment statistics to follow the principle of change of economic ownership as required by ESA 2010 and BPM6 in case of foreign trade reported by non-residents.

This note has been approved by the Directors of Macro-Economic Statistics (DMES) in their meeting on 25-26 June 2015.

Contents

Contents	1
List of abbreviations and acronyms	2
1. Introduction - <i>general</i>	3
2. Introduction - <i>issue</i>	5
3. Recommendations	8
3.1 General recommendations	8
3.2 Identification of non-resident units	9
3.3 Exclusion of transactions of the non-resident units concerned (without resident units being involved)	10
3.4 Inclusion of transactions of resident units with the non-resident units concerned.....	13
3.5 Mirror transactions - Residents in the role of non-resident registered for VAT in other Member States	16
Annex A Composition of the Expert Group:.....	19
Annex B Numerical examples.....	20
Annex C Useful sources	22
Annex D Definitions/explanations	23

List of abbreviations and acronyms

BPM6	Balance of Payments Manual, sixth edition
CIF	Cost, insurance and freight
DMES	Directors of Macroeconomic Statistics
EORI number	Economic Operator Registration and Identification number
ESA 2010	European System of Accounts 2010
FOB	Free on board
IMTS	International Merchandise Trade Statistics
ITSS	International Trade in Service Statistics
NA/BoP	National Accounts/Balance of Payments
NAWG	National Accounts Working Group
NoT	Nature of Transactions
2008 SNA	System of National Accounts 2008
VAT	Value Added Tax

Foreign trade reported by non-residents

1. Introduction - *general*

Issues related to foreign trade reported by non-residents were discussed at two workshops held in Prague in 2012 and 2013. At its meeting of 16-17 September 2013, the Directors of Macroeconomic Statistics (DMES) agreed to address the issue of trade activities of non-residents registered only for VAT purposes.

The first step of this investigation was to collect information on Member States' activities using a questionnaire that was developed during the workshop held in June 2013 in Prague. The Manual on goods sent abroad for processing recommends that non-resident VAT traders' movement of goods is treated as a form of quasi-transit trade¹. Traditionally, quasi-transit trade was only recognised in case of trade with non-EU countries. This phenomenon now appears to also include trade flows between EU Member States. The goal of the questionnaire was to collect countries' compilation practices.

The detailed results of the questionnaire were presented to the National Accounts Working Group (NAWG) at its meeting of 22-23 May 2014. The results of the questionnaire indicated that applying the manual's rule – recording as quasi-transit trade – in a comparable way in all Member States, would require further work. There was a need for additional practical recommendations in order to help compilers of national accounts (NA) and balance of payment (BoP) statistics to follow the principle of change of economic ownership as required by ESA 2010 and BPM6. This would consequently improve the comparability. To prepare such a set of recommendations, the DMES in their meeting of 13-14 March 2014 agreed that an expert group with a limited number of Member States would be set up.

The meeting of the expert group was organised on 11 November 2014 in Luxembourg (see Annex A for the list of participants). The recommendations in this document were prepared at this meeting and finalised by written procedure.

Before moving to the issue itself, it is important to emphasise that the subject of foreign trade reported by non-residents should be distinguished from goods sent abroad for processing. Although discussions on the first topic started in the Task Force on Goods sent abroad for processing, it concerns two different issues. For both issues there is an absence of change of economic ownership while the goods are moving across the borders (and thus are recorded by primary data sources). In other words, for both issues, the initial data source includes movements of goods across borders that cannot be considered as exports or imports of goods (under ESA 2010/BPM6). Nonetheless, there is a difference between goods sent abroad for processing and the issue discussed here. In the case of goods sent abroad for processing there is a relation to manufacturing processes in the compiling economy because a resident unit provides services (or is a principal). Whereas the issue

¹ See the definition of quasi-transit trade in footnote 7

discussed in this paper is mainly about non-resident traders shifting their goods from the production place to final customers regardless of borders (often without any relation to manufacturing processes or, if related to manufacturing, then the values reported at the borders are different from real trade values).

It should also be noted that the well-known and so-called 'Rotterdam effect' is only one special case of the phenomenon this document is focused on: the impact of the single market and its legislation on the estimation of trade between residents and non-residents, namely the impact of non-residents trading in a domestic economy and taking part in cross-border movements of goods recorded in International Merchandise Trade Statistics (IMTS).

In this report national accounts and balance of payments statistics are mentioned in one breath (NA/BoP). However, there is one exception. Member States have to deliver BoP data to Eurostat according to the *national* concept as well as according to the *Community* concept. Quasi-transit trade should not be excluded for the Community concept. In the latter case, the item branding is included in the goods account to adjust for the difference between the value of the goods imported and re-exported from the compiling economy.

Even though the discussed issue is related to foreign traders registered for VAT, the recommended methodological solution, the ultimate change of economic ownership principle, is universal and should be followed even in cases when non-resident units are not registered for VAT. These cases, although rare, may happen and a practical solution may be even more complicated, but tax practice cannot undermine the statistical principles involved.

Finally, two remarks concerning the limitations of this report. First, the issue of compilation of European aggregates (either EU or euro area) has not yet been fully addressed. Non-residents from the national point of view are either residents or non-residents of the EU (or euro area). Only non-residents that are not resident in any other EU Member State should be considered as non-resident at the European level. And analogically, non-residents (at national level) that are resident in another EU Member State should be taken into account for European aggregates since they should be considered as resident at the European level. The second remark concerns the changing situation regarding data sources. There is a discussion under way about significant changes of the system of data collection in IMTS. This may change the availability of data for NA/BoP compilers.

2. Introduction - issue

ESA 2010 states:

- Exports of goods and services consist of transactions in goods and services (sales, barter, and gifts) from residents to non-residents (paragraph 3.158).
- Imports of goods and services consist of transactions in goods and services (purchases, barter, and gifts) from non-residents to residents (paragraph 3.159).
- Imports and exports of goods occur when economic ownership of goods changes between residents and non-residents. This applies irrespective of corresponding physical movements of goods across frontiers (paragraph 3.162).

Even though physical movement of goods is not relevant for the compilation of foreign trade in NA and BoP, generally the main data source used for the compilation is International Merchandise Trade Statistics (IMTS)² which are based on cross-border movements. IMTS figures, physical movement of goods, were traditionally used as a proxy for the change of ownership between residents and non-residents, i.e. estimation of foreign trade in NA and BoP. However, a single market in the EU with its common VAT system³ and highly harmonised data collection of IMTS⁴, reduces the link between the physical movements of goods and the change of ownership. Foreign traders can trade freely within each Member State's economy or across all Member States. Therefore, there may be cross-border movements of goods without any change of economic ownership between residents and non-residents (see figure 2.2) and also trade between residents and non-residents without cross-border movements (see figure 2.3).

Simple diagrams can help to explain the issue.

Figure 2.1 A non-resident unit importing and exporting to and from the compiling economy

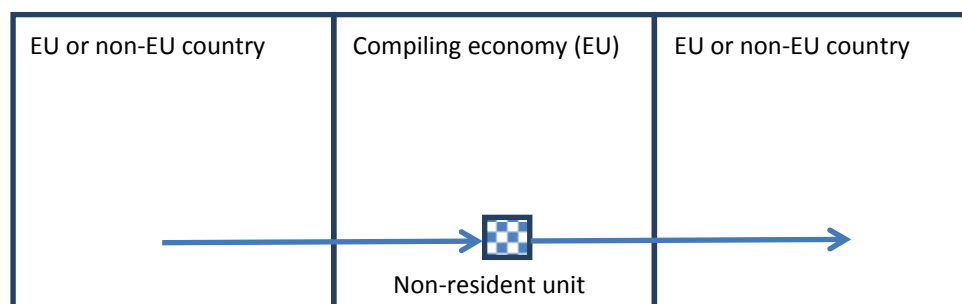

A non-resident unit imports/exports⁵ goods to/from the compiling economy (see figure 2.1). This non-resident unit is registered in the compiling economy for VAT but has no physical presence in the economy concerned; it has no employees, no premises and no production activities. Its activities are

² Which are also called International Trade in Goods Statistics (ITGS) and consist in the EU of Intrastat and Customs declarations (Extrastat).

³ VAT Directive 2006/112/EC (for country specifics; see country legislation).

⁴ ITGS User Guide (for country specifics; see country manuals).

⁵ In this case, the terms 'imports' and 'exports' mean physical movement of goods across the borders (inflow and outflow of goods into/from the economic territory of the compiling economy). It is not used in the sense of national accounts definitions of imports and exports.

limited to trading⁶. The goods could be stored in the compiling economy, by renting these services from resident units. If an entity provides these activities itself, it is more likely a resident unit. An important issue is that the value of the goods leaving the country often differs substantially from the value of the goods entering the country i.e. by trade margins, branding or holding gains/losses. Whatever the reason for the difference between the two values, it is not output of the compiling economy and so cannot be recorded as such.

Although in the case described above there is a physical movement of goods across borders, there is no transaction between a resident and a non-resident unit, no change of economic ownership. Since the physical movement across borders is registered in the IMTS (if according to Community concept), for the national accounts as well as for the balance of payments (according to the national concept, not according to the Community concept), these flows **should be excluded**, that is: treated as transit trade (see figure 2.2). The flows are usually referred to as quasi-transit trade and similar operations⁷.

Figure 2.2 Excluding IMTS data for national accounts/balance of payments

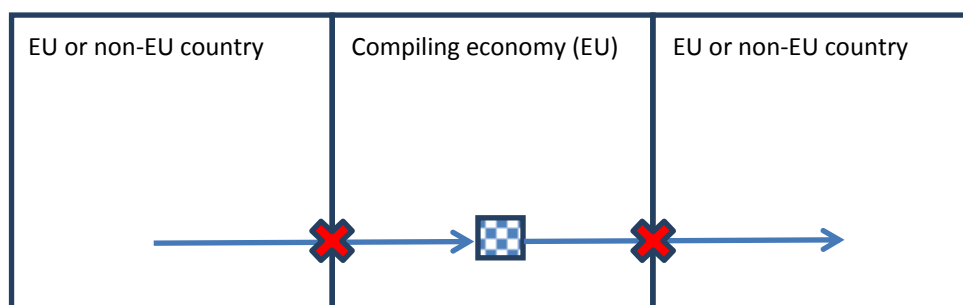

In practice the situation can be more complicated. Residents and non-residents may trade with each other within a compiling economy. In these cases, no cross-border movements of goods occur, so these transactions are not recorded in IMTS. Therefore, they are not taken into account when compiling foreign trade using exclusively IMTS data sources.

For a better understanding of the issue, see figure 2.3. The foreign trader (=non-resident unit) can purchase/sell the goods from/to a resident unit. These transactions between a resident unit and a

⁶ Possibly, the foreign trader concerned may be represented by a tax representative, who would act on behalf of the trader. In practice, it is necessary to distinguish between transactions related to the own activity of a tax representative and those of the foreign trader. In some countries separate VAT returns may be submitted, in some there may be only one document incorporating activities of tax representative and its deputised customers.

⁷ Quasi-transit trade in a broader definition as 'goods transported into a country A by a non-resident (recorded as imports in IMTS) and then sent from the country A by a non-resident (recorded as exports in IMTS)'. The term 'quasi-transit trade' was, until recently, and followed by ESA 2010, defined in the EU as 'goods imported into a country from a non-EU country, cleared through Customs for free circulation within the EU, and then dispatched to a third country in the EU'. However, this economic phenomenon is not limited only to the trade with non-EU countries but could happen also within the EU (goods arriving from one Member State and dispatched to another by a non-resident). For this phenomenon within the EU, there was no term agreed either at the time of preparation of the Manual on goods sent abroad for processing or at the time of preparation of the questionnaire. That is why there has been a terminology inconsistency in the past. In the Manual, the phenomenon was introduced under the term 'non-resident transit trade', in the questionnaire under 'similar operations to quasi-transit trade'. This document recommends treating both described phenomena (either from non-EU or within the EU) under the term 'quasi-transit trade' since there is no difference in economic sense of both issues. There may be only practical differences.

non-resident unit **should be included** in the national accounts and the balance of payments because there is actually a change of economic ownership between a resident and a non-resident.

Figure 2.3 A non-resident unit trading with resident units

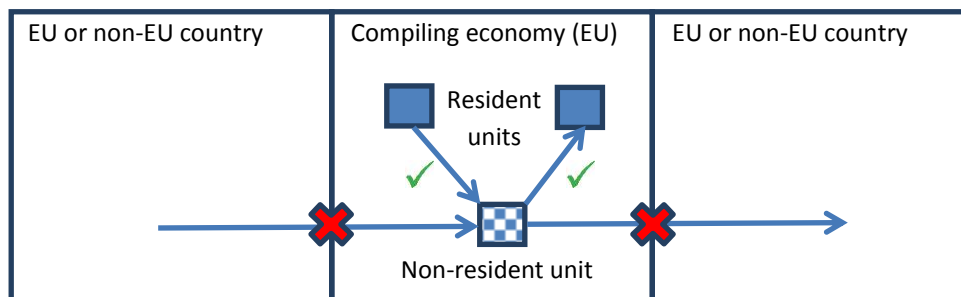

Conclusions:

The impact of single market rules on the compilation of foreign trade in the EU for the NA and BoP can be divided into two separated, but complementary, issues:

First, there are movements of goods recorded in IMTS that imply no change of ownership, i.e. cross-border transactions reported by non-residents. Cross-border transactions reported by non-residents should be **excluded** from imports and exports of goods in NA and BoP⁸ (see the red **X** crosses in figure 2.3).

Second, there are transactions between residents and non-residents in the compiling economy (i.e. change of economic ownership occurs) without any cross-border movements recorded in the IMTS. These transactions should be **included** into imports and exports in NA and BoP (see the green **✓** marks in figure 2.3). In such cases, for BoP purposes, as well as for the compilation of European aggregates (e.g. EU and euro area) it is of importance to establish the country of residence of the non-resident to establish the geography of the transaction.

⁸ There may be various reasons why a non-resident physically moves the goods into/out of the territory of the compiling economy. That is why the Nature of Transaction reported by non-resident units may take a wide range of codes. Nonetheless, no matter what the reason (NoT code) is, the cross-border movement of goods itself reported by any non-resident should be excluded from exports and imports in NA/BoP. Here are some examples of reasons for cross-border movements of goods by non-residents:

- a) storage of goods in a distribution centre in the compiling economy with a subsequent outflow of goods (quasi-transit trade);
- b) handover of goods for processing (provided by a resident processor) with subsequent handover of processed goods back to the non-resident principal who sells the goods in the compiling economy or abroad (in practice, the reported NoT code may not be related to goods sent abroad for processing);
- c) trade with the goods in the domestic market of the compiling economy (i.e. sales following the inflow of goods or purchases preceding the outflow of goods in/from the territory of the compiling economy).

Example b) shows that the issue of foreign trade is related also to the issue of goods sent for processing (since it affects the collection of primary data – IMTS) but they should not be equated.

3. Recommendations

In section 3.1 a number of general recommendations are made. They are specifically focussed on the treatment of cross-border flows reported by non-residents and their transactions with residents in the compiling economy.

The recommendations concerning the recognition of non-resident units are listed in section 3.2, the recommendations concerning the exclusion of cross-border movement of goods reported by non-resident units are listed in section 3.3 and the recommendations concerning transactions of non-resident units with resident units, when a change of economic ownership occurs without cross-border movements, are listed in section 3.4. Section 3.5 gives recommendations on so-called mirror transactions; residents in the role of non-residents registered for VAT in other Member States.

In general, the issue of foreign trade reported by non-resident units is about trade in goods. However, trade in services could be involved. In section 3.4 therefore, separate recommendations are devoted to the issue of trade in services with non-resident units.

The aim of the work of the expert group was to compile practical recommendations. However, possible data sources in the Member States are quite heterogeneous. For instance, the level of detail of the VAT returns is not standardised in the EU. Therefore, the recommendations have to be rather generic.

3.1 General recommendations

1. *The data on the physical cross-border movements of goods only can serve as a starting point for the compilation of NA/BoP imports and exports. Because of the strict application of the change of economic ownership principle in ESA 2010/BPM6 the IMTS data need to be adjusted.*
2. *Cross-border movements of goods reported by non-resident units⁹ into IMTS have no relevance for the reporting economy from the NA/BoP perspective. When compiling foreign trade figures for NA/BoP these physical flows should be **excluded** as there is no change of economic ownership.*
3. *Transactions of non-resident units with resident units, when a change of economic ownership occurs, should be **included** when compiling foreign trade figures for NA/BoP.*
4. *Every entity (EU or non-EU) can have a registration for VAT purposes in every Member State. Sole registration for VAT (and/or assignment of an EORI¹⁰ number) does not imply residency according to NA/BoP concepts in the country of registration.*
5. *In every EU Member State non-resident units may carry out transactions affecting compilation of foreign trade figures in NA/BoP. The magnitude of the impact can differ but every Member State should examine this issue.*

⁹ These units may or may not be registered for VAT purposes only.

¹⁰ EORI number – Economic Operator Registration and Identification number – for more information, see section 3.2

3.2 Identification of non-resident units

6. *In order to compile foreign trade according to NA/BoP concepts (ESA 2010/BPM6), non-resident units must be identified in the relevant data sources. The way non-resident units can be identified depends on the available data source and varies from Member State to Member State. Main data sources for identifying non-resident units are VAT register, Business register, Tax register, EORI register and employment data¹¹. In general, one cannot rely on one source only. Especially in the case of units with substantial impact, several sources should be combined to decide whether an entity is resident or non-resident according to NA/BoP concepts¹².*
7. *In IMTS data sources, units are reporting their transactions under VAT number (for Intrastat) and EORI number (for Extrastat). Each unit has a different VAT number in each Member State where the unit is registered for VAT purposes¹³. The EORI number is unique for each unit across the EU¹⁴.*
8. *As for Intrastat, in some Member States non-resident units can be identified by a special VAT identification number¹⁵, nonetheless, verification by other data sources is usually needed.*
9. *In the case of Extrastat, the country prefix of the EORI number could be the starting point for the identification of residency of the unit. However, as explained in footnote 13, this rule cannot be applied without further verification due to units seated outside the EU and country specifics in legislation and practice. There is also a question of identification of the owner of goods in the customs declaration, i.e. which unit stated in different fields of the customs declaration for each cross-border transaction indicates the unit with the right to treat the goods as an owner¹⁶.*
10. *Nature of Transaction (NoT) codes may also be helpful for the identification of transactions reported into IMTS that are conducted by non-resident traders in the compiling economy¹⁷. In some Member States a separate national NoT code is used for acquisition or dispatch of goods by companies registered for VAT only.*

¹¹ In some cases, not to be included in these data sources may imply non-residency.

¹² When identifying non-resident units it is not sufficient to simply identify them as non-resident. For BoP purposes it is paramount to also identify the specific country of residence of each non-resident unit. This information is essential to compile the EU aggregates as well as the BoP current account with a correct geographical breakdown at the national level.

¹³ Each VAT number has a country prefix of the country of registration (not the country of residency of the unit). Therefore, the country prefix of the VAT number cannot help with identification of non-resident units. Each unit (if it is a provider of statistical information for Intrastat in Member State A) reports its cross-border transactions related to Member State A under the VAT number issued in that Member State. For example, if a unit has a VAT registration in both states (on both sides of the border) the export is reported under one VAT number (country of dispatch) and the import under another VAT number (country of arrivals), even though it is still one and the same unit.

¹⁴ Each unit receives its EORI number in the Member State of residency. In case of units seated outside the EU, they can apply for EORI registration in one (arbitrary) Member State. Each EORI number has a country prefix at the beginning of the country of registration. Therefore, there may be non-resident units (seated outside the EU) with EORI number with a country prefix of the domestic economy. For that reason it is not sufficient to identify a non-resident unit only 'technically' by the country prefix in the EORI number and additional data sources are needed.

¹⁵ Very often there is a specific tax authority office where foreign traders apply for registration for VAT. For more information, see the Vademecum on VAT obligations.

¹⁶ Custom declaration contains many data elements (Importer/Exporter, Declarant and Representative). Usually, for the IMTS the data elements Importer or Exporter is essential but they are not necessarily owners of the goods. Since a declarant is usually the unit on whose behalf (and in whose name) a representative acts and the VAT is declared in the customs declaration on its behalf as well, a declarant may seem to be closest to the owner status. Nonetheless, most frequently the Importer/Exporter and declarant is one and the same unit.

¹⁷ However, in any case no matter what NoT a non-resident reports in IMTS, its cross-border transactions are not relevant to the compilation of NA/BoP for the compiling economy.

11. *In VAT data sources, units submit their VAT return under their VAT number issued in the Member State where the VAT return is submitted (i.e. in the domestic economy where the taxable supplies were provided/received).*
12. *Non-resident units can appoint a tax representative¹⁸ that fulfils the VAT requirements. In some Member States this is obligatory. VAT returns of tax representatives usually distinguish between the representative and the companies represented.*
13. *In some countries, VAT groups exist. In such cases, there are many legal units integrated under one VAT number. In general, members of a VAT-group are residents of the Member State where the VAT group is registered.*
14. *It is recommended to investigate non-resident trader activities in the domestic economy at least once a year to check whether significant changes have occurred.*
15. *In specific, substantial, cases it can be necessary to contact individual non-resident merchants or their VAT representatives, or it may be helpful to contact their related or contractual resident parties.*

3.3 Exclusion of transactions of the non-resident units concerned (without resident units being involved)

The recommendations in this section focus on the exclusion of transactions of the non-resident units from the IMTS-data. Though there is a physical cross-border movement of goods, in the NA/BoP imports and exports these transactions should be excluded because there is no change of economic ownership between a resident and a non-resident unit.

16. *In a single market with a free movement of goods foreign traders can conduct cross-border movements of goods in each Member State. Their transactions may and may not have any relation to the compiling economy.*

Please find below a number of examples of these transactions (non-exhaustive):

Case a

A non-resident imports goods across the borders into the economic territory of a compiling economy, stores the goods in a central warehouse or distribution centre and subsequently exports the goods from the territory of the compiling economy to a final customer (see figure 3.1).

¹⁸ Similar issues arise with trade reported by resident *commission agents* who act as intermediaries between a principal – who is the owner of the goods – and a purchaser of the goods. In case the principal is a non-resident who imports goods into the compiling economy through the commission agent (imports in IMTS are reported under the VAT number of the resident commission agent), the imports should be removed from NA/BoP imports of goods and, in case of sales to resident units, replaced by estimates of those transactions.

Figure 3.1 Excluding IMTS data for NA/BoP

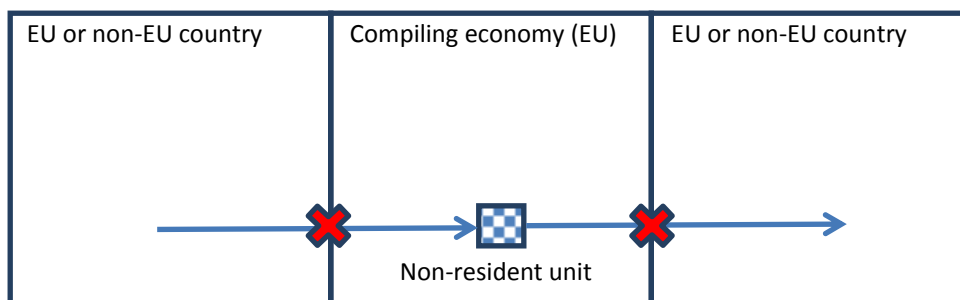

*This is an example of quasi-transit trade. There is no change of economic ownership between residents and non-residents. Both the inflow of goods (imports in IMTS) and outflow of goods (exports in IMTS) have to be **excluded** from imports and exports in NA/BoP.*

Very often the value of goods leaving the territory (exports in IMTS) differs from the value of goods when entering the territory (imports in IMTS)¹⁹. The only transaction between residents and non-residents consists of the value added services provided by residents to non-residents (rental of warehouse, packaging, quality inspections, etc.; these exports of services for the compiling economy are not shown in the diagram).

Case b

A non-resident imports goods across the borders into the economic territory of a compiling economy and sells the goods in the domestic market to a resident unit²⁰ (see figure 3.2).

Figure 3.2 Excluding imports by a non-resident unit for NA/BoP

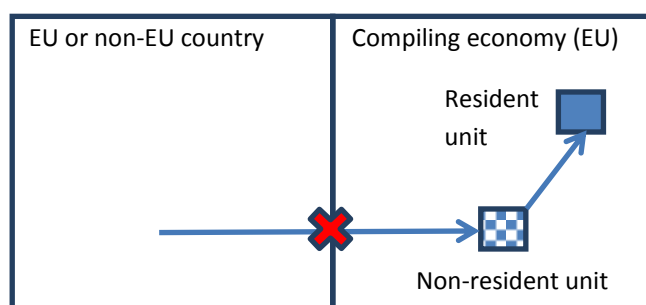

The value of goods entering the country (imports in IMTS) may differ from the real trade value between resident and non-resident in the domestic market. The change of economic ownership occurs at the time of the trade between resident and non-resident unit. The cross-border inflow

¹⁹ There may be many reasons for the difference. For example, the goods may be revalued by the non-resident owner from in-house prices to market prices for final customers, there may be holding gains/losses by the non-resident or there may have been some services provided by a resident unit (exports of services for the compiling economy). If units are related, transfer pricing can be involved. Either way the goods are not owned by residents and the change in value of goods owned by non-residents cannot be recorded in the compiling economy.

²⁰ In practice, very often a non-resident unit can sell the goods to another non-resident (often related and also registered for VAT in the compiling economy) and this new non-resident owner subsequently exports the goods. This case should be treated analogically to case (a). Transactions between non-residents are not relevant to the compiling economy.

of goods (recorded in IMTS as imports) cannot be considered as imports in NA/BoP and has to be **excluded**. When the goods are sold, the transaction between the non-resident and the resident has to be included (see section 3.4, case d).

Case c

A non-resident purchases goods from a resident in the domestic market and subsequently exports the goods from the compiling economy (see figure 3.3).

Figure 3.3 Excluding exports by a non-resident unit for NA/BoP

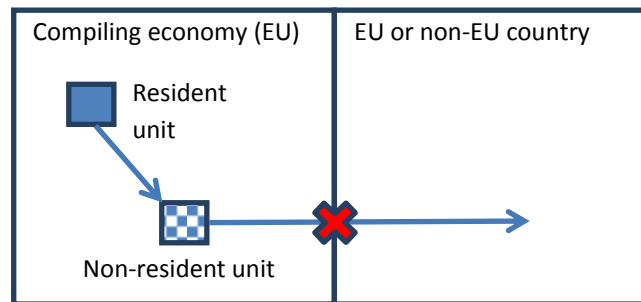

The value of goods leaving the country (exports in IMTS) may differ from the real trade value between resident and non-resident in the domestic market. The change of economic ownership occurs at the time of the trade between resident and non-resident. The cross-border outflow of goods (recorded in IMTS as exports) cannot be considered as exports in NA/BoP and has to be **excluded**. Instead, the purchase of the non-resident from the resident has to be included (see section 3.4, case e).

17. In practice, many different cases of cross-border transactions in goods conducted by non-resident units may occur. In any case, cross-border transactions reported by non-resident units are not relevant to the compiling economy and should be excluded from imports and exports in NA/BoP²¹.
18. To identify the transactions that should be excluded from the imports and exports (from Extrastat and Intrastat), use can be made of the special VAT ID number/EORI number for non-resident merchants.
19. Cross border flows reported by non-residents may cover also processing operations where the final products are sold either in the compiling economy or to non-residents from another country. In case of generic adjustments, compilers of NA/BoP should be aware of 'double exclusion'. Cross-border flows without change of ownership between a resident and a non-resident should be excluded. A transaction cannot (should not) be removed twice; once because the cross border flow concerns goods sent abroad for processing and once again because of non-resident trade.

²¹ In countries where case (a) is negligible and for cases (b) and (c) there is no difference between the value of goods at the borders (reported into IMTS) and the real trade value, the imports and exports in IMTS reported by non-resident units may still be used as a proxy for the compilation of imports and exports in NA/BoP. However, this may be only a rare situation.

3.4 Inclusion of transactions of resident units with the non-resident units concerned

Non-residents (may/may not be registered for VAT purposes) can carry out transactions without any physical cross-border movements taking place in the compiling economy. These transactions will not be recorded in the IMTS but should, according to ESA 2010/BPM6, be included in imports and exports figures of NA/BoP.

20. In a single market foreign traders can trade within each and every Member State, if they fulfil the administrative requirements. One of such requirements is usually a registration for VAT in the compiling economy²². Therefore, their (taxable) transactions²³ in the domestic economy are usually recorded in VAT returns submitted by foreign traders to the tax authority.

21. Please find below a number of examples of these transactions:

Case d (counterpart to case b)

A non-resident imports goods across the borders into the economic territory of a compiling economy and sells the goods in the domestic market to a resident (see figure 3.4).

Figure 3.4 Including sales of a non-resident unit to a resident unit

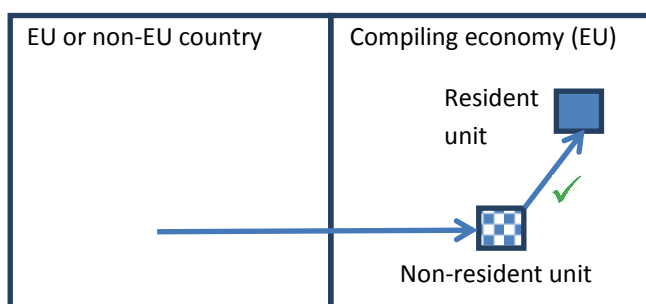

For the compiling economy, the value of the transaction in the domestic market (change of economic ownership from non-resident unit to resident unit) is relevant. These **sales** by non-resident units to resident units should be estimated by compilers of NA/BoP and considered as **imports** for the compiling economy. In addition, for BoP purposes, it is also necessary to estimate the specific countries of residence of the respective non-resident units.²⁴

Case e (counterpart to case c)

A non-resident purchases goods from a resident in the domestic market and subsequently exports the goods from the compiling economy (see figure 3.5).

²² Nonetheless, there may be some exceptions and country specifics.

²³ The activity of foreign traders registered for VAT is usually limited to trading and largely considered as taxable supplies. Nonetheless, there may be country exceptions that must be examined.

²⁴ Geographical breakdown of national BoP current account is a challenging issue not just because of non-residents trading within the domestic market but also because of merchanting and IMTS data source which provides only information on country of origin/dispatch/destination but omits the information on the residency of the business partner of the resident unit.

Figure 3.5 Including purchases of a non-resident unit from a resident unit

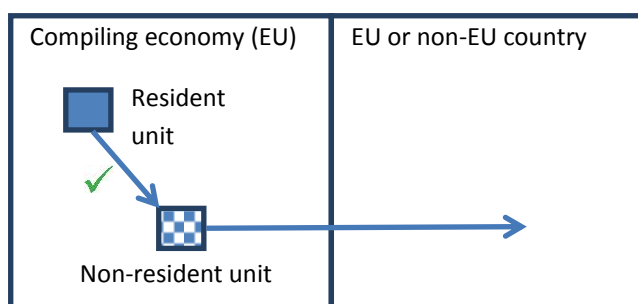

For the compiling economy, the value of the transaction in the domestic market (change of economic ownership from a resident unit to a non-resident unit) is relevant. These **purchases** by non-resident units from resident units should be estimated by compilers of NA /BoP and considered as **exports** for the compiling economy. An approximation of the specific countries of residency of the concerned non-resident units needs to be made for BoP compilation.

Case f

A non-resident purchases goods from a resident in the domestic market of the compiling economy and subsequently sells the goods in the domestic market to another resident (without the goods leaving the territory of the compiling economy)²⁵ (see figure 3.6).

Figure 3.6 Including purchases and sales of a non-resident unit from and to a resident unit

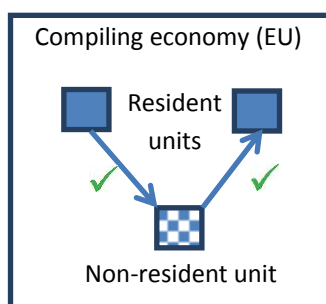

For the compiling economy, the value of the transaction in the domestic market (change of economic ownership from resident unit to non-resident unit and subsequently to another resident unit) is relevant. Treating these transactions analogously (but inverse) to 'regular' merchandising would imply that in NA/BoP the purchases and subsequent sales by non-resident units with resident units should be considered as negative imports and subsequent positive imports for the compiling economy. This prevents the exports and imports of the compiling economy from being inflated. However, strictly according to ESA 2010 (par. 18.41) and BPM6 (par. 10.45) rules, these

²⁵ This example is the reverse of merchandising and was introduced in the questionnaire under the term 'negative merchandising'. However, after additional discussion the terminology was changed to 'inverse merchandising'. In case of merchandising the goods do not enter the compiling economy; in case of inverse merchandising the goods do not leave the compiling economy.

purchases and sales should be included under general merchandise. In practice this is also most likely to happen: the purchase of the goods will be considered as exports and sales as imports (if the compilers of NA/BoP are unable to detect these transactions directly in primary data sources and distinguish them from cases d and e). A specific survey destined to fiscal representatives could be a solution. The question whether the recording of 'inverse merchanting' should deviate from the current guidelines should be discussed further in connection with BPM7 and should be put on the SNA research agenda.

22. *The main challenge for NA/BoP compilers is to estimate sales and purchases in the domestic market between residents and non-residents since they are not recorded in traditional data sources for imports and exports (i.e. in IMTS). It is not needed to additionally estimate these transactions for each case introduced above, i.e. separately sales for case (d) and (f) and separately purchases for cases (e) and (f). However, in practice it may be more suitable to keep them separate since a commodity breakdown of sales/purchases by non-residents is required.*
23. *The starting point for the estimation of sales and purchases may be VAT returns submitted by non-resident units: received/provided taxable supplies. VAT returns submitted by residents may not help since the taxable supplies are not usually split into transactions with residents and with non-residents²⁶.*
24. *Received/provided taxable supplies in VAT statements submitted by non-residents may include not only transactions in goods but also in services (depending on statements in each Member State). However, since there is a general reverse-charge rule for services²⁷, these services may be assumed to be macroeconomically insignificant. For practical reasons, it may not be possible to distinguish between goods and services in the original data source, but if possible, the services should be excluded from sales/purchases by non-residents in case of estimation of transactions in goods. This trade in services (between residents and non-residents) should be taken into account when compiling transactions in services, if they are not covered by any standard data source (like International Trade in Service Statistics (ITSS)²⁸).*
25. *Received/provided taxable supplies in VAT statements submitted by non-residents may include not only transactions with residents but also **with other non-residents** (so-called resales). Such transactions between non-residents are not relevant to the compiling economy but are defined as taxable supplies in VAT legislation and as such are included in VAT returns submitted by non-resident units. Resales inflate equally both purchases and sales of buyers and sellers. Especially if there are related non-residents registered for VAT in the compiling economy, these resales in primary data sources may be significant.*

²⁶ The data scope of VAT returns in each Member State may vary. Therefore, in some countries the tax base of received/provided taxable supplies of goods may be the basis for the estimation; in other countries alternative indicators may be needed.

²⁷ VAT Directive 2006/112/EC (including amendments!), Article 44.

²⁸ Concerning ITSS; in some countries surveys on foreign trade in services may include also non-residents. In other words, non-residents may report their services into primary data sources used for the compilation of services. In such a case, these services should be excluded because these transactions by non-residents (by definition) are not relevant for the compiling economy. This is analogously to the adjustment of 'raw data' collected by Intrastat/Extrastat for cross-border movements of goods by non-residents. This is in fact a general reminder that non-resident activities may be surveyed (by accident or on purpose) in the compiling economy and in such a case compilers have to examine this primary data source and the relevance of collected data to the compiling economy.

26. Compilers should investigate all domestic sales/purchases reported by non-residents and if the transaction is with a resident unit it should be classified either as imports/exports of goods (majority) or as imports/exports of services (minority). When it is not possible to identify transactions with residents (identify resales) or distinguish between goods and services from the original data source (= VAT statements by non-residents), it is recommended to include these transactions as imports/exports anyway. In this way the balance of trade in goods and services as a whole is as accurate as possible and with the least divergence of the breakdown in goods and services.
- If transactions between non-residents (resales) are not excluded from sales/purchases it will lead to an overestimation of imports and exports (equally on both sides in the total value of sales/purchases by all non-residents) but it would not affect the trade balance (since what is for one non-resident a sale is for another a purchase).
 - If the goods and services are mixed, it would deteriorate the breakdown but the trade balance of goods and services would not be affected.
27. In some countries, other data sources with questions for residents about trade in the domestic market with non-resident units may be available. Cross checking the obtained data with other sources is always recommendable.
28. Cross-border transactions reported by non-resident units into IMTS may also be helpful - at least for cases (d) and (e). If case (a)²⁹ is negligible in the compiling economy and a difference between the value of goods at the borders and in the domestic market in cases (b/d) and (c/e) can be estimated, then IMTS data reported by non-residents may be a base for the estimation of sales and purchases by non-resident units in the domestic market.
29. IMTS data cannot help with the estimation of sales/purchases in case (f).
30. For supply and use tables a commodity breakdown of sales/purchases by non-residents is required. If there is no direct data source (e.g. statistical survey), IMTS data reported by non-residents can be the starting point. However, the impact of this issue usually varies from commodity to commodity (from unit to unit) so additional study is needed. As for case (f) IMTS data source cannot help, so an alternative data source is needed. NACE codes of the companies involved may be helpful.

3.5 Mirror transactions - Residents in the role of non-resident registered for VAT in other Member States

In this section, recommendations are given concerning mirror transactions. Residents of a compiling economy can be registered for VAT in other Member States. Only if 'both sides' are covered correctly, including correct identification of the geographical counterparts for these transactions, asymmetries can be avoided and sound total EU aggregates be estimated.

31. Referring to section 3.3, case (a): A resident of a compiling economy (country A) is registered for VAT in Member State C (see figure 3.7). If this unit exports goods from economy B, through economy C (warehouse) to economy D, in the NA/BoP of economy C no imports and exports of

²⁹ Quasi-transit trade – see section 3.3.

goods should be registered. In country B export is registered vis-à-vis country A (purchases by non-resident), in country D import from country A is registered (sales by non-resident), and in country A **merchandising** transactions are registered (purchases from country B as negative export and sales as export of goods to country D under ESA 2010/BPM6). These transactions (in the compiling economy) are usually covered by data sources focused on merchandising transactions.

Figure 3.7 Mirror transactions to case a – merchandising, four countries involved

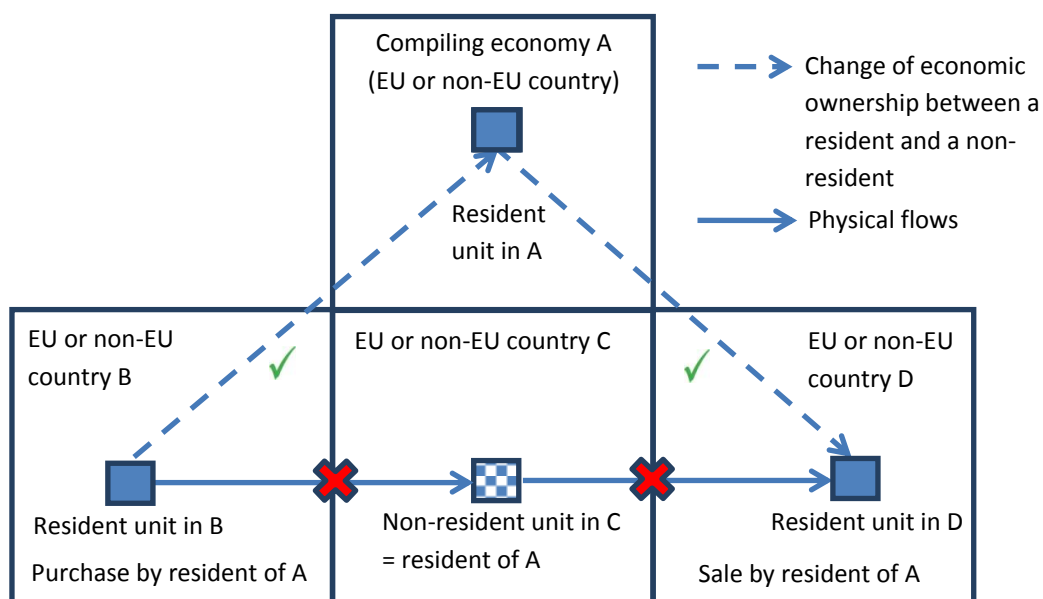

32. Referring to section 3.3, case (b) and section 3.4, case (d): A resident of a compiling economy is registered for VAT in Member State B (see figure 3.8). If this unit exports goods from the compiling economy to this other Member State, there is no export from the compiling economy when the goods cross the border but an **export** should be registered in NA/BoP when the goods are sold to a resident unit of this Member State B. For this case data are uneasily accessible, therefore data on cross-border transactions (especially for FOB valuation) can be used.

Figure 3.8 Mirror transactions to cases b and d – two countries involved ('postponed export')

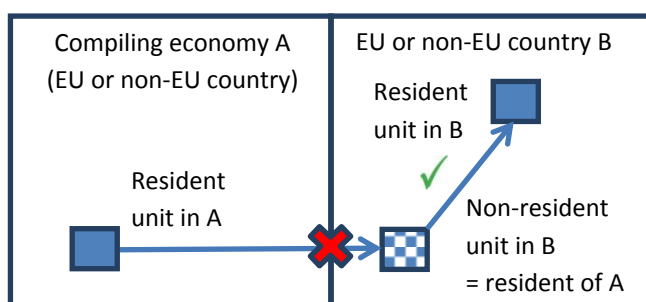

33. Referring to section 3.3, case (c) and section 3.4, case (e): A resident of a compiling economy (A) is registered for VAT in Member State B (see figure 3.9). If this unit purchases goods in Member State B and imports these goods into the compiling economy, from a theoretical point of view, the import should be the purchase in economy B. However, also other costs may be added to the value of goods on its way to country A, so at least for imports in CIF valuation the data on cross-border movements can be used. Data on purchases are not easily accessible.

Figure 3.9 Mirror transactions to cases c and e – two countries involved ('advanced imports')

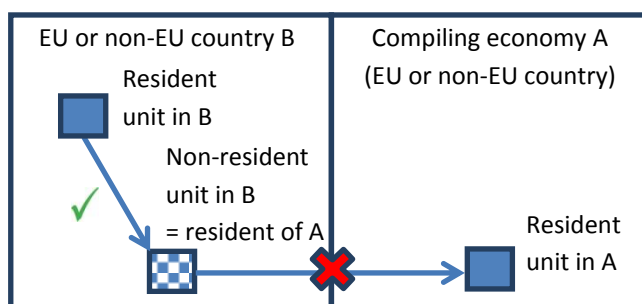

Please note: In the examples in figures 3.8 and 3.9 the unit which reports all cross-border transactions in all Member States (i.e. into Intrastat in each Member State) is a resident of country A. It is this one unit reporting transactions on both sides of the borders (e.g. reporting exports from country B and imports to country C) even though there is a different VAT number of the unit in each Member State.

34. Referring to section 3.4, case (f): A resident of a compiling economy is registered for VAT in Member State B (see figure 3.10). If this unit purchases goods from a resident unit of this Member State B and subsequently sells them to another resident unit of Member State B, this is classified as **merchandising**. For the compiling economy, in NA/BoP, the **purchase** should be registered as a **negative export** and the **sales** of the goods to another resident unit of Member State B should be registered as a **positive export**. These transactions (in the compiling economy) are usually covered by the data sources focused on merchandising transactions.

Figure 3.10 Mirror transactions to case f – inverse merchandising, two countries involved

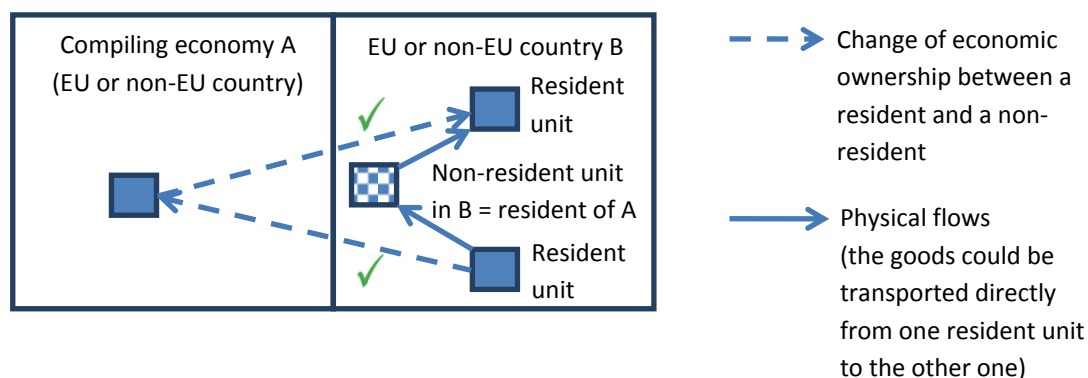

Annex A Composition of the Expert Group:

<u>Delegate name</u>	<u>Administration</u>	<u>Country</u>
Tereza Košťáková	Czech Statistical Office	Czech Republic
Liane Ritter	DESTATIS	Germany
Éanna O'Connor	CSO	Ireland
Joseph Vella	Statistics Malta	Malta
Stephen Chong	Statistics Netherlands	the Netherlands
Willem de Jong	Statistics Netherlands	the Netherlands
Erwin Kolleritsch	Statistics Austria	Austria
Jaroslav Dolinič	Statistical Office of the SR	Slovak Republic
Henk Nijmeijer	Eurostat (Unit C.1, chair)	
Jens Gruetz	Eurostat (Unit C.1)	
Alzbeta Ridzonova	Eurostat (Unit G.5)	
Karo Nuortila	Eurostat (Unit G.5)	
Matthias Ludwig	Eurostat (Unit C.2)	
Isabelle Rémond-Tiedrez	Eurostat (Unit C.2)	

Annex B Numerical examples

Numerical example 1

A resident of country B (B1) is registered for VAT in country A. This unit shifts goods for 1000 euro from country B to country A. A resident of country A (A1) stores the goods in its warehouse. The rental fee is 50 euro. Later the non-resident B1 sells the goods to a resident of country A (A2) for 1300 euro.

Figure AB1 Numerical example 1

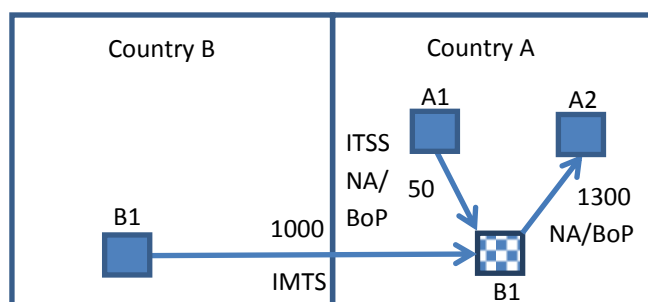

Table AB1 Numerical example 1

	Country B		Country A	
	IMTS/ITSS	NA/BoP	IMTS/ITSS	NA/BoP
Exports total	1 000	1 300	50	50
Exports of goods	1 000	1 300		
Exports of services			50	50
Imports total	50	50	1 000	1 300
Imports of goods			1 000	1 300
Imports of services	50	50		
Balance (exports minus imports)	950	1 250	-950	-1 250
Goods	1 000	1 300	-1 000	-1 300
Services	-50	-50	50	50

Numerical example 2

A resident of country B (B1) is registered for VAT in country A. This unit shifts goods for 2000 euro from country B to country A. A resident of country A (A1) stores the goods in its warehouse. The rental fee is 100 euro. Later the non-resident B1 sells the goods to a resident of country A (A2) for 1300 euro and for 5000 to a resident unit of country C (C1).

Figure AB2 Numerical example 2

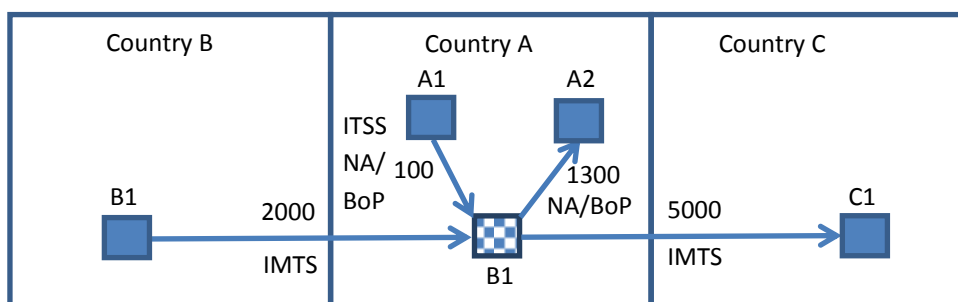

Table AB2 Numerical example 2

	Country B		Country A		Country C	
	IMTS/ITSS	NA/BoP	IMTS/ITSS	NA/BoP	IMTS/ITSS	NA/BoP
Exports total	2 000	6 300	5 100	100		
Exports of goods	2 000	6 300	5 000			
Exports of services			100	100		
Imports total	100	100	2 000	1 300	5 000	5 000
Imports of goods			2 000	1 300	5 000	5 000
Imports of services	100	100				
Balance (exp. minus imp.)	1 900	6 200	3 100	-1 200	-5 000	-5 000
Goods	2 000	6 300	3 000	-1 300	-5 000	-5 000
Services	-100	-100	100	100		

Annex C Useful sources

Balance of Payments and International Investment Position BPM6

<http://www.imf.org/external/pubs/ft/bop/2007/bopman6.htm>

European System of Accounts 2010

<http://ec.europa.eu/eurostat/web/products-manuals-and-guidelines/-/KS-02-13-269>

EORI number verification

http://ec.europa.eu/taxation_customs/dds2/eos/eori_validation.jsp?Lang=en&Screen=0&oriNumb=&Expand=false

Foreign Trade in Czech National Accounts – Methodology Guide according to ESA 2010 (up-dated version, April 2014)

<http://apl.czso.cz/pll/rocenka/b1.metodika?mylang=EN>

Guide to measuring global production (prepared by the Task Force on Global Production, draft)

http://unstats.un.org/unsd/nationalaccount/consultationDocs/GuideMGP_CES_Consultations.pdf

IMTS Compiler’s Guide (EU from page 113)

<http://unstats.un.org/unsd/statcom/doc12/BG-IMTS2010-CM.pdf>

ITGS User Guide

<http://ec.europa.eu/eurostat/en/web/products-manuals-and-guidelines/-/KS-GQ-14-014>

Manual on goods sent abroad for processing

<http://ec.europa.eu/eurostat/web/products-manuals-and-guidelines/-/KS-GQ-14-003>

Summary on VAT system in the EU

http://europa.eu/legislation_summaries/taxation/l31057_en.htm

http://ec.europa.eu/taxation_customs/taxation/vat/how_vat_works/index_en.htm

The Impact of globalization on national accounts (UNECE/EUROSTAT/OECD)

http://www.unece.org/fileadmin/DAM/stats/groups/wggna/Guide_on_Impact_of_globalization_on_national_accounts_FINAL21122011.pdf

Vademecum on VAT obligations

http://ec.europa.eu/taxation_customs/taxation/vat/traders/vat_community/index_en.htm

VIES - VAT number verification

http://ec.europa.eu/taxation_customs/vies/?locale=en

Annex D Definitions/explanations

According to ESA 2010/BPM6, unless indicated otherwise.

Imports/exports

Imports of goods and services consist of transactions in goods and services (purchases, barter, and gifts) from non-residents to residents.

Exports of goods and services consist of transactions in goods and services (sales, barter, and gifts) from residents to non-residents.

Imports and exports of goods occur when economic ownership of goods changes between residents and non-residents. This applies irrespective of corresponding physical movements of goods across frontiers.

Arrivals/dispatches vs. intra-EU acquisitions/supplies [according to VAT Council Directive³⁰]

Arrival means a movement of goods initially dispatched from another Member State entering the Member State of arrival, which are either Community goods except goods which are in simple circulation between Member States or goods maintained under the inward processing customs procedure or the processing under customs control moving between Member States.

If a taxable person in Member State of arrival, i.e. in Member State other than that in which dispatch or transport of the goods began, acquires the right to dispose as owner of the goods dispatched or transported to that person, by or on behalf of the vendor or that person, the person will declare intra-EU acquisition on VAT return.

Dispatch means a movement of goods leaving the Member State of dispatch for a destination in another Member State, which are Community goods, except goods which are in simple circulation between Member States or goods maintained under the inward processing customs procedure or the processing under customs control moving between Member States.

If a taxable person in Member State of dispatch, supplies goods dispatched or transported to a destination outside their respective territory but within the Community, by or on behalf of the vendor or the person acquiring the goods, for another taxable person, or for a non-taxable legal person acting as such in a Member State other than that in which dispatch or transport of the goods began, then the person may exempt such supply from VAT; the taxable person will declare intra-EU supply on VAT return.

If a taxable person dispatches or transports goods or dispatch or transports is carried out on his behalf for the purposes of his business, to a destination outside the territory of the Member State in which the goods is located then such transaction is considered the intra-EU supply of goods. Then this taxable person as owner of goods which are physically brought into the reporting economy from another EU Member State might be required to register for VAT and declare intra-EU acquisition in that Member State.

³⁰ Council Directive No 2006/112/EC of 28 November 2006 on the common system of value added tax

Transit trade

Transit trade is where goods cross a country on their way to their final destination, and, for the country crossed, are generally excluded from foreign trade statistics, balance of payments statistics and the national accounts.

Quasi-transit trade

Quasi-transit trade are goods imported into a country, cleared through customs for free circulation within the EU, and then dispatched to a third country in the EU. The entity used for customs clearance is usually not an institutional unit as defined in ESA 2010, Chapter 2, and so does not acquire ownership of the goods. In this case, the import is shown in the national accounts as a direct import to the final destination, as in the case of simple transit trade. The appropriate value is that recorded as the goods enter the final destination country.

Quasi-transit trade may occur also on export. The goods exported from a Member State to a non-member country may be cleared for exports in another Member State (usually in the Member State of exit, where the goods leave the customs territory of the EU).

The text above concerns the 'narrow' definition of quasi-transit trade (only from/to non-EU). See also footnote 7 on page 6.

Merchandising

Merchandising is defined as the purchase of goods by a resident (of the compiling economy) from a non-resident combined with the subsequent resale of the same goods to another non-resident without the goods being present in the compiling economy. Merchandising occurs for transactions involving goods where physical possession of the goods by the owner is unnecessary for the process to occur. The treatment of merchandising is that:

- a. the acquisition of goods by merchants is shown under goods as a *negative* export of the economy of the merchant;
- b. the sale of goods is shown under goods sold under merchandising as a positive export of the economy of the merchant;
- c. the difference between sales over purchases of goods for merchandising is shown as the item 'net exports of goods under merchandising'. This item includes merchants' margins, holding gains and losses, and changes in inventories of goods under merchandising. As a result of losses or increases in inventories, net exports of goods under merchandising may be negative in some cases; and
- d. Merchandising entries are valued at transaction prices as agreed by the parties, not FOB.

Inverse merchandising

Inverse merchandising is defined as the purchase of goods by a non-resident from a resident (of the compiling economy) combined with the subsequent resale of the same goods to another resident (of the compiling economy) without the goods leaving the compiling economy. The inverse merchandising is not explicitly defined in ESA 2010. Strictly according to ESA 2010 (par. 18.41) and BPM6 (par. 10.45) rules, these purchases and sales should be included under general merchandise. But they may be recorded analogously to merchandising (on import side). Whether the practice should deviate from ESA 2010/BPM6 has to be discussed further. A new treatment of 'inverse merchandising' may be considered in BPM7 and the next SNA and ESA. If the compilers are able to distinguish these sales/purchases by non-residents with goods not crossing the borders from sales/purchases related

to goods crossing the borders then these transactions may be recorded as inverse merchanting. The proposed treatment would be:

- a. the acquisition of goods by non-resident is shown under goods as a *negative* import of the compiling economy;
- b. the sale of goods by non-resident is shown as positive imports of the compiling economy;
- c. the difference between sales over purchases of goods for merchanting is shown as the item 'net imports of goods under inverse merchanting'.

If such a distinction in primary data sources is not possible, these sales and purchases should be recorded as export and import of goods along with all other domestic sales/purchases by non-residents with residents.

Goods for processing

Imports and exports occur when there is a change of ownership between residents and non-residents. Physical movement of goods across national borders does not by itself imply an import or export of these goods. Goods sent abroad for processing (without a change of ownership between residents and non-residents) are not recorded as exports and imports.

The 2008 SNA, the BPM6 and the ESA 2010 do not impute a change of ownership, but rather show only one entry — an import of the processing service. This would be an export of the service for the country in which the processing takes place. This recording is more consistent with the institutional records and associated financial transactions. It does, however, cause an inconsistency with the International Merchandise Trade Statistics (IMTS). The IMTS continue to show the gross value of the exports for process and returning imported processed goods.

Re-exports

Re-exports are foreign goods (goods produced in other economies and previously imported with a change of economic ownership) that are exported with no substantial transformation from the state in which they were previously imported. Given that re-exported goods are not produced in the economy concerned, they have less connection to the economy than other exports. The difference between re-exports and quasi-transit trade is that in case of re-exports the owners of the goods are residents (of the compiling economy whose territory the goods are crossing on its way to final customers), whereas in case of quasi-transit trade the owners are non-residents (in the compiling economy whose territory the goods are crossing on its way to final customers).