

## **CORRESPONDENTS' GUIDELINES No 11**

### **Subject: Specification of a data model for the electronic data interchange under Regulation (EC) No 1013/2006 on shipments of waste**

1. These correspondents' guidelines represent the common understanding of all Member States on how Regulation (EC) No 1013/2006 on shipments of waste (Waste Shipment Regulation – WSR) should be interpreted. The guidelines were agreed by the correspondents through written procedure on 19 July 2019. They are not legally binding. The binding interpretation of European Union law is an exclusive competence of the Court of Justice of the European Union (CJEU). The guidelines apply from 20 July 2019 and should be reviewed at the latest five years from the above date and, if necessary, revised.

#### **1. Introduction**

2. These correspondents' guidelines provide information for:

- (a) Persons and parties involved in the procedure of prior written notification and consent according to the WSR, such as notifiers, waste producers, collectors, dealers, brokers, holders, consignees, waste carriers and recovery or disposal facilities, and
- (b) Authorities responsible for the enforcement of the WSR

in cases where the competent authorities concerned and the notifier agree to exchange information and documents by means of electronic data interchange in accordance with the first subparagraph of Article 26(4) of the WSR.

3. In addition, these correspondents' guidelines provide information for:

- (b) Persons and parties involved in the general information requirements according to Article 18 of the WSR, such as persons arranging shipments, waste producers, collectors, dealers, brokers, waste carriers, consignees, recovery facilities and laboratories, and
- (b) Authorities responsible for the enforcement of the WSR

in cases where the competent authorities concerned accept the exchange of information and documents by means of electronic data interchange.

#### **2. Data model for the electronic data interchange**

##### **2.1 Data model for the procedure of prior written notification and consent**

4. *There is a need for guidance on a data model for the electronic data interchange of information and documents listed in Article 26(1) to the WSR.* A Union-wide approach is needed in order to ensure that the information and documents listed in Article 26(1) can be exchanged by electronic data interchange using the same data model.

5. *As a common understanding of the correspondents,* it has been agreed that the data model provided in the specification contained in the Appendix to these guidelines should be used for the electronic data interchange of the information and documents listed in Article 26(1).

## **2.2 Data model for the general information requirements**

6. *There is a need for guidance on a data model for the electronic data interchange of information and documents under Article 18 of the WSR.* A Union-wide approach is needed in order to ensure that the information and documents under Article 18 can be exchanged by electronic data interchange using the same data model.

7. *As a common understanding of the correspondents,* it has been agreed that the data model provided in the specification contained in the Appendix to these guidelines should be used for the electronic data interchange of the information and documents under Article 18 of the WSR.

## Specification of a data model

### Contents

A. Requirements.....	3
B. Content.....	5
C. Conventions.....	7
D. Basics.....	7
I. Definitions .....	7
II. Structure of the XML documents .....	8
E. XML Schema .....	10
I. Basics .....	10
II. Overview of XML Schema Definition files and the target namespaces .....	11
1. basetypes.xsd .....	11
2. message.xsd.....	11
3. notification.xsd.....	12
4. wastemovement.xsd .....	12
5. annex7.xsd.....	12
6. statement.xsd.....	12
7. codelists.xsd .....	12
F. Structure .....	13
I. General .....	13
II. Messages .....	13
1. MessageID .....	13
2. DocumentID.....	13
3. OperationID .....	13
4. ReferToID.....	13
6. SpecificationVersion .....	14
7. CreationDateTime .....	14
8. Vendor .....	14
9. BinaryAttachments.....	15
10. AnyXml.....	18

11. Communication .....	19
12. Correction and cancellation .....	19
13. Seals and Signatures.....	20
14. Internationalization .....	20
G. Document.....	22
I. Completeness .....	22
II. Parties.....	22
III. Person.....	23
IV. NotificationDocument.....	23
1. Submission.....	23
2. Acknowledgement.....	25
3. Decision .....	25
V. Movement document .....	26
1. TransportAnnouncement .....	26
2. Additional information .....	27
3. CertificateOfWasteReceipt.....	27
4. CertificateOfCompletion .....	27
5. CustomsOffice .....	27
VI. Annex VII .....	27
1. TransportAnnouncement .....	28
2. CertificateOfWasteReceipt.....	29
VII. Statement Document.....	29
H. Processing of messages.....	30
I. General .....	30
II. Notification procedure .....	30
1. Preparation of a notification for submission to a competent authority (new operation).....	30
2. Acknowledgement (follow-up to a submission).....	30
3. Decision / Consent.....	31
4. Creation of a Movement Document (transport announcement) for an existing notification ..	31
5. Conduct of the transport.....	32
6. Receipt of waste (CertificateOfWasteReceipt).....	33
7. Disposal/recovery of waste (CertificateOfCompletion) .....	33
III. General information requirements (Art. 18/ Annex VII).....	33
1. Annex VII Announcement.....	33
2. Conduct of the transport.....	34

3. Receipt at the consignee or facility/laboratory.....	34
IV. Exceptions from the rule.....	34
1. A transport arrives at the facility, the preceding messages are missing.....	34
2. Other types of interchange.....	35
I. Code lists.....	36
J. Specific use case.....	37
I. Notification IT -> AT -> DE.....	37
1. Remarks.....	37
II. Movement document IT -> AT -> DE.....	37
III. Annex VII.....	38
IV. Statement.....	39
1. Case: Subsequent claim.....	39
2. Case: Correction.....	40
K. Electronic seals/signatures.....	41
I. Technical aspects.....	41
1. General.....	41
2. Creating electronic seals/signatures.....	41
II. Example of a seal or signature.....	42
III. Seal and signature coverage.....	42
Annex 1: Conceptual Data Model.....	43
Annex 2: Schema Structure and Description.....	88

## A. Requirements

The specification defines the format for electronic data exchange in the area of shipments of waste.

The data exchange format takes all blocks of the documents contained in Annex IA, Annex IB and Annex VII into account. It also contains a common message (statement) for the exchange of further information.

Processes comprising electronic data interchange (EDI; exchange of structured electronic data) and other types of interchange (e.g. paper, fax, PDF) will be supported. In the EDI annexes to documents such as Annex IA are supported as arbitrary binary attachments, for example as PDF.

This requirement takes the migration process into account, which will lead from other types of interchange to EDI. While this process is on-going, either data is converted to structured electronic form or documents are missing in the EDI.

Additional information with respect to the fields in the documents was added to support the electronic processing of data. For instance, a structured address block, containing elements such as post code, city name and street name, and complying with UN/CEFACT standards is used in the XML Schema Definition.

The requirements for field dimension and types were acquired by the Member States.

To streamline the development of the process, the requirements were reduced to a necessary minimum.

The provisions at the EU<sup>1</sup>, OECD and Basel levels are respected.

---

<sup>1</sup> Consolidated versions of the Waste Shipment Regulation are available at <http://eur-lex.europa.eu/legal-content/EN/TXT/?qid=1523292263903&uri=CELEX:02006R1013-20180101>

## B. Content

This document is part of a package which describes the XML electronic exchange format. The specification describes the overall structure and the correct application of the exchange format.

The foundation of the data model is the XML Schema Definition (XSD), which defines and describes the actual structure of XML instance documents for the Annexes IA, IB and VII and related information in detail. There are the following XSD files that are available at the website of the European Commission<sup>2</sup>:

- notification.xsd
- wastemovement.xsd
- annex7.xsd
- basetypes.xsd
- codelists.xsd
- message.xsd
- statement.xsd

The XSD files are human readable but it is not practical to do so. Instead, specialized tools are needed to digest the structures and definitions contained in these files.

To compensate this shortcoming, the specification document contains two annexes, generated from the XSD to provide a digestible representation. The generation of the annexes from the XSD also guarantees consistency of the provided information in case of modifications of the XSD.

Annex 1 contains a Conceptual Data Model, which contains the contents of the Annexes IA, IB and VII, the blocks and fields according to the order of these Annexes. The columns Type, Data type length, Data Element Name and Description (columns 5 to 8) have been extracted from the XSD corresponding to the fields described in columns 1 to 4. An additional column Reference (column 9) establishes the connection to annex 2 (see below), the Schema Structure and Description, to provide further information.

Annex 2 contains the Schema Structure and Description which represents the hierarchical structure of the XSD. The XSD basically define types containing elements building the actual XML data instances being exchanged between the parties. These types can be reused to minimize redundancy, which also reduces implementation efforts. Annex 2 provides two lists of types sorted alphabetically, a list of complex content types and a list of simple content types; the complex content types are the key types for understanding the XSD. There exist links between different types which are provided for easy navigation.

For explanation, the following examples of XML files, which show the development of the messages for every document type (Annex IA, Annex IB and Annex VII and related information) throughout the workflow are available at the website of the European Commission<sup>3</sup>:

- nf\_submission.xml
- nf\_acknowledgment.xml

---

<sup>2</sup> See compressed file linked to Correspondents' Guidelines No 11 on <https://ec.europa.eu/environment/waste/shipments/guidance.htm>

<sup>3</sup> *Ibid.*

- o nf\_decision\_at.xml
- o nf\_decision\_de.xml
- o nf\_decision\_it.xml
- o wm\_announcement.xml
- o wm\_transport1.xml
- o wm\_transport2.xml
- o wm\_receipt.xml
- o wm\_completion.xml
- o a7\_announcement.xml
- o a7\_transport1.xml
- o a7\_transport2.xml
- o a7\_receipt.xml
- o a7\_transport1\_correction.xml
- o nf\_submission\_cancelled.xml
- o statement\_inform.xml
- o statement\_request.xml
- o statement\_response.xml
- o nf\_submission\_incorrect.xml
- o statement\_request\_correction.xml
- o nf\_submission\_corrected.xml

A section in the specification describes the steps in detail and references the specific XML file they apply to. The notification example files (beginning with nf) contain digital signatures for demonstration purposes only. The signatures are not valid. They only show how a signed document would look like.

In addition, examples-printouts that contain a corresponding pdf file for every xml file representing an Annex IA, IB or VII and a separate example for an electronic seal or signature (*signature.xml*) are available at the website of the European Commission<sup>4</sup>.

---

<sup>4</sup> *Ibid.*



## C. Conventions

The names of XML elements are italicized.

This specification uses the key words (MUST, SHALL, etc.) of RFC 2119<sup>5</sup> to indicate the requirement levels.

## D. Basics

### I. Definitions

XML Version 1.0<sup>6</sup> is used for the data exchange format.

The XSD adheres to XML schema 1.0<sup>7</sup>.

The exchanged data instances (XML files) are called *messages*.

Every message used for the interchange of data covered by Annexes IA, IB and VII contains the whole range of information from that respective Annex. For example, in the message confirming waste receipt, previously exchanged information, such as transport announcement and information provided by carriers, must be contained. The completeness of the document is important for legal reasons.

The purpose of an *operation* is to keep related documents together. In a notification process, all messages and their annexes relating to one specific notification belong to one operation. With general information requirements according to Article 18, all messages and their annexes relating to one contract belong to one operation.

Figure 1 illustrates the relationship between operations, documents and messages.

---

<sup>5</sup> <https://www.ietf.org/rfc/rfc2119.txt>

<sup>6</sup> Extensible Markup Language (XML) 1.0 (Fifth Edition) <https://www.w3.org/TR/xml>

<sup>7</sup> XML Schema 1.1 is not used as the availability of Schema 1.1 compliant open source XML parsers is limited (e.g. for C++ only Apache Xerces-C is available but only 1.0 compliant).

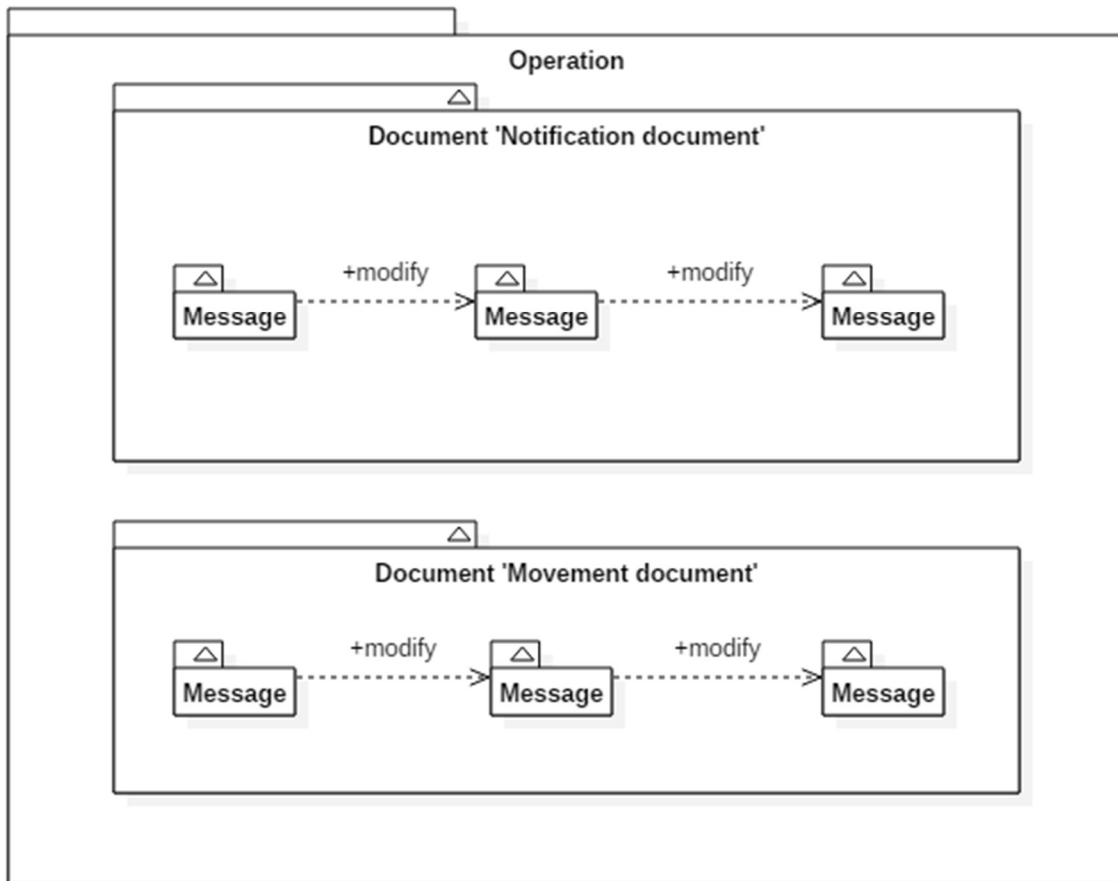

Figure 1 Relationship between operations, documents and messages

Each message used for the interchange of data covered by Annexes IA, IB and VII is a follow up of another message, with exception of the first one. The messages build up a chain in which each message refers to the preceding one. In some use cases several preceding messages may exist (e.g. multiple consents of a notification). Every message contributes a portion to the final document. A subsequent message must contain all information of the preceding message. It must not change or omit any information.

The contents of the documents / messages relating to Annex IA and IB must adhere to the provisions of Annex IC<sup>8</sup>. The contents of documents / messages relating to Annex VII must adhere to the provisions of Appendix 1 to the Correspondents' guidelines No. 10<sup>9</sup>.

## II. Structure of the XML documents

All documents must start with the following processing instruction:

```
<?xml version="1.0" encoding="UTF-8" standalone="yes" ?>
```

<sup>8</sup> Consolidated versions of the Waste Shipment Regulation are available at <http://eur-lex.europa.eu/legal-content/EN/TXT/?qid=1523292263903&uri=CELEX:02006R1013-20180101>

<sup>9</sup> See [http://ec.europa.eu/environment/waste/shipments/pdf/correspondents\\_guidelines10\\_en.pdf](http://ec.europa.eu/environment/waste/shipments/pdf/correspondents_guidelines10_en.pdf)

The encoding must be UTF-8. In comparison with other encodings (e.g. UTF-16) it is space efficient and if electronic signatures should be applied, there is no need to transcode the document which is computationally efficient.

The documents must not use Byte Order Mark (BOM).

The processing instruction must define standalone="yes" to indicate that no external data is needed to process the document.

All namespace definitions must be located in the root element of the XML instance. Default namespace definitions within the document must not be used. The correct implementation of default namespaces is challenging and errors in this field lead to accidentally broken electronic signatures.

## E. XML Schema

### I. Basics

The data exchange format is defined by XML Schema 1.0 Definition<sup>10</sup>. It defines the structure and the constraints applying to the contents of the data to exchange. All elements are bound to namespaces. The *elementFormDefault*= "qualified" attribute is set in the root element of the XML Schema Definition. *attributeFormDefault* is set to "unqualified".

The consequences for XML data instances are that every element without exception must be prefixed with the namespace-prefix consistently.

With regard to declaring data elements as mandatory, or – more generally – with regard to defining the minimum number of occurrences for data elements, the following principle is applied: Via the XML Schema Definition, data elements are declared as mandatory if this is deemed as necessary or recommendable for the technical processing (processability) of data instances. Data elements required according to domain rules, such as by the Waste Shipment Regulation, but not required in the aforementioned technical sense, are not declared mandatory through the XML Schema Definition. The reasoning behind this XML Schema design principle is as follows: The data interchange format is expected to be versatile, not only enabling the interchange of – according to the waste shipment “business rules” – correct and complete data, but also enabling the interchange of incorrect and/or incomplete data.

To keep the XML instance documents small, elements for the sole purpose of grouping fields together were largely omitted. E.g. there is no *carriers* element surrounding the single *carrier* elements.

All attribute names start with a lower case character, element names start with an upper case character.

All names of elements with alphanumeric content used for identification and “look up” purposes end on ID (e.g. PartyID, NotificationID).

The XML Schema Definition defines length restrictions for all simple content elements.

All message content which can be generated by different parties at different points in time is modelled as sub-element under the root element.

---

<sup>10</sup> XML Schema Part 0: Primer Second Edition <https://www.w3.org/TR/XMLschema-0/>

For the following interchange of information according to Article 26 (1) WSR electronic data interchange formats are provided:

notification of a planned shipment pursuant to Articles 4 and 13;	notification.xsd
request for information and documentation pursuant to Articles 4, 7 and 8;	statement.xsd
submission of information and documentation pursuant to Articles 4, 7 and 8;	notification.xsd
written consent to a notified shipment pursuant to Article 9;	notification.xsd
conditions for a shipment pursuant to Article 10;	notification.xsd
objections to a shipment pursuant to Articles 11 and 12;	notification.xsd
information on decisions to issue pre-consents to specific recovery facilities pursuant to Article 14(3);	statement.xsd
written confirmation of receipt of the waste pursuant to Articles 15 and 16;	wastemovement.xsd
certificate for recovery or disposal of the waste pursuant to Articles 15 and 16;	wastemovement.xsd
prior information regarding actual start of the shipment pursuant to Article 16;	wastemovement.xsd
information on changes in the shipment after consent pursuant to Article 17; and	notification.xsd (considered as correction of a notification, see F.II.11)
written consents and movement documents to be sent pursuant to Titles IV, V and VI.	notification.xsd, wastemovement.xsd

## II. Overview of XML Schema Definition files and the target namespaces<sup>11</sup>

### 1. basetypes.xsd

This schema file defines recurring structures and data types. To prevent ambiguous XML documents regarding empty strings vs. omitted elements, the schema defines own types for common string types (token, normalizedString, string), preventing the empty string (minLength=1 facet).

In addition, definitions for recurring structures like address, contact person, declaration and parties are included.

### 2. message.xsd

The message defines a frame containing the actual data of the forms. This frame contains meta information like several IDs for messages and operations, and optional elements like binary attachments and electronic signatures.

---

<sup>11</sup> The filenames, namespaces (in parenthesis) and XML elements (italicized) used throughout the specification use currently a terminology different from the regulation. The filename wastemovement.xsd for example refers to the XML schema file describing the structure of a movement document. Different terminology also used for: Decision (Consent) and CertificateOfDisposal (ConfirmationOfDisposal).

### **3. notification.xsd**

The schema file describes the structure of the notification document (WSR Annex IA). Based on the notification workflow, the notification document consists of parts such as *Submission*, *Acknowledgement* and *Decision*.

### **4. wastemovement.xsd**

The file comprises the definition for the movement document (WSR Annex IB). It consists of parts such as *TransportAnnouncement*, *Transport*, *CertificateOfWasteReceipt* and *CertificateOfDisposal*.

### **5. annex7.xsd**

Whereas WSR Annex IA and Annex IB define information requirements under the “procedure of prior written notification and consent” (WSR Article 3.1), Annex VII defines information requirements under the “general information requirements” (WSR Article 3.2). Due to the similarity of the Annex IB and Annex VII information requirements, the data interchange formats (*wastemovement.xsd* and *annex7.xsd*) are largely similar as well, with many identical or near-identical sub-structures. The main parts are *TransportAnnouncement*, *Transport* and *CertificateOfWasteReceipt*.

### **6. statement.xsd**

This schema file defines a common message called ‘statement’. Its purpose is to exchange common information or to issue requests to the parties in a process. This message is meant to cover all communication needs for which no specific message was designed for.

### **7. codelists.xsd**

In several places codes are used in the forms to provide language independent choice/classification information. The code enumerations are collected in a separate schema file, as changes in code lists may occur independent of changes in data interchange formats. In that case the code list schema definition can be updated without touching other parts of the specification.

## F. Structure

### I. General

In the following sections the meta information, enveloped by the message element, will be described in greater detail. The meta information builds the foundation for actual data of the forms and is important in a technical context.

### II. Messages

The operation can contain multiple documents and multiple messages referencing the same document. To express these relationships three unique IDs have to be defined.

To generate such unique IDs this specification makes use of UUID version 4 based on random numbers as specified in RFC 4122<sup>12</sup> which delivers a great value space ( $2^{122}$ ) making collisions highly improbable.

#### 1. MessageID

Upon creation of a message a new, unique *MessageID* must be created.

#### 2. DocumentID

All messages referring to a distinct document must have the same *DocumentID*. If a new message is created the *DocumentID* from the preceding message must be copied.

#### 3. OperationID

As the name *OperationID* implies, it is equal for all documents and messages belonging to the same operation. The notification and the movement documents must have the same *OperationID*. The *OperationID* keeps different document types together.

#### 4. ReferToID

The purpose of the ReferToID is to reference the message(s) on which another message is based on, i.e. the message(s) from which content is copied into the new message. All messages belonging to a single document form a graph which shows the relationships of the messages to each other. It is possible to follow the evolution of a document from the current message to the first message.

A ReferToID must not refer a message of type statement.

#### 5. ReplyToID

ReplyToID must only be used in the context of the statement message type. Its purpose is to show the sequence of statements interchanged between parties It is possible to have multiple statements as origin of a single response.

---

<sup>12</sup> UUID <https://tools.ietf.org/html/rfc4122#section-4.4>

Figure 2 illustrates the actions which lead to the creation of new IDs.

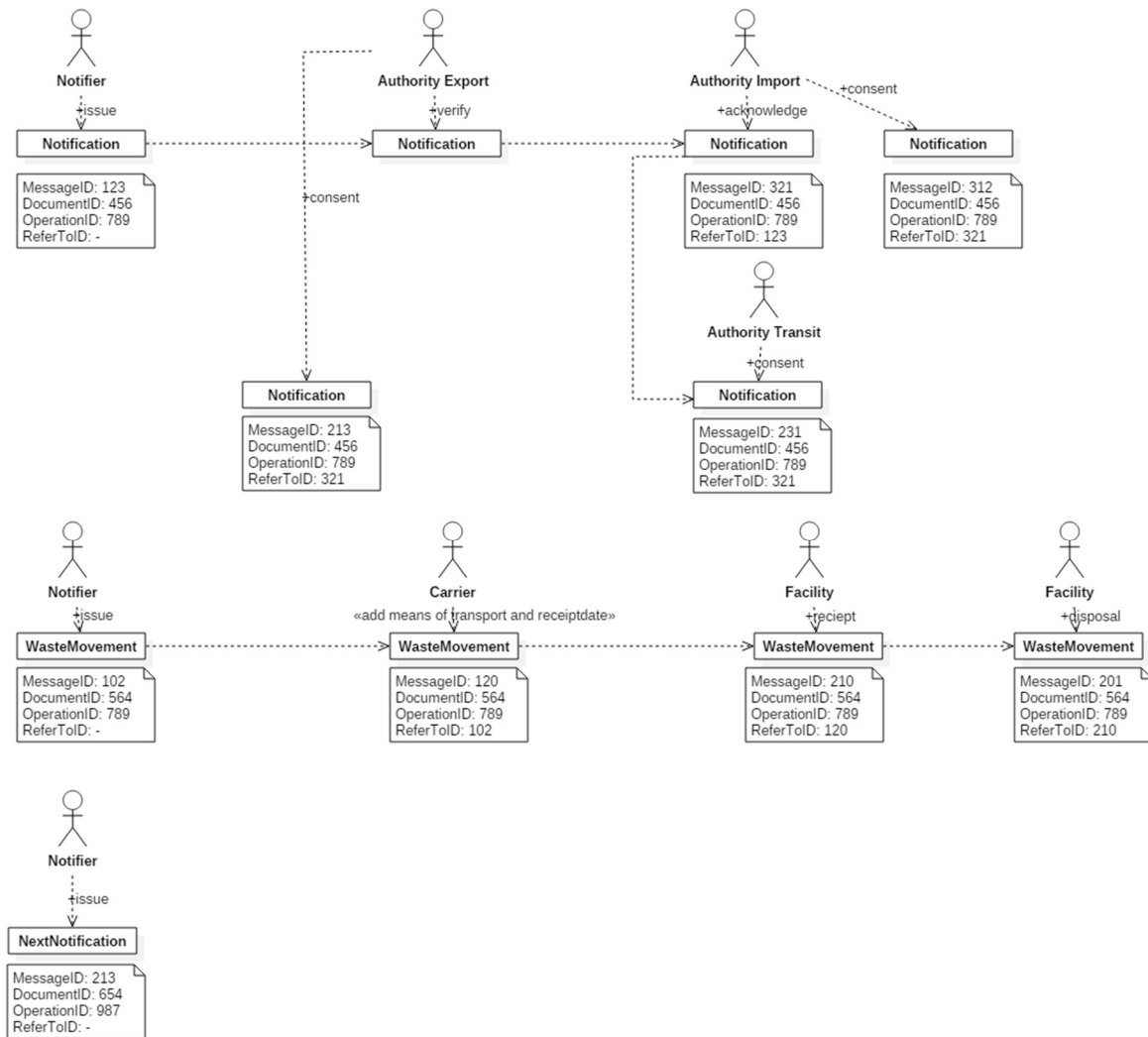

Figure 2: Example of id creation. To prevent a false impression, the IDs are not consecutive numbers. But UUIDs are just too long so random short numbers were used.

## 6. SpecificationVersion

The current version of the specification must be **1.0**. In case of modifications of the exchange format, the *SpecificationVersion* must be changed.

## 7. CreationDateTime

Upon creating a Message a timestamp (timezone 'Z', as in '2018-05-18T16:00:01.7655673Z+02:00') must be created automatically.

## 8. Vendor

It is very likely that a large number of implementations will emerge in the EU. Interoperability will sometimes be a problem, due to different interpretations of the specifications. In case of such incompatibilities, the intention of these elements is to get in contact with the responsible persons fast.

To diagnose incompatibilities in case of different software versions, the vendor structure provides two elements (*ProductID*, *ProductVersion*) to define which product was used and what version of the



product was processing the document. This can accelerate the process of finding the cause for failures.

To provide contact information regarding the vendor of the software the elements EmailURI, WebsiteURI were defined, to record an email address or a website with contact information.

## 9. BinaryAttachments

The element *BinaryAttachment* provides a place for non-structured information like analysis of waste as pdf document.

The *typeID* attribute allows classification of binary attachments, such as for the classification of an annex to the notification and movement document<sup>13</sup> (see Table 1). The *typeID* is defined as an enumeration containing the following values:

Table 1: Classification of binary attachments

<b><i>typeID</i></b>	<b><i>Short</i></b>	<b><i>Long description</i></b>
<i>DealerBrokerContract</i>	Dealer/broker contract	Copy of the contract or evidence of the contract (or a declaration certifying its existence) between the producer, new producer or collector and the broker or dealer (Annex IA block 1 and Annex IC para. 14; Annex III Part 3 point 12)
<i>HandlingRequirements</i>	Handling precautions	Information on special handling precautions, such as those required by producers' handling instructions for employees, health and safety information, including information on dealing with spillage, and instructions in writing for the transport of dangerous goods (Annex IA block 7, Annex IB block 7 and Annex IC paras. 18 and 38)
<i>AgentsDetails</i>	Agent's details and actual carriers	Agent's details and the respective information on actual carriers, where the transport is organised by a forwarding agent (Annex IA block 8 and Annex IC para. 19)
<i>CarrierRegistration</i>	Registration of the carrier(s)	Evidence of registration of the carrier(s) regarding waste transports, e.g. a declaration certifying its existence (Annex

<sup>13</sup> In accordance with Article 4 of the Waste Shipment Regulation, the information and documents listed in Annex II, Parts 1, 2 and 3 must be supplied on or annexed to the notification and movement document; see also Annex IC and the footnotes to the notification and movement documents.

		IA block 8 and Annex IC para. 19) or copy of this registration (Annex II Part 3 point 6)
<i>SiteGenerationProcess</i>	Waste generation process and site	Description of the site and process of waste generation (Annex IA block 9 and Annex IC para. 20)
<i>FacilityPermit</i>	Facility permit	Evidence (e.g. a declaration certifying its existence) of a valid permit according to the Directive 2010/75/EU on industrial emissions in case a facility is located in the EU (Annex IA block 10 and Annex IC para. 21) or copy of the permit (Annex II Part 3 point 2)
<i>TechnologyEmployed</i>	Technology employed	Details on the technology employed for recovery or disposal, if necessary (Annex IA block 11 including footnote 6 and Annex IC para. 22)
<i>RecoveryInformation</i>	Information on certain recovery aspects	If the waste is destined for recovery: information on the planned method of disposal for the non-recoverable fraction after recovery, the amount of recovered material in relation to non-recoverable waste, the estimated value of the recovered material and the cost of recovery and the cost of disposal of the non-recoverable fraction (Annex IA block 11 and Annex IC para. 22)
<i>MotivatedRequest</i>	Duly motivated request	Duly motivated request from the country of dispatch in case of imports into the EU of wastes destined for disposal (Annex IA block 11 and Annex IC para. 22)
<i>WasteComposition</i>	Waste designation and composition	If necessary, commercial name and the names of its major constituents (in terms of quantity and/or hazard) and their relative concentrations (expressed as a percentage), if known, as well as, in the case of a mixture of wastes, the same information for the different fractions and the indication which fractions are destined for recovery (Annex IA block 12 and Annex IC para. 23)

<i>WasteAnalysis</i>	Waste analysis	Chemical analysis of the composition of the waste (Annex IA block 12, Annex IC para. 23 and Annex II Part 3 point 7))
<i>IntendedRoute</i>	Intended route	Information on the intended route between points of exit and entry, including possible alternatives, also in cases of unforeseen circumstances (Annex IA block 15 and Annex IC para. 26)
<i>SpecificConditions</i>	Specific conditions	Specific conditions in relation to a consent, if appropriate (Annex IA block 21 and Annex IC para. 31)
<i>TransportRoutingRoute</i>	Transport routing and route	Information on the routing (point of exit from and entry into each country concerned, including customs offices of entry into and/or exit from and/or export from the Community) and route (route between points of exit and entry), including possible alternatives, also in case of unforeseen circumstances (Annex IB block 16 and Annex IC para. 44)
<i>LiabilityInsurance</i>	Insurance against liability for damage	Evidence of insurance against liability for damage to third parties, e.g. a declaration certifying its existence (Annex II Part 1 point 21) or copy of the policy of this insurance (Annex II Part 3 point 13)
<i>NotificationContract</i>	Notification contract	Evidence of a contract (or a declaration certifying its existence) between the notifier and consignee (Annex II Part 1 point 22) or copy of this contract (Annex II Part 3 point 12)
<i>FinancialGuarantee</i>	Financial guarantee	Evidence of a financial guarantee or equivalent insurance (or a declaration certifying its existence if the competent authority so allows) (Annex II Part 1 point 24), the financial guarantee or equivalent insurance or a copy thereof (Annex II Part 3 point 10), or information concerning the calculation of the financial guarantee or equivalent insurance (Annex II Part 3 point 11)

<i>FacilityAutorisation</i>	Type and duration of the facility authorisation	Type and duration of the authorisation pursuant to which the recovery or disposal facility operates (Annex II Part 3 point 1)
<i>TransportDistance</i>	Transport distances between the notifier and the facility	Transport distance(s) between the notifier and the facility, including possible alternative routes, also in case of unforeseen circumstances and, in the event of intermodal transport, the place where the transfer will take place (Annex II Part 3 point 4)
<i>TransportCost</i>	Costs of transport between the notifier and the facility	Information about costs of transport between the notifier and the facility (Annex II Part 3 point 5)
<i>ProductionProcess</i>	Production process of the waste	Description of the production process of the waste (Annex II Part 3 point 8)
<i>TreatmentProcess</i>	Treatment process for the waste	Description of the treatment process of the facility which receives the waste (Annex II Part 3 point 9)
<i>OtherAnnex</i>	Other annex	Other annexes (e.g. on expected dates or the expected frequency and the estimated quantity of each shipment (blocks 5 and 6, Annex IC para. 17), specific conditions in connection with a consent (Annex IA block 21 and Annex IC para. 31), any other pertinent information for the assessment of the notification in accordance with the Waste Shipment Regulation and national legislation (Annex II Part 3 point 14)
<i>ConsentLetter</i>	Consent letter	Letter for a consent, with or without conditions
<i>Other</i>	Other	Other binary attachment (e.g. cover letter, letter explaining the reasons for an objection (Annex IC para. 31))

## 10. AnyXml

For additional data structures not covered by this specification, the *AnyXml* provides the means to transport these additional data in-band. The included structure must provide a distinct root node, a

namespace URI to prevent name conflicts between different structures and a unique id to identify a specific structure of type URI.

## 11. Communication

To allow bilateral communication between parties a sender can provide a list of recipients together with communication protocol information used for submitting messages to the respective recipients. The *Communication* element contains flexible structures in *ServiceParameter* to support different protocols.

The *ActiveIndicator* contains a Boolean value which defines the actual recipients.

The element *PartyUUID* can optionally reference the party which is the recipient of the message. In case of failure on the communication level, this information can be associated with the party and visualized. For parties not mentioned in the XML but involved in communication the element *RecipientName* can be used to provide information to reference the recipient.

The element *ServiceURI* identifies the type of service (e.g. the protocol or technology).

*ServiceParameter* / *ServiceParameterString* contain information specific to the type of service.

To provide an example for a bilateral communication several parties agreed on, the following XML fragment could define a communication endpoint which uses the REST<sup>14</sup> protocol.

```
<Communication>
  <Active>true</Active>
  <PartyUUID>UUID-of-the-party-reachable-through-this-endpoint</PartyUUID>
  <ServiceURI>REST</ServiceURI>
  <ServiceParameter>
    <Endpoint>http://www.wsr-server.eu</Endpoint>
    <Resource>/documents<Resource>
    <Verb>Post</Verb>
    <ResponseType>JSON</ResponseType>
  </ServiceParameter>
</Communication>
```

*Note: A recommended service parameter structure may be developed and provided as part of the specification at a later point in time. This issue is related to the parameter structure of a message broker addressed under architecture considerations.*

## 12. Correction and cancellation

The elements *CorrectionIndicator* and *CorrectionDescription* must be used for corrections of messages. *CorrectionDescription* may describe the corrections if *CorrectionIndicator* is set to true.

A new *MessageId* must be used for corrections.

See file *a7\_transport1\_correction.xml* for an example of a correction.

If a message is corrected, the correction must contain all contents, i.e. both (a) unchanged and (b) changed or appended contents.

---

<sup>14</sup> [https://en.wikipedia.org/wiki/Representational\\_state\\_transfer](https://en.wikipedia.org/wiki/Representational_state_transfer)

If *CancellationIndicator* is set to true, the whole document - which will probably consist of several messages - will be cancelled. Implicitly all messages belonging to same document are cancelled, too.

If a message is cancelled, the contents with regard to the preceding message must not be changed.

*CancellationDescription* optionally takes a reason for cancellation. Both corrections and cancellations must be created by the party which created the message.

A cancelled message must not be corrected.

See file *nf\_submission\_cancelled.xml* for an example of a cancellation.

### 13. Seals and Signatures

The specification allows for optional electronic seals and/or signatures adhering to the eIDAS regulation of the EU, and thus conforming to XAdES<sup>15</sup> Baseline Signatures B-B. If a signature is mandatory or which kind of electronic signature is demanded is not part of this specification and will be regulated by the competent authorities<sup>16</sup>.

To support applications processing XML instances to relate an electronic signature to a party in the document e.g. for visualization purposes, some kind of information is needed.

The XAdES signature element *ClaimedRole* must be filled with a PartyUUID to specify the block to which the seal or signature belongs.

Qualified certificates for electronic seals allow specification of VAT (value added tax) number, NTR (national trade register) number and identifiers from national schemes. In order to enable a complete verification of seals the same party identifiers must be used in the message as in the certificate.

With regards to the content, the message always gets larger. Subsequent messages include the content of the preceding message and append additional information. In contrast signatures don't contribute to the growth of the document. A specific seal or signature belongs to exactly one message.

Detailed provisions regarding electronic seals and signatures are provided under section K.

### 14. Internationalization

The Annexes provide several places to fill in plain text. The regulation requires to use a language acceptable to the competent authorities concerned. To address this requirement, the *DescriptionType* supports a *languageID* attribute to indicate the language of a text block. The *languageID* conforms to ISO-639-1.

The following elements will be language-aware:

#### a) General

- reason for cancellation

---

<sup>15</sup> <https://www.w3.org/TR/XAdES/>

<sup>16</sup> One option for interoperability between competent authorities requiring seals or signatures by the respective parties (e.g. notifier, consignee) and competent authorities not requiring them can be the provision of seals by competent authorities on behalf of parties.

- reason for correction

#### ***b) Notification***

- (7) other packagetype
- (9) site of generation
- (9) process of generation
- (10) Actual site of disposal / recovery
- (11) additional information to R/D Code
- (11) technology employed
- (11) reason for export
- (12) Designation and composition of waste
- (13) additional information physical characteristics
- (21) specific conditions
- (21) reason for objection of consent

#### ***c) WasteMovement***

- (7) other packagetype
- (9) site of generation
- (10) Actual site of disposal / recovery
- (11) additional information to R/D Code
- (12) Designation and composition of waste
- (13) additional information physical characteristics
- (16) additional information
- (18) additional information to R/D Code

#### ***d) Annex VII***

- (8) additional information to R/D Code
- (9) Designation and composition of waste

#### ***e) Statement***

- statement Text

To demonstrate the usage of the languageID, the xml example file *nf\_submission.xml* contains a site description which is written in Italian and German.

## G. Document

The document is embedded into the message frame. Every message must contain exactly one of the following types of documents:

- Annex IA (Notification document)
- Annex IB (Movement document)
- Annex VII document
- Statement

## I. Completeness

The explanatory value derives from the complete set of messages belonging to the same document (*OperationID* and *DocumentID* is equal for all messages). The *ReferToID* allows the reconstruction of the order of the messages.

## II. Parties

To prevent repetitive definitions for information accompanying the parties in the process, some definitions will be made beforehand.

Every party contains a structure for organization name, person, address and contact information.

Every party holds a list of registration numbers, to identify a party in different countries with different id schemes. The schema also allows other ids (e.g. GLN Global Location Number or VAT identification number). A long term goal would be the definition of a global id scheme to identify parties independently.

For each party and in case of waste producers and facilities for each site, an automatically generated UUID must be assigned to the party.

The UUID has several uses:

- Relating an electronic signature to a party provided within a message. This relationship serves visualisation purposes only (displaying signature related information in the appropriate places in user interfaces and export formats such as PDF) and has no legal relevance. If the PartyUUID would be the same for a party working in different roles, a second ID (e.g. role) would be necessary to uniquely identify the party. The identity of the signatory is known from the certificate.
- External references of information belonging to the party (network transfer status)
- *CertificateOfCompletion* and *CertificateOfWasteReceipt* could possibly be declared by multiple parties.
- Even if Ids like registration numbers are missing, parties in a message can be uniquely (re-) referenced via the *PartyUUID*. This may be particularly relevant with Annex VII documents, which do not require registration numbers.



The following principles apply:

- The same notifier must have different *PartyUUIDs* in different notifications (operations). Vice versa, the same party in different notifications will not have the same UUID, as it is generated independently.
- If a party acts in different roles, for each role a unique *PartyUUID* must be generated.
- In subsequent messages the *PartyUUIDs* will be copied from the previous message. The same Party has the same *PartyUUID* throughout an operation or single notification. This continued use of the same *PartyUUID* is important when aggregating the information from multiple messages to get a consistent data set.
- It is a common procedure to create documents from a template. In case of a notification, the *PartyUUIDs* from the template must not be used in the resulting document, as it would lead to a reuse of the same UUIDs in multiple operations.

### III. Person

A natural person may take part in the processes. The person structure contains the elements to store *GivenName*, *FamilyName* and *GenderCode*.

The *GenderCode* is encoded as described in ISO-5218<sup>17</sup>:

Code	Description
1	male
2	female

If no natural person is given the element *OrganizationName* must be used to name the organization.

### IV. NotificationDocument

Based on the workflow of the notification, it consists of three parts.

#### 1. Submission

The notifier is responsible to provide the information, which corresponds to blocks 1-18. Explanations are provided for some of the blocks.

##### a) Block 3

Single / Multiple Shipment must be derived from the total number of shipments (Block 4).

Recovery / Disposal must be derived from the disposal/recovery operations defined in block 11. It must be taken into consideration that there are several possible situations which use different elements in the XML for the facilities (*NonInterimDisposalRecoveryFacility* or *InitialInterimDisposalRecoveryFacility*)

##### b) Block 5

The element *MassMeasure* contains the weight of the waste. The elements *MinimumMassMeasure* and *MaximumMassMeasure* contain the estimated minimum and maximum weights.

In some countries outside of the EU, the volume (*VolumeMeasure*) may be provided.

---

<sup>17</sup> [https://en.wikipedia.org/wiki/ISO/IEC\\_5218](https://en.wikipedia.org/wiki/ISO/IEC_5218)

Mass measurements must be provided with a *unitCode* attribute set to tonnes (t). Volume measurements must be provided with a *unitCode* attribute set to cubic metres (m3).

### c) Block 7

If none of the codified package types applies (1-8), a textual description of the package type must be provided in the element *PackageDescription*.

### d) Block 8

The data model does not define an upper limit on the number of intended carriers that can be specified within a notification document (*Carrier* element multiplicity of 0..\*). In block 8, there is space for a single intended carrier; a footnote explains: "Attach list if more than one". In case there are two or more intended carriers, provide e.g. "see attached list" in block 8.

The *Carrier* element instances correspond to this as follows:

- A single *Carrier* element instance corresponds to a single carrier named in block 8.
- Two or more *Carrier* element instances correspond to an "attached list", whereby the order of *Carrier* elements in the message is open (e.g. alphabetical order).

Codes for means of transport:

Code	Description
A	Air
R	Road
S	Ship
T	Train
W	Inland waterways

### e) Block 9

The data model does not define an upper limit on the number of waste producers specified within a notification document (*WasteProducer* element multiplicity of 0..\*). In block 9, there is space for a single waste producer; a footnote explains: "Attach list if more than one". In case there are two or more waste producers, provide e.g. "see attached list" in block 9.

The *WasteProducer* element instances correspond to this as follows:

- A single *WasteProducer* element instance corresponds to a single waste producer named in block 9.
- Two or more *WasteProducer* element instances correspond to an "attached list", whereby the order of *WasteProducer* elements in the message is open (e.g. alphabetical order; if appropriate, a new producer could be listed first and the original producers thereafter).

### f) Blocks 10 & 11

To record a facility, two possibilities exist.

If block 10 contains a non-interim facility, the element *NonInterimDisposalRecoveryFacility* must be used (see left side of Figure 3).

If block 10 contains an interim facility, the element *InitialInterimDisposalRecoveryFacility* must be used. Subsequent interim facilities must be recorded in, possibly multiple, *SubsequentInterimDisposalRecoveryFacility* elements. Subsequent non-interim facilities, possibly multiple, must be recorded in *NonInterimDisposalRecoveryFacility* element(s) (see right side of Figure 3).

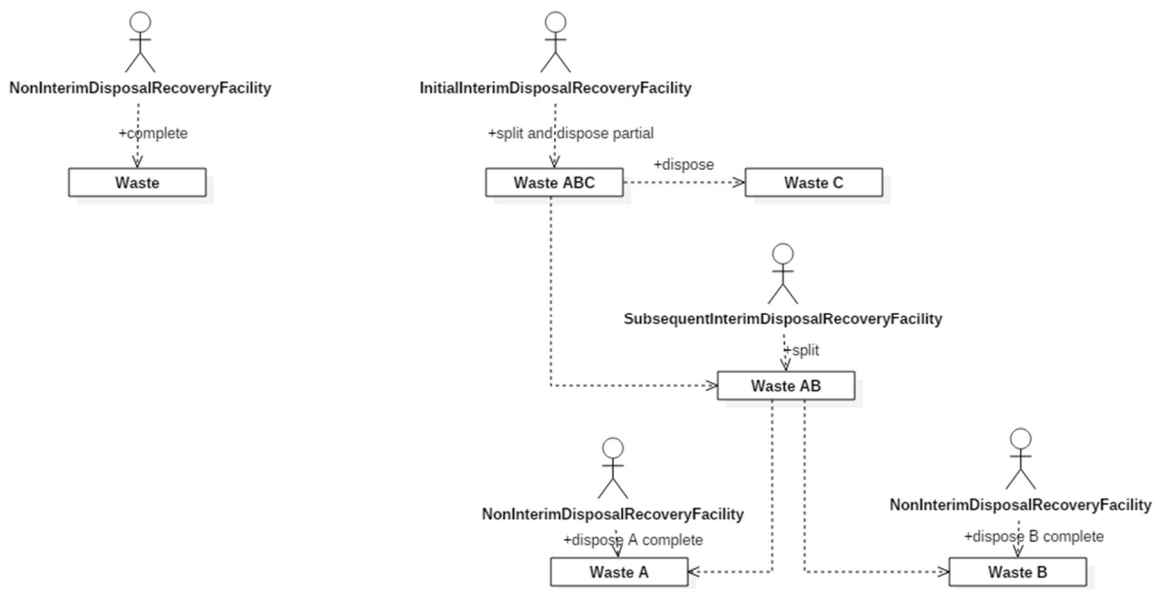

Figure 3 Usage of the different facility structures

### g) Block 13

The block defines the physical characteristics of the waste. Possible codes range from 1 to 6. If no code applies, the element *PhysicalCharacteristicDescription* must be used to describe the characteristics.

### h) Block 14

In case additional information that would facilitate the identification of the waste needs to be provided in relation to block 14(vi), such information can be provided under *WasteDesignationDescription* (block 12).

## 2. Acknowledgement

Refers to block 19 of the document and must be filled by the authority of the import country. In case of exports from the EU or imports into the EU block 19 may be filled by the authority of the transit or export country.

If a code from the list of authorities<sup>18</sup> is applicable, use the element *CompetentAuthorityID*.

## 3. Decision

The decision structure refers to blocks 20-21 of the document. This part of the notification has to be filled in by the competent authorities that provide written consent.

<sup>18</sup> List of Authorities [http://ec.europa.eu/environment/waste/shipments/pdf/list\\_competent\\_authorities.pdf](http://ec.europa.eu/environment/waste/shipments/pdf/list_competent_authorities.pdf)

The electronic exchange format supports the objection of a competent authority. To support this use case, the elements *ConsentGrantedIndicator* and *ObjectionDescription* were specified.

If a code from the list of competent authorities is applicable, use the element *CompetentAuthorityID*.

## V. Movement document

### 1. TransportAnnouncement

The notifier completes the announcement. The announcement corresponds to the blocks 1-16. Explanations are provided for some of the blocks.

#### a) Block 5

The element *MassMeasure* contains the actual weight of the waste. In some countries outside of the EU alternatively the volume (*VolumeMeasure*) may be provided.

Mass measurements must be provided with a *unitCode attribute* set to tonnes (t). Volume measurements must be provided with a *unitCode attribute* set to cubic metres (m3).

#### b) Block 7

In addition to the packaging types provided in the notification document in block 7, the number of packages must be stated.

#### c) Block 8

The element *Carrier* contains the Carriers given in the notification provided by the notifier. The *transport* element will be used in the actual movement. These elements are completed by the carriers assigned to the waste shipment.

The data model does not define an upper limit on the number of carriers specified within a movement document (*Carrier* element multiplicity of 0..\*). In block 8, there is space for up to three carriers in sub-blocks (a), (b) and (c); a footnote explains: "If more than three carriers, attach information as required in blocks 8 (a, b ,c)". In case there are more than three carriers, provide e.g. "see attached list" in block 8.

The *Carrier* element instances correspond to this as follows:

- For up to three *Carrier* element instances, the first, second and third *Carrier* element instances correspond to the first, second and last carrier named in block 8 (a), (b) and (c).
- Four or more *Carrier* element instances correspond to an "attached list", where the order of *Carrier* elements in the message reflects the order of carriers in an attached list.

For means of transport see block 8 of notification in this specification.

#### d) Block 9

The data model does not define an upper limit on the number of waste producers specified within a movement document (*WasteProducer* element multiplicity of 0..\*). In block 9, there is space for a single waste producer; a footnote explains: "Attach list if more than one". In case there are two or more waste producers, provide e.g. "see attached list" in block 9.

The *WasteProducer* element instances correspond to this as follows:

- A single *WasteProducer* element instance corresponds to a single waste producer named in block 9.
- Two or more *WasteProducer* element instances correspond to an “attached list”, whereby the order of *WasteProducer* elements in the message is open (e.g. alphabetical order; if appropriate, a new producer could be listed first and the original producers thereafter).

### **e) Blocks 10 & 11**

The structures from the notification document are also used in the movement document.<sup>19</sup>

### **f) Block 14**

In case additional information that would facilitate the identification of the waste needs to be provided in relation to block 14(vi), such information can be provided under *WasteDesignationDescription* (block 12).

## **2. Additional information**

Block 16 is intended for additional information provided by any person involved in a shipment (notifier or the competent authority of dispatch, as appropriate, consignee, any competent authority, carrier).

The content of block 16 is the union of all contents taken from the messages regarding the block 16 of the document.

## **3. CertificateOfWasteReceipt**

The consignee and the facility confirm the receipt of the waste, corresponding to blocks 17 and 18, respectively.

The element *RejectedIndicator* indicates if the waste was accepted (false) or rejected (true). If no *RejectedIndicator* is present, the waste is accepted.

To indicate partial rejection, the *RejectedIndicator* is set to false and the contents of *RejectedDescription* describe the details of the partial rejection.

## **4. CertificateOfCompletion**

Corresponding to block 19, the facility certifies the completion of the disposal/recovery of the waste received.

It is possible that multiple *CertificateOfCompletion* messages exist, if the waste cannot be disposed / recovered by a single facility.

## **5. CustomsOffice**

Corresponding to blocks 20-22, customs offices are modelled as elements of type party. The main reason is to have a *PartyUUID*. Customs office could sign electronically; to refer to the party, the *PartyUUID* is needed.

## **VI. Annex VII**

The Annex VII document is very similar to the movement document. It seems natural to use the same schema for both documents. While instructions on completing the notification and movement

---

<sup>19</sup> The case of non interim recovery or disposal of wastes according to Article 15 (e) of the regulation is not yet completely considered in this specification.

documents are contained in Annex IC, instructions on completing the Annex VII document are contained in Appendix 1 to the Correspondents' guidelines No 10.

Disadvantages of the approach:

- At first glance the XML documents are indistinguishable
- The more general form could lead to incorrect processing by allowing composition of elements not useful for the current document type

This specification approaches a compromise by specifying Annex VII as a separate document while using the structures of Annex IB, omitting structures not used and adding block 11, which has no equivalent in the movement document.

By using the same structures, code reuse for processing both document types should be obtainable.

The Annex VII document does not contain fields for party registration numbers. By using the structures of the movement document (Annex IB) these numbers are however introduced into the Annex VII XML data format.

## 1. TransportAnnouncement

The announcement corresponds to blocks 1-12 in Annex VII. Explanations are provided for some of the blocks.

### Block 5

See movement document block 8 in this specification.

### Block 6

See movement document block 9 in this specification.

### Block 7

The facility block contains the *RecoveryDisposalFacilityIndicator* which defines if the provided facility is a recovery facility (true) or a laboratory (false). It is not possible to defer the facility type implicitly from the waste operation in the same way as in Annex IB.

In contrast to the movement document only a single facility or a single laboratory must be specified in Annex VII. The element *RecoveryDisposalFacility* is used for this. Independent of the type the common fields for describing a facility must be used.

The elements *SiteDescription*, *TechnologyDescription* and *ReasonForExportDescription* should not be used in the context of Annex VII.

### Block 11

List of countries involved in the shipment. The list consists of the *CountryID* which uses codes from ISO 3166-1 numeric 3. The element *CountryRoleID* contains the role of the country:

Code	Description
I	country of import
E	country of export
T	country of transit

The roles **I** and **E** must be used only once.

## 2. CertificateOfWasteReceipt

The recipient of the waste confirms the receipt of the waste. The document contains a second check box to indicate recovery facility or laboratory. In the XML Schema Definition this second element is omitted because it would be redundant (see block 7).

## VII. Statement Document

The statement document contains optional fields to refer to Annex IA (Element *NotificationID* only) or Annex IB (Element *NotificationID* and *SequenceNumber*) or without a reference by omitting both elements.

Two means of communication are defined for usage with *CategoryType* element: “inform” and “request”.

“Inform” implies an exchange of information where no further action by the receiver is necessary.

A “request” demands a reply by the receiver of the request.

The *TypeCode* element can express the specific purpose of the message. Currently two different type codes are provided:

- request for information and documentation pursuant to Articles 4, 7 and 8
- information on decisions to issue pre-consents to specific recovery facilities pursuant to Article 14(3)

Corresponding to the definitions from UN/CEFACT code list 4037<sup>20</sup> the statement contains a *PriorityCode* element to describe the urgency of a message in three different levels. Other levels defined in code list 4037 were omitted.

Code	Level
1	Immediate
2	Urgent
3	Normal

The *Statement* element finally contains the message text with up to 1024 characters.

In a response as a follow up to a request message the *ReferToID* must contain the *MessageID* of the request. It must also contain the *NotificationID* and/or *SequenceNumber* from the request message and the *TypeCode*. *CategoryCode* normally would change from request to inform.

If a statement is a reply to another statement, the element *ReplyToID* must be used to express the reference between the two statements. The *ReferToID* must be the same from the original statement to keep all statements regarding a specific message together. This mimics the behaviour of threads in email communication.

---

<sup>20</sup> <http://www.unece.org/trade/untdid/d11a/tred/tred4037.htm>

## H. Processing of messages

### I. General

The section specifically describes the existing use cases.

Before submission to competent authorities, completeness and correctness of all data must be ensured. The schema only ensures correctness on a technical level.

Additionally, the elements *CreationDateTime* and *Vendor* must be filled with every creation of a new message.

If a message is created on base of a received message, the complete content of the original message must be copied to the new message. This is illustrated in Figure 4.

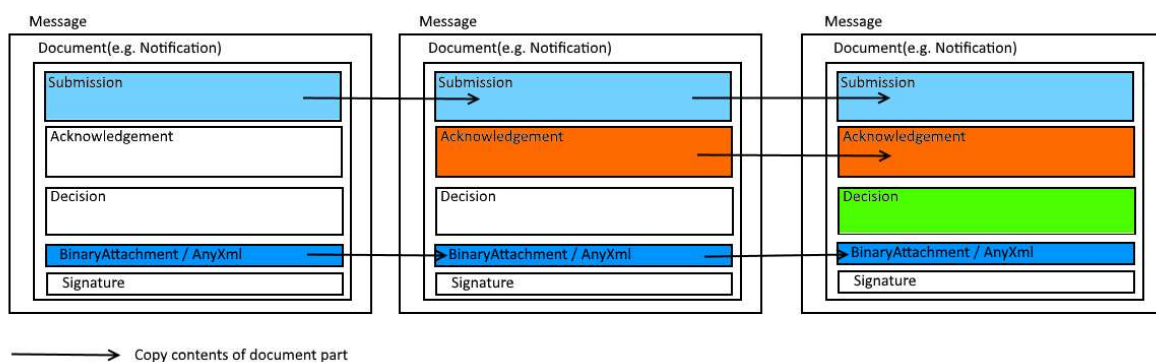

Figure 4 Schematic procedure of data transfer between messages

## II. Notification procedure

### 1. Preparation of a notification for submission to a competent authority (new operation)

All three IDs (*OperationID*, *DocumentID*, *MessageID*) must be newly assigned. The block *NotificationSubmission* of the document must be filled with the appropriate contents.

Additionally, unstructured attachments (*BinaryAttachment*) or structured information that has been agreed on by the involved parties (*AnyXml*) may be added.

A digital signature conforming to the eIDAS regulation, representing a qualified electronic seal or qualified electronic signature, may be applied.

### 2. Acknowledgement (follow-up to a submission)

The confirmation of the receipt of a notification submission by a competent authority leads to a changed document state and therefore is communicated within a new message. The new message contains a new *MessageID*. The process and the document are identical, thus their IDs are kept.

The *ReferToID* is set to the *MessageID* of the *Submission*.

Subsequently, the element *NotificationSubmission* must be included completely in the new message, or it must be completely recreated from a different data source. Within this process, the *PartyUUIDs* identifying the parties are implicitly kept.



The elements *BinaryAttachment* and *AnyXml* are also kept (copied to the new message) and supplemented by additional attachments/extensions if necessary.

*Signature* elements from preceding messages must not be copied to the new message.

A digital signature conforming to the eIDAS regulation, representing a qualified electronic seal or qualified electronic signature, may be applied.

### 3. Decision / Consent

Because multiple competent authorities are usually involved in the notification process, multiple Decision/Consent messages may occur in one operation. *Acknowledgement* and *Decision* may be used multiple times.

Every message gets a new *MessageID*, while *DocumentID* and *OperationID* must be kept. The *ReferToID* refers to the MessageID of the Acknowledgement.

Subsequently, the complete element *NotificationSubmission* and *NotificationAcknowledgement* have to be included completely in the new message, or they must be completely recreated from a different data source.

The elements *BinaryAttachment* and *AnyXml* are also kept and supplemented by additional attachments if necessary.

*Signature* elements from preceding messages must not be copied to the new message.

A digital signature conforming to the eIDAS regulation, representing a qualified electronic seal or qualified electronic signature, may be applied.

If the receipt of a notification submission is not being acknowledged, no Acknowledgement element will be contained in the message. Thus there may be messages including *NotificationDecision* elements, but no *NotificationAcknowledgement* elements. Consent or rejection then implicitly acknowledges the receipt of the notification.

Competent authorities of transit may decide to not send a message containing a *NotificationDecision* and by this provide tacit consent after 30 days. That means that there does not have to be a Decision/Consent message for competent authorities of transit. Thus there may be completed Notification documents not including *NotificationDecision* elements by competent authorities of transit.

### 4. Creation of a Movement Document (transport announcement) for an existing notification

The *OperationID* is kept, as the movement document refers to the same process. *DocumentID* and *MessageID* are newly generated.

When creating the transport announcement, the following XML elements are kept from the notification document:

- *Notifier*
- *Consignee*
- *NotificationNumber*

- *ShipmentQuantity*
- *PackagingTypes* (in addition to taking over packaging information from the notification the amount of packages needs to be added as new data content, see below)
- *Facilities(s)* Block 10 and 11
- *WasteDesignationDescription*
- *PhysicalCharacteristicTypeCode*
- *PhysicalCharacteristicDescription*
- *WasteClassification*

Only the relevant entries of the following elements shall be taken over from the notification document to the movement document (transport announcement), i.e., only those carriers and producers involved in that particular shipment:

- *Carrier* (note: *Transport* is not included)
- *WasteProducer*

The following elements will be incomplete and must be complemented:

- *Packaging*, in contrast to the notification there are fields containing the amount of packages

Finally, the following information having no equivalents in the notification has to be added:

- *SequenceNumber*
- *ActualQuantity*
- *StartDate*
- *DeclarationExporter*
- *DeclarationProducer*
- *AdditionalInformation*

Additionally, unstructured attachments (*BinaryAttachment*) or structured information that has been agreed on by the involved parties (*AnyXml*) may be added.

A digital signature conforming to the eIDAS regulation, representing a qualified electronic seal or qualified electronic signature, may be applied.

No *ReferToID* is included in a transport announcement.

## 5. Conduct of the transport

Every carrier involved creates a new message. The information for the current carrier must be added to the *Transport* structure.

The information includes address and contact data as well as the date of transfer and the means of transport. Optionally, the identification of the vehicles (*VehicleID*) executing the transport may be recorded (license plate, flight number, train number, etc).

*OperationID* and *DocumentID* are copied from the previous message and the *MessageID* must be newly created. The *ReferToID* references the *MessageID* of the previous message (transport announcement message).

A digital signature conforming to the eIDAS regulation, representing a qualified electronic seal or qualified electronic signature, may be applied.

## **6. Receipt of waste (CertificateOfWasteReceipt)**

The reception of waste is communicated by creating a new message (new *MessageID*) using identical *OperationID* and *DocumentID* to the previous message. The *ReferToID* refers to the *MessageID* of the last transport.

All information of the elements *TransportAnnouncement* and *Transport* must be included completely in the new message, or they must be completely recreated from a different data source.

The elements *BinaryAttachment* and *AnyXml* must also be kept.

*Signature* elements of the predecessor document must not be kept.

A digital signature conforming to the eIDAS regulation, representing a qualified electronic seal or qualified electronic signature, may be applied.

## **7. Disposal/recovery of waste (CertificateOfCompletion)**

A new message is created when the facility acknowledges the disposal or recovery, thus a new *MessageID* must be created. The *OperationID* and *DocumentID* stay identical with respect to the previous message. *ReferToID* refers to the *MessageID* of the receipt of waste.

Subsequently all fields of the elements *TransportAnnouncement*, *Transport* and *CertificateOfWasteReceipt* must be copied into the new message or must completely be reproduced from another data source.

The elements *BinaryAttachment* and *AnyXml* must also be kept.

*Signature* elements of the predecessor document must not be kept.

A digital signature conforming to the eIDAS regulation, representing a qualified electronic seal or qualified electronic signature, may be applied.

# **III. General information requirements (Art. 18/ Annex VII)**

## **1. Annex VII Announcement**

The process under the general information requirements (Art. 18/Annex VII) is a process on its own, different from the notification process. The *OperationID* must be used to group transports covered by the same contract.

*MessageID* and *DocumentID* must be created.

The contents of the block *TransportAnnouncement* have to be filled.

Additional unstructured attachments (*BinaryAttachment*) or structured data that has been agreed on between parties may be added.

A digital signature conforming to the eIDAS regulation, representing a qualified electronic seal or qualified electronic signature, may be applied.

## 2. Conduct of the transport

Every carrier involved creates a new message. The information for the current carrier must be added to the *Transport* structure every time.

The information includes address and contact data as well as the date of transfer and the means of transport. Optionally, the identification of the vehicles (*VehicleID*) executing the transport may be recorded (license plate, flight number, train number, etc).

*OperationID* and *DocumentID* are copied from the previous message and the *MessageID* must be newly created. The *ReferToID* references the previous message.

The elements *BinaryAttachment* and *AnyXml* must also be kept.

A digital signature conforming to the eIDAS regulation, representing a qualified electronic seal or qualified electronic signature, may be applied.

## 3. Receipt at the consignee or facility/laboratory

The receipt of waste is communicated by creating a new message (new *MessageID*) using identical *OperationID* and *DocumentID* to the previous message. The *ReferToID* refers to the preceding *MessageID*.

Subsequently, all information of the elements *TransportAnnouncement* and *Transport* must be included completely in the new message, or they must be completely recreated from a different data source.

The elements *BinaryAttachment* and *AnyXml* must also be kept.

*Signature* elements of the predecessor document must not be kept.

A digital signature conforming to the eIDAS regulation, representing a qualified electronic seal or qualified electronic signature, may be applied.

## IV. Exceptions from the rule

This paragraph describes how to proceed when electronic data is not available.

### 1. A transport arrives at the facility, the preceding messages are missing

In principle no processing is possible without a notification number.

#### a) Case 1: No preceding messages are available

A message of type *CertificateOfWasteReceipt* is created. As it is a new document all three IDs are created from scratch. The notification number and the data of the confirmation of receipt is entered accordingly.

If the preceding messages (transport announcement, etc.) are received at a later point in time a new *CertificateOfWasteReceipt* message may be created. To do this the contents of the last message before the *CertificateOfWasteReceipt* and the data of the „provisional“ *CertificateOfWasteReceipt* are copied into the new message, which is then distributed to the same recipients as the “provisional” message.

***b) Case 2: There is a transport announcement, but the transports are missing or incomplete***

All available data is copied. If the missing messages are received at a later point in time a new *CertificateOfWasteReceipt* message may be created. To do this the contents of the last message before the *CertificateOfWasteReceipt* and the data of the „provisional“ *CertificateOfWasteReceipt* are copied into the new message.

**2. Other types of interchange**

If all or some of the contents expected in preceding messages are not available via EDI, then in order to create a new message the data available from types of interchange has to be transferred into structured electronic form and included in that message.

## I. Code lists

Some data is saved in encoded form. Examples are waste codes, package types or physical properties. These codes may be subject to change.

Codes with little potential for change are placed in a separate XML Schema Definition (XSD) file (`codelists.xsd`). This way code lists can be easily replaced with updated versions, without touching other parts of the specification.

In the specification, ISO-3166-1 numeric country codes<sup>21</sup> are used as these are guaranteed to be unique over time, which is not the case for the ISO-3166-1 alpha-2 country codes. However, for notification numbers, ISO-3166-1 alpha-2 country codes are used due to a requirement in Annex IC WSR.

It is noted that software could present information about countries differently than via ISO-3166-1 numeric country codes, e.g. via the ISO-3166-1 two-letter country codes – which is the case in the examples of XML files referred to in section B above. Software could also present information about other data for which codes are used in a different way than via the codes themselves.

Waste lists are not specified within the XML Schema Definition (there are no waste list enumerations), as they are more likely subject to change. This creates flexibility in the case of changes, but also in the choice of the data source the waste list information is obtained from.

In case a waste code for the actual waste is not specified in specific waste list, but must be filled in for legal reasons, the element must have an `xs:nil` attribute set to `true` to indicate that condition.

```
<bt:WasteClassification listID="basel" xs:nil="true"/>
```

The example provides the information, that no code in the *Basel list* is applicable for the current waste. A missing element has a completely different meaning.

---

<sup>21</sup> [https://en.wikipedia.org/wiki/ISO\\_3166-1\\_numeric](https://en.wikipedia.org/wiki/ISO_3166-1_numeric)

## J. Specific use case

### I. Notification IT -> AT -> DE

Figure 5 shows an example of a notification process for a transport from Italy through Austria to Germany. The notifier's head office is located in Italy. He is also the waste producer. At first the blocks 1 to 18 of the notification form are filled in and signed electronically. The first message is created (nf-submission.XML).

The message is sent to the competent authority of IT. The competent authority verifies the notification and sends it to the competent authority of the importing state (DE) without modification, as well as to the competent authority of the transit state (AT).

The competent authority of the import state creates a new message (nf-acknowledgement.XML) by supplementing the received message with the confirmation of receipt. The message is signed and sent to the competent authorities of the exporting and transit states.

Subsequently, all involved competent authorities give their consent. Each competent authority that issues a written consent creates a new message (nf\_decision\_-at|de|it.XML) and sends it to all other authorities and the notifier.

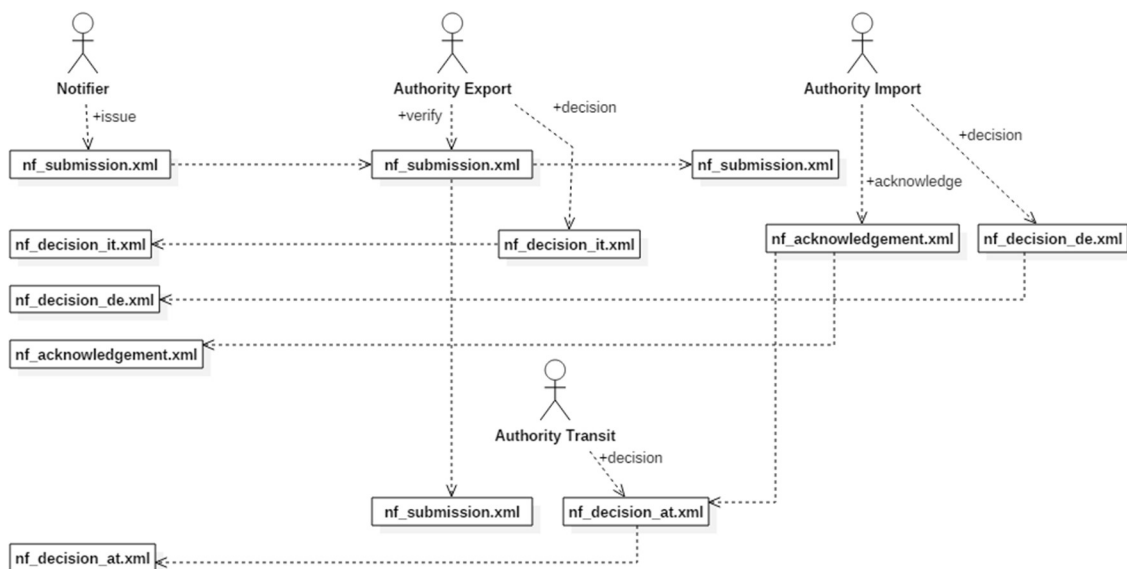

Figure 5 Notification document message creation and flow of messages

#### 1. Remarks

Message exchange between the authorities is not shown in the illustration for the sake of clarity.

The signatures in the example documents are placeholders only and are there for the mere purpose of illustration.

### II. Movement document IT -> AT -> DE

Figure 6 shows an example of the development of a movement document from the transport announcement up to the disposal/recovery at the facility. The notifier creates the waste movement

document from the data of the notification supplemented by any missing data (wm\_announcement.xml).

The first carrier picks up the waste and enters the transfer date and the actual means of transport (wm\_transport1.xml).

The second carrier takes over the waste and enters the transfer date and the actual means of transport (wm\_transport2.xml).

The transport reaches the facility and is accepted (wm\_receipt.xml).

The recovery or disposal is certified (wm\_completion.xml).

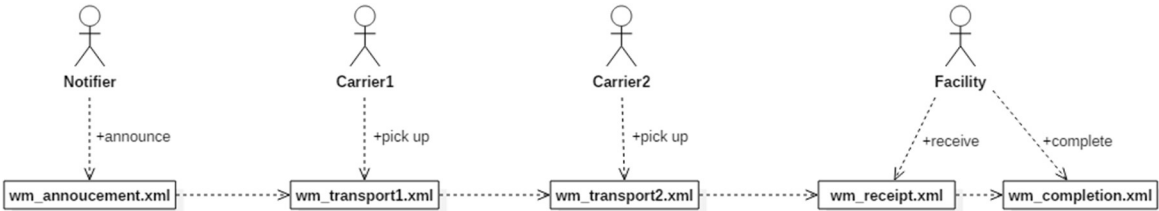

Figure 6 Movement document message creation and flow of messages

### III. Annex VII

The example regarding Annex VII is made analogous to the example of the waste movement document.

The responsible party fills in the *TransportAnnouncement* block (a7\_announcement.xml).

Subsequently the first carrier takes over the waste and creates a new message (a7\_transport1.xml)

The second carrier takes over the waste and the next message is created (a7\_transport2.xml)

The waste is received by the facility which confirms the receipt (a7\_receipt.xml)



## IV. Statement

### 1. Case: Subsequent claim

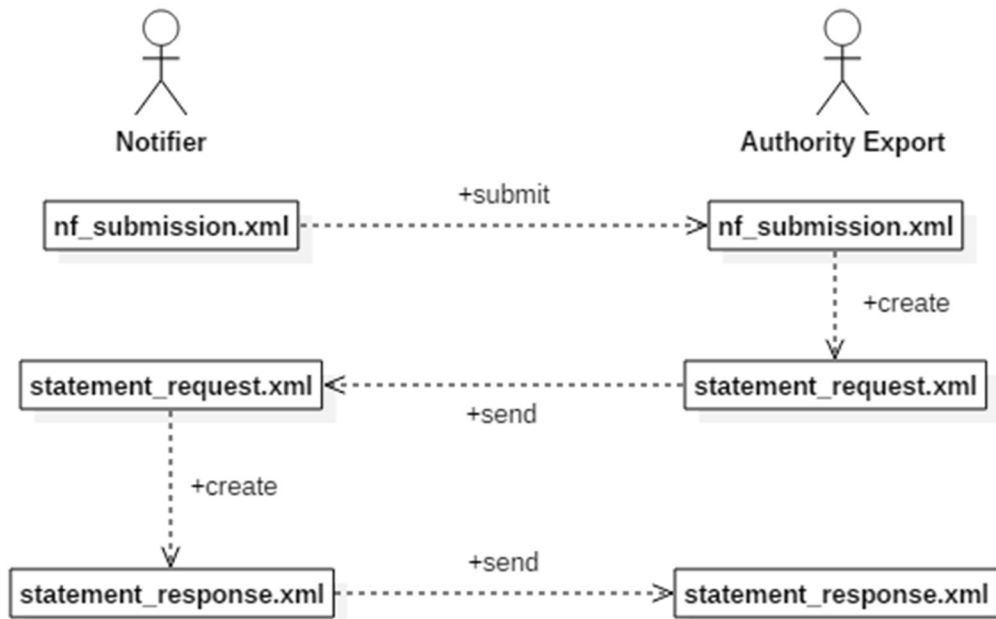

Figure 7 Claim missing information after submission

The example in Figure 7 shows the flow of statements in case of a missing information while submitting the notification to the competent authority of dispatch.

The competent authority of export creates upon the receipt of the submission a statement message with the following characteristics:

The *CategoryCode* is set to *request*, because the competent authority of export expects a reply from the notifier.

The *TypeCode* is *RequestForNotificationInformation* to indicate the purpose of the request more precisely.

The *Statement* contains arbitrary text for further details to the notifier.

The *ReferToID* references the original submission message. The *ReplyToID* is empty, because no subsequent statement exists.

In Response to the request, the notifier creates a message using the statement type including an attachment containing the missing information. The *CategoryCode* is set to **inform**, because the notifier doesn't expect to get a reply from the competent authority of dispatch.

The *ReferToID* is the same as in the request, as the statement still refers to the original submission message. The *ReplyToID* contains the *MessageID* of the Request-Statement sent by the competent authority.

## 2. Case: Correction

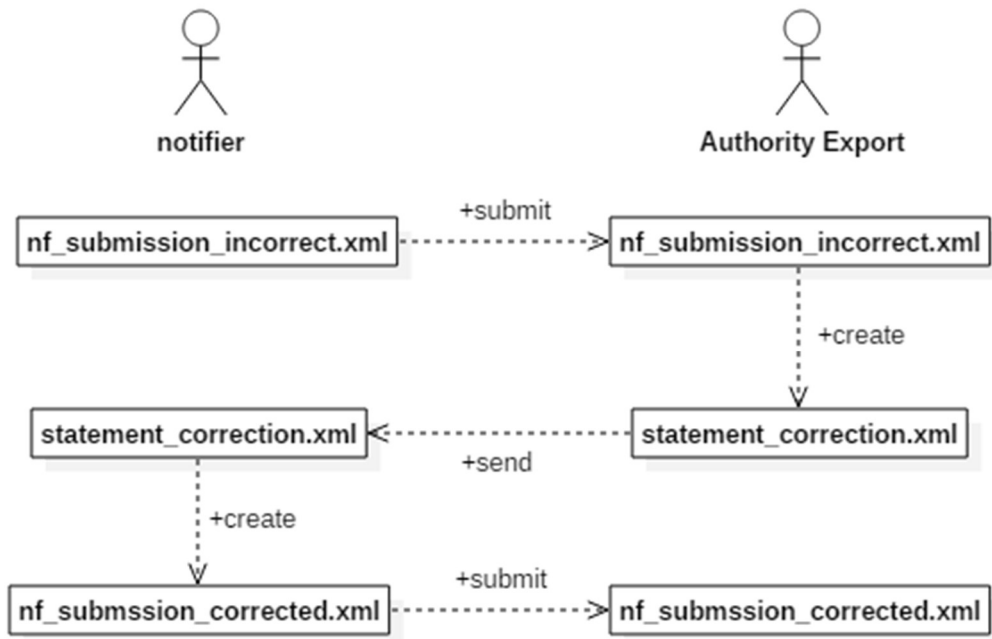

Figure 8 request correction of submission

The example in Figure 8 demonstrates the request for a correction of the submitted notification. In the message contained in the example file *nf\_submission\_incorrect.xml* the dates for first and last shipment date were accidentally swapped.

When realizing the error, the competent authority of export sends a statement with *CategoryCode request* because it expects a reply from the notifier. The text in the *Statement* element addresses the problem. *ReferToID* refers to the incorrect submission.

Upon receipt of the message the notifier corrects the submission and submits the corrected version to the competent authority of export.

The corrected submission contains the *ReferToID* of the incorrect submission and the *ReplyToID* to the message received from the competent authority of export.

## K. Electronic seals/signatures

### I. Technical aspects

#### 1. General

The data model supports the use of XMLDsig<sup>22</sup> and XAdES compliant digital signatures, used for qualified electronic seals and/or qualified electronic signatures as defined in the EU eIDAS regulation.

Regardless of whether a party uses electronic signatures or electronic seals received messages may contain them. Recommendations regarding the treatment of signed or sealed messages also apply to parties which do not seal or sign messages themselves.

In the processing of signed or sealed messages the following points must be respected in order to avoid breaking seals or signatures accidentally:

- If electronic signatures must be verified later, the stored representation must yield the same content after canonicalization<sup>23</sup> as the canonicalization did when the document was signed. The simplest way of achieving this is by storage of the unmodified message.
- Validating XML parsers modify XML documents implicitly (Normalization). Therefore they must not be used to process the messages. It may be possible to instruct validation parsers to skip the whitespace normalization but this is non-standard behaviour and there is no guarantee that every parser provides this feature.

#### 2. Creating electronic seals/signatures

In the process of creating electronic seals or signatures several parameters define how the seal/signature is applied and which algorithm may be used.

The definition of XMLDsig is very flexible, but to achieve good interoperability the following parameters from the specification must be used:

- *CanonicalizationMethod's Algorithm* attribute must be set to <http://www.w3.org/2001/10/xml-exc-c14n> (exclusive c14n ignoring comments)
- *SignatureMethod's Algorithm* attribute must be set to: <http://www.w3.org/2001/04/xmldsig-more#rsa-sha256>
- The first *Reference-Element* must set *URI*<sup>24</sup>="" to the empty URI. This takes the document as context for the signature and ignoring XML comments.
- The *Transforms* element defines in more detail which part of the XML instance is taken into account.
  - First Transform must always be  
`<ds:Transform Algorithm="http://www.w3.org/2000/09/xmldsig#enveloped-signature"/>`
  - The algorithm *xpath-filtering* (<http://www.w3.org/2002/06/xmldsig-filter2>) is an efficient way to define the scope. *xpath* is also possible, but computationally way more expansive. Therefore the following filter conditions must be used:

---

<sup>22</sup> <https://www.w3.org/TR/2002/REC-xmldsig-core-20020212/>

<sup>23</sup> <https://www.w3.org/TR/2001/REC-xml-c14n-20010315>

<sup>24</sup> <https://www.w3.org/TR/xmldsig-core1/#sec-URI> (end of paragraph)

- Filter: “intersect” here()/ancestor::\*[4]  
take all elements for levels higher than here
- Filter: “subtract” here()/ancestor::\*[4]/\*[namespace-uri()='http://www.w3.org/2000/09/xmldsig#' and local-name()='Signature']  
omit all elements which are signatures by themselves. If an additional signature is applied it doesn't sign the ones already contained in the document. It only signs the content of the document.  
This definition omits the usage of namespace prefixes<sup>25</sup> because it is known vulnerability called “namespace injection” which allow an attacker to inject wrong content without breaking the signature<sup>26</sup>
  - Last Transform must always be  
<ds:Transform Algorithm="http://www.w3.org/2001/10/xml-exc-c14n"/>
- *DigestValue's Algorithm* must be set to <http://www.w3.org/2001/04/xmlenc#sha256>
- *KeyInfo/X509Data/X509Certificate* must contain the certificate used in signing the document.
- The *ClaimedRole* element in the XAdES must be set to the PartyUUID of the block to which the signature or seal is related.

## II. Example of a seal or signature

For an example of a seal or signature complying with the recommendations of this specification see file `signature.xml`.

## III. Seal and signature coverage

Technically all signatures and seals cover the complete message. The type of commitment expressed via a seal or a signature and the message contents covered are defined by the Waste Shipment Regulation.

---

<sup>25</sup> [http://www.ws-attacks.org/XML\\_Signature\\_Wrapping\\_-\\_with\\_Namespace\\_Injection#Prefix-free\\_XPath](http://www.ws-attacks.org/XML_Signature_Wrapping_-_with_Namespace_Injection#Prefix-free_XPath)

<sup>26</sup> [http://www.cs.jhu.edu/~sdoshi/jhuisi650/papers/spimacs/SPIMACS\\_CD/sws/p29.pdf](http://www.cs.jhu.edu/~sdoshi/jhuisi650/papers/spimacs/SPIMACS_CD/sws/p29.pdf)

## Annex 1: Conceptual Data Model

### Contents

Notification Document.....	44
Movement Document.....	62
Annex VII Document.....	79

The Conceptual Data Model has been generated from the blocks and fields of the Annex IA, IB and VII including information regarding the type, length and description extracted from the XSD as well as references to Annex 2.

It should be noted that Country Role ID (block 15) and listID regarding the waste codes are not fields by themselves but positional information where to find the corresponding field in the annexes IA, IB and VIII.

It should also be noted that the column *Data Element Name* contains conceptual names not always matching the name actually defined in the XSD files.

The column *Description* provides the extracted definitions from the XSD files which are identical to the definitions in Annex 2.

The purpose of the column *Reference* is to connect the types in Annex 1 to the detailed description of Annex 2 by providing a hyperlink to the corresponding type description.

Rows written in this color can have the following different meanings:

- A field in the annex is derived from another field, see description in notes.
- recurring blocks of fields are only referenced and not repeated to minimize redundancy.

## Notification Document

WSR document	WSR block no	WSR block name	WSR data element name	Type	Data type length	Data Element Name	Description	Reference
Notification Annex IA	1	Exporter-Notifier				Notifier	ID, name, address and contact of the notifier. Note: Corresponds to block 1 of Annex IA WSR.	<a href="#">SubmissionType / Notifier</a>
Notification Annex IA	1	Exporter-Notifier	reg nb	token	64	Registration number	Party identifiers (registration no) such as the VAT number (Value Added Tax) or GLN (Global Location Number). Note: For each classification scheme only one identifier is allowed.	<a href="#">PartyType / PartyID</a>
Notification Annex IA	1	Exporter-Notifier	name	normalizedString	256	Organization Name	Party name for parties which are not natural persons.	<a href="#">PartyType / OrganizationName</a>
Notification Annex IA	1	Exporter-Notifier	name	normalizedString	100	Given Name	The person's given name.	<a href="#">PersonType / GivenName</a>
Notification Annex IA	1	Exporter-Notifier	name	normalizedString	100	Family Name	The person's family name.	<a href="#">PersonType / FamilyName</a>
Notification Annex IA	1	Exporter-Notifier	address	string	3	Country ID	The ISO 3166-1 numeric 3 code specifying the country of this address.	<a href="#">AddressType / CountryID</a>

Notification Annex IA	1	Exporter-Notifier	address	token	10	Post Code	The post code. Note: The post code is expected to not include a country identifier.	<a href="#">AddressType</a> / Postcode
Notification Annex IA	1	Exporter-Notifier	address	token	45	City Name	The city name (name of a city, town or village).	<a href="#">AddressType</a> / CityName
Notification Annex IA	1	Exporter-Notifier	address	token	46	Street Name	The street name.	<a href="#">AddressType</a> / StreetName
Notification Annex IA	1	Exporter-Notifier	address	token	15	Building Number	The building number.	<a href="#">AddressType</a> / BuildingNumber
Notification Annex IA	1	Exporter-Notifier	address	token	45	City Sub-Division Name	The city sub-division name, such as the name of a district or borough. Note: City sub-division names are relatively uncommon in addresses.	<a href="#">AddressType</a> / CitySubDivisionName
Notification Annex IA	1	Exporter-Notifier	address	token	32	Block Name	The block name. Note 1: A block is an area surrounded by streets and usually containing several buildings. Note 2: In Europe, block names are relatively uncommon in addresses.	<a href="#">AddressType</a> / BlockName

Notification Annex IA	1	Exporter-Notifier	address	token	30	Post Office Box	The post office box identifier. Note: Post office box addresses may be acceptable for addresses such as head office addresses, but must not be used for addresses which need to be locatable, such as site addresses.	<a href="#">AddressType</a> / PostOfficeBox
Notification Annex IA	1	Exporter-Notifier	address	token	7	Staircase Number	The staircase number.	<a href="#">AddressType</a> / StaircaseNumber
Notification Annex IA	1	Exporter-Notifier	address	token	7	Floor Identification	The floor number or identifier.	<a href="#">AddressType</a> / FloorIdentification
Notification Annex IA	1	Exporter-Notifier	address	token	7	Room Identification	The room number or identifier (identification of a room, suite, office, apartment, etc.).	<a href="#">AddressType</a> / RoomIdentification
<a href="#">Notification Annex IA</a>	1	<a href="#">Exporter-Notifier</a>	<a href="#">contact</a>			<a href="#">see name</a>	<a href="#">Details on a person, such as name and gender.</a>	<a href="#">PartyType</a> / <a href="#">PersonType</a>
Notification Annex IA	1	Exporter-Notifier	tel	string	48	Telephone Number	The complete contact phone number. Examples: +49 1 234 5678, 0049 1 234 5678	<a href="#">ContactType</a> / TelephoneCompleteNumber
Notification Annex IA	1	Exporter-Notifier	fax	string	48	Fax Number	The complete contact fax number.	<a href="#">ContactType</a> / FaxCompleteNumber
Notification Annex IA	1	Exporter-Notifier	email	token	200	Email URI	The contact email address. Example: "office@example.com"	<a href="#">ContactType</a> / EmailURI



Notification Annex IA	2	Importer-Consignee				see Exporter-Notifier	ID, name, address and contact of the consignee. Note: Corresponds to block 2 of Annex IA WSR.	<a href="#">SubmissionType / Consignee</a>
Notification Annex IA	3	Notification	Nb	token	100	Notification Number	The notification number assigned to the notification by the Competent Authority of Dispatch or an IT solution on its behalf. Example: "DE 030855" Note: By convention, the notification number is expected to start with the ISO 3166-1 alpha-2 country code, such as 'DE' or 'IT'.	<a href="#">NotificationDocumentType / NotificationID</a>
Notification Annex IA	3	Notification	Individual / multiple				no data element (automatically derived from number of shipments)	
Notification Annex IA	3	Notification	Diposal / recovery				no data element (automatically derived from block 11)	
Notification Annex IA	4	Total	Nb shipments	positiveInteger	8	Shipment Quantity	The total intended number of shipments under this notification. Note: Corresponds to block 4 of Annex IA WSR.	<a href="#">SubmissionType / ShipmentQuantity</a>
Notification Annex IA	5	Total qty	Tons	decimal	25	Mass Measurement Value	The mass of waste together with the unit of measurement, such as "t" for tonnes. Note: Within the EU the mass of waste must be specified with unit "t" for tonnes.	<a href="#">NotificationMassVolumeMeasureType / MassMeasure</a>

Notification Annex IA	5	Total qty	Tons	token	64	Mass Measurement Unit	The case sensitive (c/s) Unified Code for Units of Measure (UCUM) for this measurement. Example: "t" for tonnes, "kg" for kilograms, "m3" for cubic meters or "l" for liters.	<a href="#">MeasureType / unitCode</a>
Notification Annex IA	5	Total qty	Tons	decimal	25	Min Mass Measurement Value	The minimum amount (mass) of waste intended to be shipped, expressed in tonnes ("t"). Note: Corresponds to Annex IC No. 17 of the WSR.	<a href="#">NotificationMassVolumeMeasureType / MinimumMassMeasure</a>
Notification Annex IA	5	Total qty	Tons	token	64	Min Measurement Unit	The case sensitive (c/s) Unified Code for Units of Measure (UCUM) for this measurement. Example: "t" for tonnes, "kg" for kilograms, "m3" for cubic meters or "l" for liters.	<a href="#">MeasureType / unitCode</a>
Notification Annex IA	5	Total qty	Tons	decimal	25	Max Mass Measurement Value	The maximum amount (mass) of waste intended to be shipped, expressed in tonnes ("t"). Note: Corresponds to Annex IC No. 17 of the WSR.	<a href="#">NotificationMassVolumeMeasureType / MaximumMassMeasure</a>
Notification Annex IA	5	Total qty	Tons	token	64	Max Mass Measurement Unit	The case sensitive (c/s) Unified Code for Units of Measure (UCUM) for this measurement. Example: "t" for tonnes, "kg" for kilograms, "m3" for cubic meters or "l" for liters.	<a href="#">MeasureType / unitCode</a>

Notification Annex IA	5	Total qty	m <sup>3</sup>	decimal	25	Volume Measurement Value	The volume of waste together with the unit of measurement, such as "m3" for cubic meters or "l" for liters. Note: Within the EU, only the mass of waste in tonnes ("t") is expected, whereas the volume of waste is not expected to be specified.	<a href="#">NotificationMassVolumeMeasureType</a> / VolumeMeasure
Notification Annex IA	5	Total qty	m <sup>3</sup>	token	64	Volume Mass Measurement Unit	The case sensitive (c/s) Unified Code for Units of Measure (UCUM) for this measurement. Example: "t" for tonnes, "kg" for kilograms, "m3" for cubic meters or "l" for liters.	<a href="#">MeasureType</a> / unitCode
Notification Annex IA	6	Period	First dep	date		First Start Date	The start date of the first intended shipment of waste under this notification.	<a href="#">ShipmentPeriodType</a> / FirstStartDate
Notification Annex IA	6	Period	Last dep	date		Last Start Date	The start date of the last intended shipment of waste under this notification.	<a href="#">ShipmentPeriodType</a> / LastStartDate
Notification Annex IA	7	Packaging	Types	token	{1,2,3,4,5,6,7,8}	Packaging Type Code	A code specifying the type of package. Example: "6" for "composite packaging".	<a href="#">PackagingType</a> / PackageTypeCode
Notification Annex IA	7	Packaging	Other Types	string	1024	Package Type Description	Description of the type of packaging. Note: A description is expected if none of the packaging types 1 to 8 of Annex IA and Annex IB applies, and can also be provided in addition to packaging types 1 to 8.	<a href="#">PackagingType</a> / PackageDescription
Notification Annex IA	7	Packaging	Special Requirements	boolean		Special Handling Requirement Indicator	An indication of whether or not special handling is required for the packages.	<a href="#">PackagingType</a> / SpecialHandlingRequirementIndicator

Notification Annex IA	8	Intended Carrier				see Exporter-Notifier	ID, name, address and contact of parties intended to carry the waste. Note: Corresponds to block 8 of Annex IA WSR.	<a href="#">SubmissionType / Carrier</a>
Notification Annex IA	8	Intended Carrier	Means of transport	token	{A,R,S,T,W}	Transport Means Type Code	A code specifying the means of transport for this carrier. Example: "R" for road, "T" for train. Note: The WSR may define different codes in its various translations. In the electronic data interchange the codes from the English version of the regulation MUST be used, independent of the countries involved and independent of the language used in the document.	<a href="#">CarrierType / MeansOfTransportCode</a>
Notification Annex IA	9	Waste generator(s) - Producer(s)				see Exporter-Notifier	ID, name, address and contact of producers of the waste intended to be carried. Note: Corresponds to block 9 of Annex IA WSR.	<a href="#">SubmissionType / WasteProducer</a>
Notification Annex IA	9	Waste generator(s) - Producer(s)	Site of generation	string	1024	Site description	The description of the waste production site, such as name and address.	<a href="#">WasteProducerType / SiteDescription</a>
Notification Annex IA	9	Waste generator(s) - Producer(s)	Process of generation	string	1024	Process description	The description of the waste production process.	<a href="#">WasteProducerType / ProcessDescription</a>

Notification Annex IA	10	Disposal / Recovery Facility	Nature of facility				will be automatically derived from the recovery/disposal operations specified for that facility	
Notification Annex IA	10	Disposal / Recovery Facility				see Exporter-Notifier	ID, name, address, contact and site of the first interim recovery or disposal facility. Note 1: Corresponds to Annex II Part 1 point 5 WSR. Note 2: This element is omitted if there is no interim recovery or disposal. Note 3: If there is interim recovery or disposal, then this element corresponds to blocks 10 and 11 of Annex IA WSR.	<u>SubmissionType</u> / InitialInterimRecoveryDisposalFacility
Notification Annex IA	10	Disposal / Recovery Facility				see Exporter-Notifier	ID, name, address, contact and site of subsequent interim recovery or disposal facilities. Note 1: Corresponds to Annex II Part 1 point 5 WSR. Note 2: This element is omitted if there is no interim recovery or disposal or no subsequent interim recovery or disposal.	<u>SubmissionType</u> / SubsequentInterimRecoveryDisposalFacility

Notification Annex IA	10	Disposal / Recovery Facility				see Exporter-Notifier	ID, name, address, contact and site of non-interim recovery or disposal facilities. Note 1: If there is no interim recovery or disposal, then only one non-interim recovery or disposal facility is expected. If there is interim recovery or disposal, there can be multiple non-interim recovery or disposal facilities. Note 2: If there is no interim recovery or disposal, this element corresponds to blocks 10 and 11 of Annex IA WSR.	<a href="#">SubmissionType / NonInterimRecoveryDisposalFacility</a>
Notification Annex IA	10	Disposal / Recovery Facility	Site of generation	string	1024	Site Description	The description of the site of disposal or recovery such as name and address.	<a href="#">RecoveryDisposalFacilityType / SiteDescription</a>
Notification Annex IA	11	Disposal / Recovery operation(s)	D-code-R-code	token	D1-D15, R1-R13	Recovery Disposal Type Code	A code specifying the type of recovery or disposal conducted at the facility. Example: "R2" for "Solvent reclamation/regeneration".	<a href="#">RecoveryDisposalFacilityType / RecoveryDisposalTypeCode</a>
Notification Annex IA	11	Disposal / Recovery operation(s)	Technology	string	1024	Technology Description	The description of the facility's recovery or disposal technology.	<a href="#">RecoveryDisposalFacilityType / TechnologyDescription</a>

Notification Annex IA	11	Disposal / Recovery operation(s)	Reason for export	string	1024	Reason for export Description	The description of the reason for export to this facility where required by a competent authority outside the OECD. Duly motivated request from the country of dispatch in case of imports into the EU of wastes destined for disposal (Annex IA block 11 and Annex IC para. 22); Note: Binary attachments can provide further information in addition to this description	<a href="#">RecoveryDisposalFacilityType</a> / ReasonForExportDescription
Notification Annex IA	12	Designation and composition of wastes	Waste Designation	string	1024	WasteDesignationDescription	Designation of the waste intended to be shipped. Note 1: Corresponds to block 12 of Annex IA WSR Note 2: In case of additional information that would facilitate the identification of the waste would be needed corresponding to block 14 (vi) this element can be used to respect Annex IC para. 25(e).	<a href="#">SubmissionType</a> / WasteDesignationDescription
Notification Annex IA	13	Physical characteristics	Physical Characteristics	token	{1,2,3,4,5,6}	Physical Characteristic Type Code	Code specifying the physical characteristic of the waste intended to be shipped. Note: Corresponds to block 13 of Annex IA WSR. Example: "4" for "sludgy".	<a href="#">SubmissionType</a> / PhysicalCharacteristicTypeCode

Notification Annex IA	13	Physical characteristics	Other characteristics	string	1024	Physical Characteristic Description	Description of the physical characteristics of the waste intended to be shipped. Note 1: Corresponds to block 13 of Annex IA WSR. Note 2: A description is expected if none of the physical characteristics 1 to 6 of Annex IA and Annex IB applies, and can also be provided in addition to physical characteristics 1 to 6	<a href="#">SubmissionType</a> / PhysicalCharacteristicDescription
Notification Annex IA	14	Waste identification	(i-xii) waste identification codes	token	64	Waste Code Type	A code specifying a type of waste, in combination with a listID or listName attribute specifying the list from which the waste type code is taken.	<a href="#">WasteClassificationType</a> / WasteCodeType
Notification Annex IA	14	Waste identification		token	{BASEL,CUST,EWL,HCODE,IWIC,NATEXP,NATIMP,OECD,OTHER,UNCLASS,UNNUM,UNSHIP,YCODE,ANNEX3A,ANNEX3B}	WasteCodeType / listID	The code specifying the waste list. Example: "EWL" for European Waste List. Note: Instead of referencing one of the enumerated waste lists such as European Waste List this can alternatively be set to a country code for a national waste classification.	<a href="#">WasteCodeType</a> / listID
Notification Annex IA	15	Countries / states concerned	Export State / Country Code	string	3	Country ID	The ISO 3166-1 numeric 3 code specifying the country.	<a href="#">ConcernedCountryType</a> / CountryID



Notification Annex IA	15	Countries / states concerned	Export State / Authority Code	token	64	Authority ID	Competent authority identifier. Note: Where available, identifiers are taken from the following list: <a href="http://ec.europa.eu/environment/waste/shipments/pdf/list_competent_authorities.pdf">http://ec.europa.eu/environment/waste/shipments/pdf/list_competent_authorities.pdf</a>	<a href="#">CompetentAuthorityType</a> / CompetentAuthorityID
Notification Annex IA	15	Countries / states concerned	Export State / Exit Point	normalizedString	256	Exit Point Name	The name of the point of exit in the country of dispatch.	<a href="#">ExportStateType</a> / ExitPointName
Notification Annex IA	15	Countries / states concerned	Transit State / Country Code	string	3	CountryID	The ISO 3166-1 numeric 3 code specifying the country.	<a href="#">ConcernedCountryType</a> / CountryID
Notification Annex IA	15	Countries / states concerned	Transit State / Authority Code	token	64	Authority ID	Competent authority identifier. Note: Where available, identifiers are taken from the following list: <a href="http://ec.europa.eu/environment/waste/shipments/pdf/list_competent_authorities.pdf">http://ec.europa.eu/environment/waste/shipments/pdf/list_competent_authorities.pdf</a>	<a href="#">CompetentAuthorityType</a> / CompetentAuthorityID
Notification Annex IA	15	Countries / states concerned	Transit State / Entry Point	normalizedString	256	Entry Point Name	The name of the point of entry in the country of transit.	<a href="#">TransitStateType</a> / EntryPointName
Notification Annex IA	15	Countries / states concerned	Transit State / Exit Point	normalizedString	256	Exit Point Name	The name of the point of exit in the country of transit.	<a href="#">TransitStateType</a> / ExitPointName

Notification Annex IA	15	Countries / states concerned	Import State / Country Code	string	3	Country ID	The ISO 3166-1 numeric 3 code specifying the country.	<a href="#">ConcernedCountryType</a> / CountryID
Notification Annex IA	15	Countries / states concerned	Import State / Authority Code	token	64	Authority ID	Competent authority identifier. Note: Where available, identifiers are taken from the following list: <a href="http://ec.europa.eu/environment/waste/shipments/pdf/list_competent_authorities.pdf">http://ec.europa.eu/environment/waste/shipments/pdf/list_competent_authorities.pdf</a>	<a href="#">CompetentAuthorityType</a> / CompetentAuthorityID
Notification Annex IA	15	Countries / states concerned	Import State / Entry Point	normalizedString	256	Entry Point Name	The name of the point of entry in the country of destination.	<a href="#">ImportStateType</a> / EntryPointName
Notification Annex IA	16	EC Customs office	Entry	normalizedString	256	Customs office of entry name	The name of the customs office of entry into the Community for shipments of waste under this notification. Note: Corresponds to block 16 of Annex IA WSR.	<a href="#">SubmissionType</a> / CustomsOfficeEntryName
Notification Annex IA	16	EC Customs office	Exit	normalizedString	256	Customs office of exit name	The name of the customs office of exit from the Community for shipments of waste under this notification. Note: Corresponds to block 16 of Annex IA WSR.	<a href="#">SubmissionType</a> / CustomsOfficeExitName

Notification Annex IA	16	EC Customs office	Export	normalizedString	256	Customs office of export name	The name of the customs office of export from the Community for shipments of waste under this notification. Note: Corresponds to block 16 of Annex IA WSR.	<a href="#">SubmissionType</a> / CustomsOfficeExportName
Notification Annex IA	17	Declaration	Exporter-Notifier name	normalizedString	256	Declaration Notifier Name	The name provided under the declaration. Note: This is text intended to be printed/displayed at the name element of a declaration following the Annex IA/IB/VII layouts of the WSR.	<a href="#">DeclarationType</a> / Name
Notification Annex IA	17	Declaration	Exporter-Notifier date	date		Declaration Notifier Date	The date of the declaration.	<a href="#">DeclarationType</a> / Date
Notification Annex IA	17	Declaration	Exporter-Notifier signature	string	256	Declaration Notifier Signature Text	Text to be printed/displayed at the signature element of a declaration following the Annex IA/IB/VII layouts of the WSR. Note: This text may be auto-generated from an actual electronic signature by the software generating the message.	<a href="#">DeclarationType</a> / Signature
Notification Annex IA	17	Declaration	Generator-Producer name	normalizedString	256	Declaration Producer Name	The name provided under the declaration. Note: This is text intended to be printed/displayed at the name element of a declaration following the Annex IA/IB/VII layouts of the WSR.	<a href="#">DeclarationType</a> / Name

Notification Annex IA	17	Declaration	Generator-Producer date	date		Declaration Producer Date	The date of the declaration.	<a href="#">DeclarationType / Date</a>
Notification Annex IA	17	Declaration	Generator-Producer signature	string	256	Declaration Producer Signature Text	Text to be printed/displayed at the signature element of a declaration following the Annex IA/IB/VII layouts of the WSR. Note: This text may be auto-generated from an actual electronic signature by the software generating the message.	<a href="#">DeclarationType / Signature</a>
Notification Annex IA	18	Number of annexes attached	Number of Annexes	nonNegativeInteger	8	Annex Quantity	The number of annexes to this notification. Note: IT systems may automatically pre-fill this element with the number of actual electronic annexes, but should also support manual entry of the number of annexes.	<a href="#">SubmissionType / AnnexQuantity</a>
Notification Annex IA	19	Acknowledgment from authority	Country	string	3	Country ID	The ISO 3166-1 numeric 3 code specifying the country of the competent authority providing the acknowledgment.	<a href="#">AcknowledgementType / CountryID</a>
Notification Annex IA	19	Acknowledgment from authority	Notification received on	date		Notification Receipt Date	The date at which the competent authority received the notification submission.	<a href="#">AcknowledgementType / ReceiptDate</a>
Notification Annex IA	19	Acknowledgment from authority	Acknowledgment sent on	date		Acknowledgment Sent Date	The date at which the competent authority sent the acknowledgment.	<a href="#">AcknowledgementType / SentDate</a>

Notification Annex IA	19	Acknowledgment from authority	Authority Code	token	64	Authority ID	Competent authority identifier. Note: Where available, identifiers are taken from the following list: <a href="http://ec.europa.eu/environment/waste/shipments/pdf/list_competent_authorities.pdf">http://ec.europa.eu/environment/waste/shipments/pdf/list_competent_authorities.pdf</a>	<a href="#">CompetentAuthorityType</a> / CompetentAuthorityID
Notification Annex IA	19	Acknowledgment from authority	Authority Name	normalizedString	256	Authority Name	Party name for parties which are not natural persons.	<a href="#">PartyType</a> / OrganizationName
Notification Annex IA	19	Acknowledgment from authority	Stamp or signature	string	256	Stamp Signature Text	Text to be printed/displayed at the competent authority's stamp and signature element in a layout following Annex IA of the WSR.	<a href="#">AcknowledgementType</a> / CompetentAuthorityStampSignature
Notification Annex IA	20	Written Consent to the movement	Country	string	3	Country ID	The ISO 3166-1 numeric 3 code specifying the country of the competent authority providing the decision.	<a href="#">DecisionType</a> / CountryID
Notification Annex IA	20	Written Consent to the movement	Given on	date		Consent Given on	The date at which the competent authority decided over the notification.	<a href="#">DecisionType</a> / DecisionDate

Notification Annex IA	20	Written Consent to the movement	Valid from	date		Consent Valid from	The date from which the consent is valid. Note: This element must not be used with objections, i.e. it must not be used in combination with the ConsentGrantedIndicator set to false.	<a href="#">DecisionType / ValidFromDate</a>
Notification Annex IA	20	Written Consent to the movement	Valid to	date		Consent Valid to	The date up to which the consent is valid. Note: This element must not be used with objections, i.e. it must not be used in combination with the ConsentGrantedIndicator set to false.	<a href="#">DecisionType / ValidToDate</a>
Notification Annex IA	20	Written Consent to the movement	Authority Code	token	64	Authority ID	Competent authority identifier. Note: Where available, identifiers are taken from the following list: <a href="http://ec.europa.eu/environment/waste/shipments/pdf/list_competent_authorities.pdf">http://ec.europa.eu/environment/waste/shipments/pdf/list_competent_authorities.pdf</a>	<a href="#">CompetentAuthorityType / CompetentAuthorityID</a>
Notification Annex IA	20	Written Consent to the movement	Authority Name	normalizedString	256	Authority Name	Party name for parties which are not natural persons.	<a href="#">PartyType / OrganizationName</a>
Notification Annex IA	20	Written Consent to the movement	Stamp or signature	string	256	Stamp Signature Text	Text to be printed/displayed at the competent authority's stamp and signature element in a layout following Annex IA of the WSR.	<a href="#">DecisionType / CompetentAuthorityStampSignature</a>

Notification Annex IA	21	Specific conditions	Specific conditions ?	boolean		Specific Condition Indicator	The indication of whether or not there are specific conditions under which the consent is granted. Note: This element must not be used with objections, i.e. it must not be used in combination with the ConsentGrantedIndicator set to false.	<a href="#">DecisionType</a> / SpecificConditionIndicator
Notification Annex IA	21	Specific conditions	Specific conditions	string	1024	Specific Condition Description	The description of the specific conditions under which the consent is granted. Note: The description of specific conditions is expected if and only if there is a SpecificConditionIndicator set to true.	<a href="#">DecisionType</a> / SpecificConditionDescription

## Movement Document

WSR document	WSR block no	WSR block name	WSR data element name	Type	Data type length	Data Element Name	Descriptions	Reference
Movement Annex IB	1	Corresponding to notification	Notification Number	token	100	NotificationID	The number of the notification under which the shipment of waste has been consented. Note: Corresponds to block 1 of Annex IB WSR.	<a href="#">WasteMovementDocumentType</a> / NotificationID
Movement Annex IB	2	Shipment Number	Shipment Number	positiveInteger	8	Sequence Number	A sequential number assigned to the shipment of waste, enumerating all the shipments of waste under one notification, with "1" assigned to the first shipment, "2" to the second, and so on. Note 1: A sequence number typically must not be reused. This also applies when shipments of waste are cancelled. The number of the cancelled shipment must not be reused for a new shipment. Note 2: Corresponds to block 2 of Annex IB WSR.	<a href="#">WasteMovementDocumentType</a> / SequenceNumber
Movement Annex IB	2	Shipment Number	Shipment Number	positiveInteger	8	Total Number	The total number of shipments consented under the notification. Note: Corresponds to block 2 of Annex IB WSR.	<a href="#">WasteMovementDocumentType</a> / ShipmentQuantity



Movement Annex IB	3	Exporter-Notifier				see Exporter-Notifier Annex IA	The notifier of this shipment of waste. Note 1: Must be identical to the notifier named in the notification under which this shipment has been consented. Note 2: Corresponds to block 3 of Annex IB WSR.	<a href="#">TransportAnnouncementType / Notifier</a>
Movement Annex IB	4	Importer-Consignee				see Exporter-Notifier	The consignee of this shipment of waste. Note 1: Must be identical to the consignee named in the notification under which this shipment has been consented. Note 2: Corresponds to block 4 of Annex IB WSR.	<a href="#">TransportAnnouncementType / Consignee</a>
Movement Annex IB	5	Actual quantity	Tons	decimal	25	Mass Measurement Value	The mass of waste together with the unit of measurement, such as "t" for tonnes. Note: Within the EU the mass of waste must be specified with unit "t" for tonnes.	<a href="#">MassVolumeMeasureType / MassMeasure</a>
Movement Annex IB	5	Actual quantity	Tons	token	64	Mass Measurement Unit	The case sensitive (c/s) Unified Code for Units of Measure (UCUM) for this measurement. Example: "t" for tonnes, "kg" for kilograms, "m3" for cubic meters or "l" for liters.	<a href="#">MassVolumeMeasureType / unitCode</a>

Movement Annex IB	5	Actual quantity	m <sup>3</sup>	decimal	25	Volume Measurement Value	The volume of waste together with the unit of measurement, such as "m3" for cubic meters or "l" for liters. Note: Within the EU, only the mass of waste in tonnes ("t") is expected, whereas the volume of waste is not expected to be specified.	<a href="#">MassVolumeMeasureType</a> / VolumeMeasure
Movement Annex IB	5	Actual quantity	m <sup>3</sup>	token	64	Volume Mass Measurement Unit	The case sensitive (c/s) Unified Code for Units of Measure (UCUM) for this measurement. Example: "t" for tonnes, "kg" for kilograms, "m3" for cubic meters or "l" for liters.	<a href="#">MassVolumeMeasureType</a> / unitCode
Movement Annex IB	6	Actual shipment date	Shipment Date	date		Start Date	The start date of this shipment of waste. Note: Corresponds to block 6 of Annex IB WSR.	<a href="#">TransportAnnouncementType</a> / StartDate
Movement Annex IB	7	Packaging	Types	token	{1,2,3,4,5,6,7,8}	Packaging Type Code	A code specifying the type of package. Example: "6" for "composite packaging".	<a href="#">PackagingType</a> / PackageTypeCode
Movement Annex IB	7	Packaging	Other Types	string	1024	Other Types Description	Description of the type of packaging. Note: A description is expected if none of the packaging types 1 to 8 of Annex IA and Annex IB applies, and can also be provided in addition to packaging types 1 to 8.	<a href="#">PackagingType</a> / PackageDescription
Movement Annex IB	7	Packaging	No of packages	positiveInteger	8	Packaging Quantity	The number of packages in this shipment of waste.	<a href="#">MovementPackagingType</a> / PackageQuantity

Movement Annex IB	7	Packaging	Special Requirements	boolean		Special Handling Requirement Indicator	An indication of whether or not special handling is required for the packages.	<a href="#">PackagingType / SpecialHandlingRequirementIndicator</a>
Movement Annex IB	8	Carriers				see Exporter-Notifier	Carriers conducting this shipment of waste. Note 1: Corresponds to block 8 of Annex IB WSR, without the part marked as "to be completed by the carrier's representative". Note 2: Each of the carriers must be a carrier named in the notification under which this shipment of waste has been consented.	<a href="#">TransportAnnouncementType / Carrier</a>
Movement Annex IB	8	Carriers	Means of Transport	token	{A,R,S,T,W}	Transport Means Type Code	A code specifying the means of transport for this carrier. Example: "R" for road, "T" for train. Note: The WSR may define different codes in its various translations. In the electronic data interchange the codes from the English version of the regulation MUST be used, independent of the countries involved and independent of the language used in the document.	<a href="#">CarrierType / MeansOfTransportCode</a>
Movement Annex IB	8	Transport				see Exporter-Notifier	Waste shipment related information provided by carriers. Note: Corresponds to the part marked as "to be completed by carrier's representative" under block 8 of Annex IB WSR.	<a href="#">WasteMovementDocumentType / Transport</a>

Movement Annex IB	8	Transport	Means of Transport	token	{A,R,S,T,W}	Transport Means Type Code	A code specifying the means of transport for this carrier. Example: "R" for road, "T" for train. Note: The WSR may define different codes in its various translations. In the electronic data interchange the codes from the English version of the regulation MUST be used, independent of the countries involved and independent of the language used in the document.	<a href="#">CarrierType</a> / MeansOfTransportCode
Movement Annex IB	8	Transport	Date of Transfer	date		Transfer Date	The date of waste transfer.	<a href="#">TransportType</a> / TransferDate
Movement Annex IB	8	Transport	Signature	string	256	Carrier Signature Text	Text to be printed/displayed at the carrier's signature element in a layout following Annex IB or Annex VII of the WSR.	<a href="#">TransportType</a> / CarrierSignatureText
Movement Annex IB	9	Waste Generator(s) - producer(s)				see Exporter-Notifier	Producers of the waste to be shipped. Note 1: Corresponds to block 9 of Annex IB WSR. Note 2: Each of the producers must be a producer named in the notification under which this shipment of waste has been consented.	<a href="#">TransportAnnouncementType</a> / WasteProducer
Movement Annex IB	10	Disposal / Recovery Facility	Nature of facility				will be automatically derived from the recovery/disposal operations specified for that facility	

Movement Annex IB	10	Disposal / Recovery Facility				see Exporter-Notifier	<p>ID, name, address, contact and site of the first interim recovery or disposal facility.</p> <p>Note 1: Corresponds to Annex II Part 1 point 5 of WSR.</p> <p>Note 2: This element is omitted if there is no interim recovery or disposal.</p> <p>Note 3: If there is interim recovery or disposal, then this element corresponds to blocks 10 and 11 of Annex IB WSR.</p> <p>Note 4: InitialInterimRecoveryDisposal, SubsequentInterimRecoveryDisposal and NonInterimRecoveryDisposal must be identical to the elements of the same name in the notification under which this shipment has been consented regarding provision, omission and contents.</p>	<p><u>TransportAnnouncementType / InitialInterimRecoveryDisposalFacility</u></p>
-------------------	----	------------------------------	--	--	--	-----------------------	--	--

Movement Annex IB	10	Disposal / Recovery Facility				see Exporter-Notifier	<p>ID, name, address, contact and site of subsequent interim recovery or disposal facilities.</p> <p>Note 1: Corresponds to Annex II Part 1 point 5 of WSR.</p> <p>Note 2: This element is omitted if there is no interim recovery or disposal or no subsequent interim recovery or disposal.</p> <p>Note 3: InitialInterimRecoveryDisposal, SubsequentInterimRecoveryDisposal and NonInterimRecoveryDisposal must be identical to the elements of the same name in the notification under which this shipment has been consented regarding provision, omission and contents.</p>	<a href="#">TransportAnnouncementType / SubsequentInterimRecoveryDisposalFacility</a>
-------------------	----	------------------------------	--	--	--	-----------------------	---	---

Movement Annex IB	10	Disposal / Recovery Facility				see Exporter-Notifier	ID, name, address, contact and site of non-interim recovery or disposal facilities. Note 1: If there is no interim recovery or disposal, then only one non-interim recovery or disposal facility is expected. If there is interim recovery or disposal, there can be multiple non-interim recovery or disposal facilities. Note 2: If there is no interim recovery or disposal, this element corresponds to blocks 10 and 11 of Annex IB WSR. Note 3: InitialInterimRecoveryDisposal, SubsequentInterimRecoveryDisposal and NonInterimRecoveryDisposal must be identical to the elements of the same name in the notification under which this shipment has been consented regarding provision, omission and contents.	<a href="#">TransportAnnouncementType / NonInterimRecoveryDisposalFacility</a>
Movement Annex IB	10	Disposal / Recovery Facility	Site of generation	string	1024	Site Description	The description of the site of disposal or recovery such as name and address.	<a href="#">RecoveryDisposalFacilityType / SiteDescription</a>
Movement Annex IB	11	Disposal / Recovery operation(s)	D-code-R-code	token	D1-D15, R1-R13	Recovery Disposal Type Code	A code specifying the type of recovery or disposal conducted at the facility. Example: "R2" for "Solvent reclamation/regeneration".	<a href="#">RecoveryDisposalFacilityType / RecoveryDisposalTypeCode</a>

Movement Annex IB	12	Designation and composition of wastes	Waste Designation	string	1024	WasteDesignationDescription	Designation of the waste to be shipped. Note 1: Corresponds to block 12 of Annex IB WSR. Note 2: In case of additional information that would facilitate the identification of the waste would be needed corresponding to block 14 (vi) this element can be used to respect Annex IC para. 25(e).	<a href="#">TransportAnnouncementType</a> / WasteDesignationDescription
Movement Annex IB	13	Physical characteristics	Physical Characteristics	token	{1,2,3,4,5,6}	PhysicalCharacteristicTypeCode	Code specifying the physical characteristic of the waste to be shipped. Note: Corresponds to block 13 of Annex IB WSR. Example: "4" for "sludgy".	<a href="#">TransportAnnouncementType</a> / PhysicalCharacteristicTypeCode
Movement Annex IB	13	Physical characteristics	Other characteristics	string	1024	PhysicalCharacteristicDescription	Description of the physical characteristics of the waste to be shipped in case the physical characteristic 7 (other) is used. Note 1: Corresponds to block 13 of Annex IB WSR. Note 2: A description is expected if none of the physical characteristics 1 to 6 of Annex IA and Annex IB applies, and can also be provided in addition to physical characteristics 1 to 6.	<a href="#">TransportAnnouncementType</a> / PhysicalCharacteristicDescription



Movement Annex IB	14	Waste identification	(i-xii) waste identification codes	token	64	Waste Code Type	A code specifying a type of waste, in combination with a listID or listName attribute specifying the list from which the waste type code is taken.	<a href="#">WasteClassificationType</a> / WasteCodeType
Movement Annex IB	14	Waste identification		token	{BASEL,CUST,EWL,HCODE,IWIC,NATEXP,NATIMP,OECD,OTHER,UNCLASS,UNNUM,UNSHIP,YCODE,ANNEX3A,ANNEX3B}	WasteCodeType / listID	The code specifying the waste list. Example: "EWL" for European Waste List. Note: Instead of referencing one of the enumerated waste lists such as European Waste List this can alternatively be set to a country code for a national waste classification.	<a href="#">WasteCodeType</a> / listID
Movement Annex IB	15	Declaration	Exporter-Notifier name	normalizedString	256	Declaration Notifier Name	The name provided under the declaration. Note: This is text intended to be printed/displayed at the name element of a declaration following the Annex IA/IB/VII layouts of the WSR.	<a href="#">DeclarationType</a> / Name
Movement Annex IB	15	Declaration	Exporter-Notifier date	date		Declaration Notifier Date	The date of the declaration.	<a href="#">DeclarationType</a> / Date

Movement Annex IB	15	Declaration	Exporter-Notifier signature	string	256	Declaration Notifier Signature Text	Text to be printed/displayed at the signature element of a declaration following the Annex IA/IB/VII layouts of the WSR. Note: This text may be auto-generated from an actual electronic signature by the software generating the message.	<a href="#">DeclarationType</a> / Signature
Movement Annex IB	15	Declaration	Generator-Producer name	normalizedString	256	Declaration Producer Name	The name provided under the declaration. Note: This is text intended to be printed/displayed at the name element of a declaration following the Annex IA/IB/VII layouts of the WSR.	<a href="#">DeclarationType</a> / Name
Movement Annex IB	15	Declaration	Generator-Producer date	date		Declaration Producer Date	The date of the declaration.	<a href="#">DeclarationType</a> / Date
Movement Annex IB	15	Declaration	Generator-Producer signature	string	256	Declaration Producer Signature Text	Text to be printed/displayed at the signature element of a declaration following the Annex IA/IB/VII layouts of the WSR. Note: This text may be auto-generated from an actual electronic signature by the software generating the message.	<a href="#">DeclarationType</a> / Signature
Movement Annex IB	16	Additional Information	Information	string	1024	Description	Additional information on the shipment of waste. Note: Corresponds to block 16 of Annex IB WSR.	<a href="#">TransportAnnouncementType</a> / AdditionalInformation

Movement Annex IB	17	Shipment recieved by (if not facility)	Declaratio n name	normalizedString	256	Declaration Name	The name provided under the declaration. Note: This is text intended to be printed/displayed at the name element of a declaration following the Annex IA/IB/VII layouts of the WSR.	<a href="#">DeclarationType</a> / Name
Movement Annex IB	17	Shipment recieved by (if not facility)	Declaratio n date	date		Declaration Date	The date of the declaration.	<a href="#">DeclarationType</a> / Date
Movement Annex IB	17	Shipment recieved by (if not facility)	Declaratio n signature	string	256	Declaration Signature Text	Text to be printed/displayed at the signature element of a declaration following the Annex IA/IB/VII layouts of the WSR. Note: This text may be auto-generated from an actual electronic signature by the software generating the message.	<a href="#">DeclarationType</a> / Signature
Movement Annex IB	18	Shipment received @ disposal / recovery facility	Disposal or recovery?				will be automatically derived from the recovery/disposal operations specified for that facility	

Movement Annex IB	18	Shipment received @ disposal / recovery facility	Accepted / Rejected	boolean		Rejection Indicator	An indication of whether or not the received waste is rejected by the recipient. Note: This indication is expected to be set to true for full rejection only. Partial rejection cannot be expressed with structured data in this data format, but rather needs to be described under RejectionDescription.	<a href="#">CertificateOfWasteReceiptType</a> / RejectionIndicator
Movement Annex IB	18	Shipment received @ disposal / recovery facility	Date of reception	date		Receipt Date	The date of waste receipt.	<a href="#">CertificateOfWasteReceiptType</a> / ReceiptDate
Movement Annex IB	18	Shipment received @ disposal / recovery facility	Tons	decimal	25	Mass Measurement Value	The mass of waste together with the unit of measurement, such as "t" for tonnes. Note: Within the EU the mass of waste must be specified with unit "t" for tonnes.	<a href="#">MassVolumeMeasureType</a> / MassMeasure
Movement Annex IB	18	Shipment received @ disposal / recovery facility	Tons	token	64	Mass Measurement Unit	The case sensitive (c/s) Unified Code for Units of Measure (UCUM) for this measurement. Example: "t" for tonnes, "kg" for kilograms, "m3" for cubic meters or "l" for liters.	<a href="#">MeasureType</a> / unitCode

Movement Annex IB	18	Shipment received @ disposal / recovery facility	m <sup>3</sup>	decimal	25	Volume Measurement Value	The volume of waste together with the unit of measurement, such as "m3" for cubic meters or "l" for liters. Note: Within the EU, only the mass of waste in tonnes ("t") is expected, whereas the volume of waste is not expected to be specified.	<a href="#">MassVolumeMeasureType</a> / VolumeMeasure
Movement Annex IB	18	Shipment received @ disposal / recovery facility	m <sup>3</sup>	token	64	Volume Mass Measurement Unit	The case sensitive (c/s) Unified Code for Units of Measure (UCUM) for this measurement. Example: "t" for tonnes, "kg" for kilograms, "m3" for cubic meters or "l" for liters.	<a href="#">MeasureType</a> / unitCode
Movement Annex IB	18	Shipment received @ disposal / recovery facility	Approximate date of disposal / recovery	date		Recovery Disposal Start Date	The approximate date of recovery or disposal.	<a href="#">CertificateOfWasteReceiptType</a> / RecoveryDisposalStartDate
Movement Annex IB	18	Shipment received @ disposal / recovery facility	D-code-R-code	token	D1-D15, R1-R13	Recovery Disposal Type Code	A code specifying the type of recovery or disposal conducted at the facility. Example: "R2" for "Solvent reclamation/regeneration".	<a href="#">CertificateOfWasteReceiptType</a> / RecoveryDisposalTypeCode

Movement Annex IB	19	Certificate of Completion	Declaration name	normalizedString	256	Declaration Name	The name provided under the declaration. Note: This is text intended to be printed/displayed at the name element of a declaration following the Annex IA/IB/VII layouts of the WSR.	<a href="#">DeclarationType</a> / Name
Movement Annex IB	19	Certificate of Completion	Declaration date	date		Declaration Date	The date of the declaration.	<a href="#">DeclarationType</a> / Date
Movement Annex IB	19	Certificate of Completion	Declaration signature	string	256	Declaration Signature Text	Text to be printed/displayed at the signature element of a declaration following the Annex IA/IB/VII layouts of the WSR. Note: This text may be auto-generated from an actual electronic signature by the software generating the message.	<a href="#">DeclarationType</a> / Signature
Movement Annex IB	20	Country of export/dispatch or customs of exit	Leaving Date	date		Date	The date of the declaration.	<a href="#">CustomsDeclarationType</a> / Date
Movement Annex IB	20	Country of export/dispatch or customs of exit	Signature / Stamp	string	256	Declaration Signature / Stamp	Text to be printed/displayed at the signature element of a declaration following the Annex IB layout of the WSR.	<a href="#">CustomsDeclarationType</a> / DeclarationSignatureText

Movement Annex IB	21	Country of import/destination or customs of entry	Entering Date	date		Date	The date of the declaration.	<a href="#">CustomsDeclarationType</a> / Date
Movement Annex IB	21	Country of import/destination or customs of entry	Signature / Stamp	string	256	Declaration Signature / Stamp	Text to be printed/displayed at the signature element of a declaration following the Annex IB layout of the WSR.	<a href="#">CustomsDeclarationType</a> / DeclarationSignatureText
Movement Annex IB	22	Stamps of customs offices of transit countries	Contry Name	string	3	Country ID	The ISO 3166-1 numeric 3 code specifying the country of the competent authority providing the acknowledgement.	<a href="#">TransitCustomsDeclarationType</a> / CountryID
Movement Annex IB	22	Stamps of customs offices of transit countries	Entering Date	date		Date	The date of the declaration.	<a href="#">CustomsDeclarationType</a> / Date
Movement Annex IB	22	Stamps of customs offices of transit countries	Entering Signature / Stamp	string	256	Declaration Signature / Stamp	Text to be printed/displayed at the signature element of a declaration following the Annex IB layout of the WSR.	<a href="#">CustomsDeclarationType</a> / DeclarationSignatureText

Movement Annex IB	22	Stamps of customs offices of transit countries	Leaving Date	date		Date	The date of the declaration.	<a href="#">CustomsDeclarationType</a> / Date
Movement Annex IB	22	Stamps of customs offices of transit countries	Leaving Signature / Stamp	string	256	Declaration Signature / Stamp	Text to be printed/displayed at the signature element of a declaration following the Annex IB layout of the WSR.	<a href="#">CustomsDeclarationType</a> / DeclarationSignatureText



## Annex VII Document

WSR document	WSR block no	WSR block name	WSR data element name	Type	Data type length	Data Element Name	Description	Reference
Annex VII	1	Person who arranges the shipment	Person arranging			see Exporter-Notifier Annex IB	The party arranging this shipment of waste. Note: Corresponds to block 1 of Annex VII WSR.	<a href="#">Annex7TransportAnnouncementType / Notifier</a>
Annex VII	2	Importer-Consignee				see Exporter-Notifier	The consignee of this shipment of waste. Note 2: Corresponds to block 2 of Annex VII WSR.	<a href="#">Annex7TransportAnnouncementType / Consignee</a>
Annex VII	3	Actual quantity	Tons	decimal	25	Mass Measurement Value	The mass of waste together with the unit of measurement, such as "t" for tonnes. Note: Within the EU the mass of waste must be specified with unit "t" for tonnes.	<a href="#">MassVolumeMeasureType / MassMeasure</a>
Annex VII	3	Actual quantity	Tons	token	64	Mass Measurement Unit	The case sensitive (c/s) Unified Code for Units of Measure (UCUM) for this measurement. Example: "t" for tonnes, "kg" for kilograms, "m3" for cubic meters or "l" for liters.	<a href="#">MeasureType / unitCode</a>

Annex VII	3	Actual quantity	m <sup>3</sup>	decimal	25	Volume Measurement Value	The volume of waste together with the unit of measurement, such as "m3" for cubic meters or "l" for liters. Note: Within the EU, only the mass of waste in tonnes ("t") is expected, whereas the volume of waste is not expected to be specified.	<a href="#">MassVolumeMeasureType / VolumeMeasure</a>
Annex VII	3	Actual quantity	m <sup>3</sup>	token	64	Volume Mass Measurement Unit	The case sensitive (c/s) Unified Code for Units of Measure (UCUM) for this measurement. Example: "t" for tonnes, "kg" for kilograms, "m3" for cubic meters or "l" for liters.	<a href="#">MassVolumeMeasureType / unitCode</a>
Annex VII	4	Actual shipment date	Shipment Date	date		Start Date	The start date of this shipment of waste. Note: Corresponds to block 4 of Annex VII WSR.	<a href="#">Annex7TransportAnnouncementType / StartDate</a>
Annex VII	5	Carriers				see Exporter-Notifier	Carriers conducting this shipment of waste. Note: Corresponds to block 5 of Annex VII WSR, without the parts to be completed by carriers (the latter are provided under Annex7Document/Transport).	<a href="#">Annex7TransportAnnouncementType / Carrier</a>

Annex VII	5	Carriers	Means of Transport	token	{A,R,S,T,W}	Transport Means Type Code	A code specifying the means of transport for this carrier. Example: "R" for road, "T" for train. Note: The WSR may define different codes in its various translations. In the electronic data interchange the codes from the English version of the regulation MUST be used, independent of the countries involved and independent of the language used in the document.	<a href="#">CarrierType</a> / MeansOfTransportCode
Annex VII	5	Transport				see Exporter-Notifier	Waste shipment information provided by carriers. Note: Corresponds to the parts of block 5 in Annex VII WSR to be completed by carriers.	<a href="#">Annex7DocumentType</a> / Transport
Annex VII	5	Transport	Means of Transport	token	{A,R,S,T,W}	Transport Means Type Code	A code specifying the means of transport for this carrier. Example: "R" for road, "T" for train. Note: The WSR may define different codes in its various translations. In the electronic data interchange the codes from the English version of the regulation MUST be used, independent of the countries involved and independent of the language used in the document.	<a href="#">CarrierType</a> / MeansOfTransportCode
Annex VII	5	Transport	Date of Transfer	date		Transfer Date	The date of waste transfer.	<a href="#">TransportType</a> / TransferDate

Annex VII	5	Transport	Signature	string	256	Carrier Signature Text	Text to be printed/displayed at the carrier's signature element in a layout following Annex IB or Annex VII of the WSR.	<a href="#">TransportType / CarrierSignatureText</a>
Annex VII	6	Waste Generator(s) - producer(s)				see Exporter-Notifier	Producers of the shipped waste. Note: Corresponds to block 6 of Annex VII WSR.	<a href="#">Annex7TransportAnnouncementType / WasteProducer</a>
Annex VII	7	Recovery Facility or Laboratory	Facility or Laboratory	boolean		Recovery Disposal Facility Indicator	An indication of whether the facility is a recovery facility (true) or a laboratory (false). Note 1: The details of the facility or laboratory are provided in the RecoveryDisposalFacility element. Note 2: Corresponds to the recovery facility / laboratory choice in block 7 of Annex VII WSR.	<a href="#">Annex7TransportAnnouncementType / RecoveryDisposalFacilityIndicator</a>
Annex VII	7	Recovery Facility or Laboratory				see Exporter-Notifier	ID, name, address and contact person of the recovery facility or laboratory. Note: Corresponds to blocks 7 and 8 of Annex VII WSR.	<a href="#">Annex7TransportAnnouncementType / RecoveryDisposalFacility</a>
Annex VII	8	Disposal / Recovery operation(s)	D-code-R-code	token	D1-D15, R1-R13	Recovery Disposal Type Code	A code specifying the type of recovery or disposal conducted at the facility. Example: "R2" for "Solvent reclamation/regeneration".	<a href="#">RecoveryDisposalFacilityType / RecoveryDisposalTypeCode</a>

Annex VII	9	Designation and composition of wastes	Waste Designation	string	1024	WasteDesignationDescription	Designation of the shipped waste. Note: Corresponds to block 9 of Annex VII WSR.	<a href="#">Annex7TransportAnnouncementType</a> / WasteDesignationDescription
Annex VII	10	Waste identification	(i-xii) waste identification codes	token	64	Waste Code Type	A code specifying a type of waste, in combination with a listID or listName attribute specifying the list from which the waste type code is taken.	<a href="#">WasteClassificationType</a> / WasteCodeType
Annex VII	10	Waste identification		token	{BASEL,CUST,EWL,HCODE,IWIC,NATEXP,NATIMP,OECD,OTHER,UNCLASS,UNNUM,UNSHIP,YCODE,ANNEX3A,ANNEX3B}	WasteCodeType / listID	The code specifying the waste list. Example: "EWL" for European Waste List. Note: Instead of referencing one of the enumerated waste lists such as European Waste List this can alternatively be set to a country code for a national waste classification.	<a href="#">WasteCodeType</a> / listID
Annex VII	11	Countries concerned	Country Code	string	3	Country ID	The ISO 3166-1 numeric 3 code specifying the country.	<a href="#">Annex7ConcernedCountryType</a> / CountryID
Annex VII	11	Countries concerned	Country Role	token	{I,E,T}	Country Role ID	The code specifying the role of this country. Options: "E" for "export", "I" for "import", "T" for "transit".	<a href="#">Annex7ConcernedCountryType</a> / CountryRoleID

Annex VII	12	Declaration	Person arranging name	normalizedString	256	Declaration Person arranging Name	The name provided under the declaration. Note: This is text intended to be printed/displayed at the name element of a declaration following the Annex IA/IB/VII layouts of the WSR.	<a href="#">DeclarationType</a> / Name
Annex VII	12	Declaration	Person arranging date	date		Declaration Person arranging Date	The date of the declaration.	<a href="#">DeclarationType</a> / Date
Annex VII	12	Declaration	Person arranging signature	string	256	Declaration Person arranging Signature Text	Text to be printed/displayed at the signature element of a declaration following the Annex IA/IB/VII layouts of the WSR. Note: This text may be auto-generated from an actual electronic signature by the software generating the message.	<a href="#">DeclarationType</a> / Signature
Annex VII	13	Shipment recieved by Consignee	Declaratio n name	normalizedString	256	Declaration Name	The name provided under the declaration. Note: This is text intended to be printed/displayed at the name element of a declaration following the Annex IA/IB/VII layouts of the WSR.	<a href="#">DeclarationType</a> / Name
Annex VII	13	Shipment recieved by Consignee	Declaratio n date	date		Declaration Date	The date of the declaration.	<a href="#">DeclarationType</a> / Date

Annex VII	13	Shipment received by Consignee	Declaration signature	string	256	Declaration Signature Text	Text to be printed/displayed at the signature element of a declaration following the Annex IA/IB/VII layouts of the WSR. Note: This text may be auto-generated from an actual electronic signature by the software generating the message.	<a href="#">DeclarationType</a> / Signature
Annex VII	14	Shipment received @ facility / laboratory	Facility or Laboratory?				will be automatically derived from block 7 'Recovery Disposal Facility Indicator'	
Annex VII	14	Shipment received @ facility / laboratory	Tons	decimal	25	Mass Measurement Value	The mass of waste together with the unit of measurement, such as "t" for tonnes. Note: Within the EU the mass of waste must be specified with unit "t" for tonnes.	<a href="#">MassVolumeMeasureType</a> / MassMeasure
Annex VII	14	Shipment received @ facility / laboratory	Tons	token	64	Mass Measurement Unit	The case sensitive (c/s) Unified Code for Units of Measure (UCUM) for this measurement. Example: "t" for tonnes, "kg" for kilograms, "m3" for cubic meters or "l" for liters.	<a href="#">MeasureType</a> / unitCode

Annex VII	14	Shipment received @ facility / laboratory	m <sup>3</sup>	decimal	25	Volume Measurement Value	The volume of waste together with the unit of measurement, such as "m3" for cubic meters or "l" for liters. Note: Within the EU, only the mass of waste in tonnes ("t") is expected, whereas the volume of waste is not expected to be specified.	<a href="#">MassVolumeMeasureType</a> / VolumeMeasure
Annex VII	14	Shipment received @ facility / laboratory	m <sup>3</sup>	token	64	Volume Mass Measurement Unit	The case sensitive (c/s) Unified Code for Units of Measure (UCUM) for this measurement. Example: "t" for tonnes, "kg" for kilograms, "m3" for cubic meters or "l" for liters.	<a href="#">MeasureType</a> / unitCode
Annex VII	14	Shipment received @ facility / laboratory	Declaration name	normalizedString	256	Declaration Name	The name provided under the declaration. Note: This is text intended to be printed/displayed at the name element of a declaration following the Annex IA/IB/VII layouts of the WSR.	<a href="#">DeclarationType</a> / Name
Annex VII	14	Shipment received @ facility / laboratory	Declaration date	date		Declaration Date	The date of the declaration.	<a href="#">DeclarationType</a> / Date



Annex VII	14	Shipment received @ facility / laboratory	Declaration signature	string	256	Declaration Signature Text	Text to be printed/displayed at the signature element of a declaration following the Annex IA/IB/VII layouts of the WSR. Note: This text may be auto-generated from an actual electronic signature by the software generating the message.	<a href="#">DeclarationType</a> / Signature
-----------	----	---	-----------------------	--------	-----	----------------------------	---	---

## Annex 2: Schema Structure and Description

### Contents

Complex content types.....	91
MessageType.....	91
AcknowledgementType.....	94
AddressType.....	95
Annex7ConcernedCountryType.....	96
Annex7DocumentType.....	96
Annex7TransportAnnouncementType.....	97
AnyXMLType.....	98
BinaryAttachmentType.....	99
CarrierType.....	99
CertificateOfCompletionType.....	100
CertificateOfWasteReceiptType.....	101
CommunicationType.....	103
CompetentAuthorityType.....	104
ConcernedCountryType.....	104
ContactType.....	105
CustomsDeclarationType.....	105
DecisionType.....	106
DeclarationType.....	108
DescriptionType.....	108
ExportStateType.....	109
ImportStateType.....	109
MassVolumeMeasureType.....	110
MovementPackagingType.....	110
NotificationDocumentType.....	111
NotificationMassVolumeMeasureType.....	112
PackagingType.....	113
PartyType.....	114
PersonType.....	116
RecoveryDisposalFacilityType.....	117
ShipmentPeriodType.....	118

StatementDocumentType .....	119
StatementType .....	120
SubmissionType.....	121
TransitCustomsDeclarationType .....	124
TransitStateType.....	125
TransportAnnouncementType .....	126
TransportType .....	129
VendorType .....	130
WasteClassificationType.....	130
WasteMovementDocumentType.....	131
WasteProducerType .....	133
Simple content types.....	133
BinaryAttachmentClassificationCodeType .....	133
BinaryObject.....	134
CountryCodeType.....	134
CountryRoleIDType .....	134
Decimal25Fraction5Type.....	135
GenderCodeType.....	135
LanguageDescriptionType .....	135
LanguageIdentifierType.....	135
MeansOfTransportCodeType .....	135
MeasureType.....	136
MessageCategoryCodeType .....	136
NameType .....	136
NonNegativeInteger8.....	136
NormalizedString.....	136
NotificationIdentifierType .....	137
PackageCodeType.....	137
PartyIdentificationSchemeIdentifierType .....	137
PartyIdentificationSchemeOrCountryIdentifierType .....	137
PartyIdentifierType.....	138
PersonNameType .....	138
PhoneType.....	138
PhysicalCharacteristicCodeType.....	138
PositiveInteger8.....	138

PriorityCodeType .....	139
RecoveryDisposalCodeType .....	139
RejectionIndicatorType .....	139
SiteldentificationSchemeldentifierType.....	139
SiteldentifierType .....	139
StatementTypeCodeType .....	140
String .....	140
String1024 .....	140
String256 .....	140
Token .....	140
Token64 .....	140
Token64OrEmpty.....	141
URIType .....	141
UuidType .....	141
WasteClassificationSchemeldentifierType.....	141
WasteClassificationSchemeOrCountryIdentifierType .....	141
WasteCodeType .....	142

The Schema Structure and Description contains all types defined in the XML Schema Definition (XSD) which make up the structure definition of every possible XML instance. It is meant as a reference document to look up the desired information.

As the message type (MessageType) is the starting point for every message specified, it is described at the beginning of Annex2. Annex 2 provides two lists of types sorted alphabetically, a list of complex content types and a list of simple content types; the complex content types are the key types for understanding the XSD.

For easier navigation through the hierarchical structure of the XSD, all types are connected by hyperlinks.

Annex 2 has been generated automatically from the XSD files.

# Complex content types

## MessageType

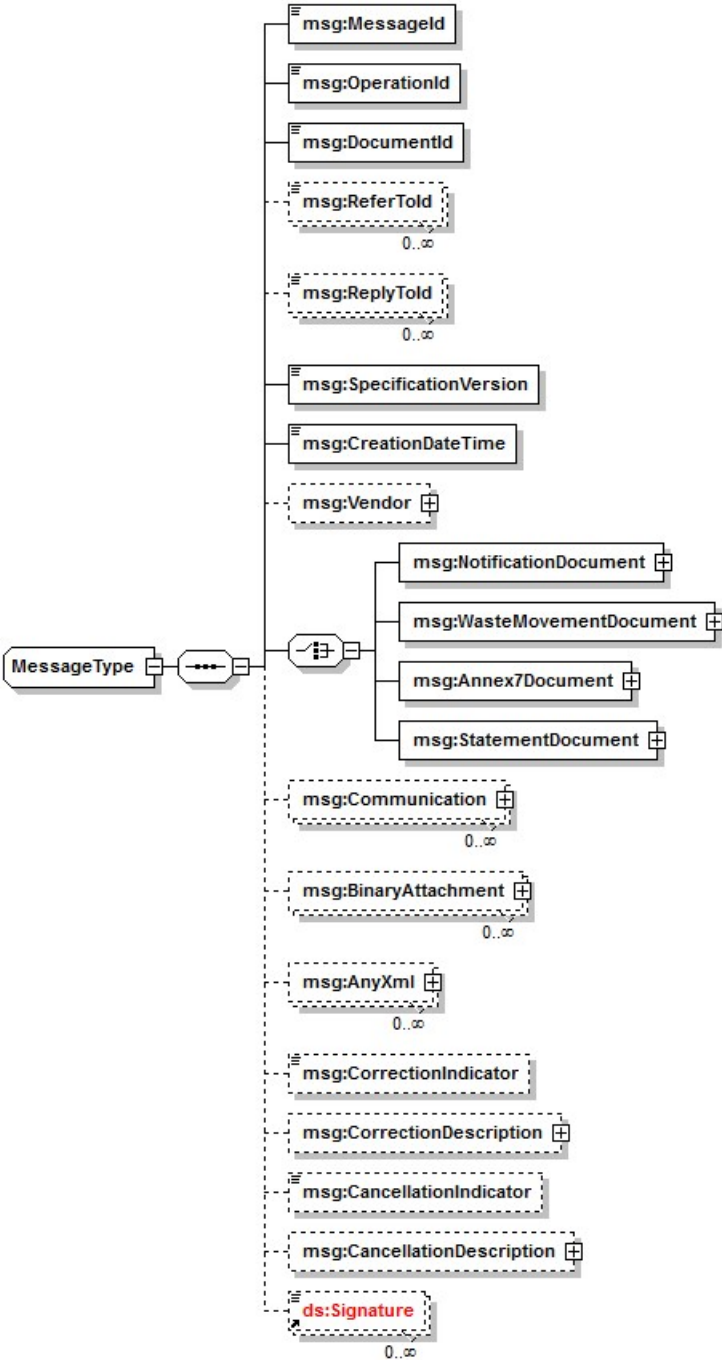

Message structure for Waste Shipments Regulation (WSR) related content, comprising generic information such as message ID and creation date on the one hand, and message type specific information, such as movement document content, on the other hand.

Name/Type	min..max	Definition
MessageId <a href="#">UuidType (p.141)</a>	1..1	UUID (Universally Unique ID) identifying the message, automatically assigned to the message by the software instance with which the message is created.

<b>OperationId</b> <a href="#">UuidType (p.141)</a>	1..1	<p>UUID (Universally Unique ID) identifying the operation to which this message belongs.</p> <p>Note 1: For shipments of waste under the "prior written notification and consent" procedure all notification document messages and movement document messages belonging to the same notification share the same OperationId.</p> <p>Note 2: This ID is typically automatically assigned to an operation by the software instance with which the first message under an operation, such as the Notification Submission message, is created.</p>
<b>DocumentId</b> <a href="#">UuidType (p.141)</a>	1..1	<p>UUID (Universally Unique ID) identifying the document.</p> <p>Note: Under the "prior written notification and consent" procedure there are two types of documents: Notification document and movement document.</p> <p>Example: "Written confirmation of receipt of the waste by the facility" does not introduce a new document, but rather extends an existing movement document. A message sent to confirm receipt of waste by the facility therefore does not introduce a new DocumentId, but rather includes the DocumentId of the existing movement document.</p> <p>Note: This ID is typically automatically assigned to a document by the software instance with which the first message belonging to a document, such as the Transport Announcement message, is created.</p>
<b>ReferTold</b> <a href="#">UuidType (p.141)</a>	0..*	<p>Reference to other messages upon which the current message is based, in the sense that content from these other messages has been copied into the current message.</p> <p>Note 1: The values in ReferTold have to match with MessageID values of previous messages.</p> <p>Note 2: DocumentId and OperationId must be identical in all messages linked to each other via ReferTold.</p> <p>Example 1: The first time a movement document is exchanged is at transport announcement (prior information regarding actual start of shipment). In this case, no content is copied from previous messages and ReferTold is omitted.</p> <p>Example 2: In a scenario where two carriers have contributed content to a movement document independent of each other (both messages referring to the transport announcement message), the message "confirming receipt of the waste by the facility" has to incorporate content from the two messages sent by carriers. Therefore two ReferTold elements are provided.</p>
<b>ReplyTold</b> <a href="#">UuidType (p.141)</a>	0..*	Reference to a statement
<b>SpecificationVersion</b> <a href="#">Token64 (p.140)</a>	1..1	<p>The latest version of the message specification supported by the software with which the message is generated.</p> <p>Example: "1.0"</p>
<b>CreationDateTime</b> <a href="#">dateTime</a>	1..1	<p>Date and time of message creation.</p> <p>Note: As with other header content, this element is expected to be automatically filled by the software with which the message is generated.</p>

Vendor <a href="#">VendorType (p.130)</a>	0..1	Information on the software with which the message was generated and its vendor. Note: This information is meant to provide clues to IT staff on solving issues with messages which cannot be processed, such as malformed messages.
NotificationDocument <a href="#">NotificationDocumentType (p.111)</a>	0..1	Details on a notification document as defined in Annex IA WSR.
WasteMovementDocument <a href="#">WasteMovementDocumentType (p.131)</a>	0..1	Details on a movement document as defined in Annex IB WSR.
Annex7Document <a href="#">Annex7DocumentType (p.96)</a>	0..1	Details on consignment information as defined in Annex VII WSR.
StatementDocument <a href="#">StatementDocumentType (p.119)</a>	0..1	A statement for exchanging information or issuing requests.
Communication <a href="#">CommunicationType (p.103)</a>	0..*	A list of recipients together with communication protocol information used for submitting messages to these recipients. Note: Whether or not communication protocol information is required depends on the specific communication infrastructure used for exchanging messages.
BinaryAttachment <a href="#">BinaryAttachmentType (p.99)</a>	0..*	Binary attachments to this message. Example: A notification submission may be accompanied by a PDF containing evidence of a financial guarantee or equivalent insurance, provided as binary attachment.
AnyXml <a href="#">AnyXMLType (p.98)</a>	0..*	Via the AnyXml element data not covered by the specification can be included in an XML message instance. Note: Each included AnyXml element must contain a distinct root node, a namespace URI to prevent name conflicts and a unique ID.
CorrectionIndicator <a href="#">boolean</a>	0..1	An indication of whether or not this message is a correction to a previous message. Note 1: A correction message must contain its own unique identifier under MessageId. It must not share the same identifier with the original message or with previous corrections. Note 2: A correction message is expected to contain the full document content, both content newly changed or appended, as well as unchanged content. Note 3: An omitted CorrectionIndicator element is equivalent to a CorrectionIndicator element set to false.
CorrectionDescription <a href="#">DescriptionType (p.108)</a>	0..1	A description of the correction and its reasons. Note: A CorrectionDescription element may be only provided in combination with CorrectionIndicator set to true.

<b>CancellationIndicator</b> <a href="#">boolean</a>	0..1	An indication of whether or not this message is supposed to cancel a previously created message. Note 1: A cancelled message (document) must not be corrected. Note 2: A cancellation applies to the whole document rather than a single message pertaining to a document. Note 3: An omitted CancellationIndicator element is equivalent to a CancellationIndicator set to false. Note 4: A cancellation message must contain the latest document content. Note 5: Correction and cancellation must not be combined within a message.
<b>CancellationDescription</b> <a href="#">DescriptionType (p.108)</a>	0..1	A description of the cancellation and its reasons. Note: A CancellationDescription element may only be provided in combination with a CancellationIndicator set to true.
<b>ds:Signature</b> <a href="#">ds:Signature</a>	0..*	Electronic seals and/or signatures in accordance with the EU eIDAS regulation, and thus compliant with XAdES Baseline Signatures B-B.

## AcknowledgementType

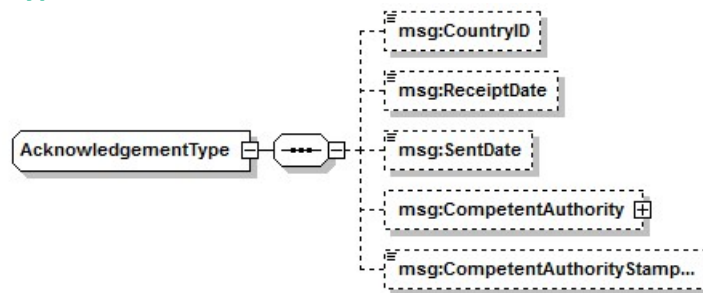

Details on a competent authority's acknowledgement of the receipt of a properly completed notification.

Name/Type	min..max	Definition
<b>CountryID</b> <a href="#">CountryCodeType (p.134)</a>	0..1	The ISO 3166-1 numeric 3 code specifying the country of the competent authority providing the acknowledgement.
<b>ReceiptDate</b> <a href="#">date</a>	0..1	The date at which the competent authority received the notification submission.
<b>SentDate</b> <a href="#">date</a>	0..1	The date at which the competent authority sent the acknowledgement.
<b>CompetentAuthority</b> <a href="#">CompetentAuthorityType (p.104)</a>	0..1	The competent authority acknowledging the receipt of a properly completed notification.
<b>CompetentAuthorityStampSignature</b> <a href="#">String256 (p.140)</a>	0..1	Text to be printed/displayed at the competent authority's stamp and signature element in a layout following Annex IA of the WSR.

AcknowledgementType is used in: [NotificationDocumentType \(p.111\)](#)



## AddressType



Details on an address, such as city name, street name, and building number.

Name/Type	min..max	Definition
CountryID <a href="#">CountryCodeType</a> (p.134)	0..1	The ISO 3166-1 numeric 3 code specifying the country of this address.
Postcode <a href="#">Token</a> (p.140)	0..1	The post code. Note: The post code is expected to not include a country identifier.
CityName <a href="#">Token</a> (p.140)	0..1	The city name (name of a city, town or village).
StreetName <a href="#">Token</a> (p.140)	0..1	The street name.
BuildingNumber <a href="#">Token</a> (p.140)	0..1	The building number.
CitySubDivisionName <a href="#">Token</a> (p.140)	0..1	The city sub-division name, such as the name of a district or borough. Note: City sub-division names are relatively uncommon in addresses.
BlockName <a href="#">Token</a> (p.140)	0..1	The block name. Note 1: A block is an area surrounded by streets and usually containing several buildings. Note 2: In Europe, block names are relatively uncommon in addresses.
PostOfficeBox <a href="#">Token</a> (p.140)	0..1	The post office box identifier. Note: Post office box addresses may be acceptable for addresses such as head office addresses, but must not be used for addresses which need to be locatable, such as site addresses.

StaircaseNumber <a href="#">Token (p.140)</a>	0..1	The staircase number.
FloorIdentification <a href="#">Token (p.140)</a>	0..1	The floor number or identifier.
RoomIdentification <a href="#">Token (p.140)</a>	0..1	The room number or identifier (identification of a room, suite, office, apartment, etc.).

AddressType is used in: [PartyType \(p.114\)](#)

## Annex7ConcernedCountryType

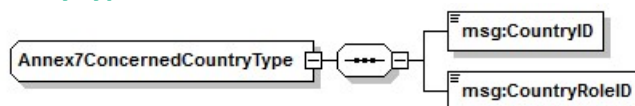

Details on the countries involved in a shipment of waste.

Name/Type	min..max	Definition
CountryID <a href="#">CountryCodeType (p.134)</a>	1..1	The ISO 3166-1 numeric 3 code specifying the country.
CountryRoleID <a href="#">CountryRoleIDType (p.134)</a>	1..1	The code specifying the role of this country. Options: "E" for "export", "I" for "import", "T" for "transit".

Annex7ConcernedCountryType is used in: [Annex7TransportAnnouncementType \(p.97\)](#)

## Annex7DocumentType

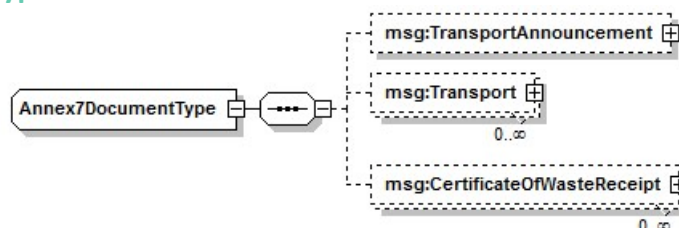

Consignment information as defined in Annex VII WSR.

Name/Type	min..max	Definition
TransportAnnouncement <a href="#">Annex7TransportAnnouncementType (p.97)</a>	0..1	Information on a shipment of waste provided by the person who arranges the shipment. Note: Corresponds to blocks 1 to 12 of Annex VII WSR, with the exception of the parts of block 5 to be completed by carriers.
Transport <a href="#">TransportType (p.129)</a>	0..*	Waste shipment information provided by carriers. Note: Corresponds to the parts of block 5 in Annex VII WSR to be completed by carriers.
CertificateOfWasteReceipt <a href="#">CertificateOfWasteReceiptType (p.101)</a>	0..*	Waste receipt related information typically provided by a recovery or disposal facility or a laboratory. Note: Corresponds to blocks 13 and 14 of Annex VII WSR.

Annex7DocumentType is used in: [MessageType \(p.91\)](#)

## Annex7TransportAnnouncementType



Details on an individual shipment of waste (as referred to in Article 3(2) and (4) WSR).

Name/Type	min..max	Definition
Notifier <a href="#">PartyType (p.114)</a>	0..1	The party arranging this shipment of waste. Note: Corresponds to block 1 of Annex VII WSR.
Consignee <a href="#">PartyType (p.114)</a>	0..1	The consignee of this shipment of waste. Note 2: Corresponds to block 2 of Annex VII WSR.
ActualQuantity <a href="#">MassVolumeMeasureType (p.110)</a>	0..1	The actual quantity of waste to be shipped. Note: Corresponds to block 3 of Annex VII WSR.
StartDate <a href="#">date</a>	0..1	The start date of this shipment of waste. Note: Corresponds to block 4 of Annex VII WSR.
Carrier <a href="#">CarrierType (p.99)</a>	0..*	Carriers conducting this shipment of waste. Note 1: Corresponds to block 5 of Annex VII WSR, without the parts to be completed by carriers (the latter are provided under Annex7Document/Transport). Note 2: If there are more than three Carrier element instances within a message, this corresponds to an “attached list”, whereby the order of Carrier element instances reflects the order of the attached list.

WasteProducer <a href="#">PartyType (p.114)</a>	0..*	Producers of the shipped waste. Note 1: Corresponds to block 6 of Annex VII WSR. Note 2: If there are two or more WasteProducer element instances within a message, this corresponds to an “attached list”, whereby the order of WasteProducer element instances in the message is open.
RecoveryDisposalFacilityIndicator <a href="#">boolean</a>	0..1	An indication of whether the facility is a recovery facility (true) or a laboratory (false). Note 1: The details of the facility or laboratory are provided in the RecoveryDisposalFacility element. Note 2: Corresponds to the recovery facility / laboratory choice in block 7 of Annex VII WSR.
RecoveryDisposalFacility <a href="#">RecoveryDisposalFacilityType (p.117)</a>	0..1	ID, name, address and contact person of the recovery facility or laboratory. Note: Corresponds to blocks 7 and 8 of Annex VII WSR.
WasteDesignationDescription <a href="#">DescriptionType (p.108)</a>	0..1	Designation of the shipped waste. Note: Corresponds to block 9 of Annex VII WSR.
WasteClassification <a href="#">WasteClassificationType (p.130)</a>	0..1	Classification of the shipped waste. Note: Corresponds to block 10 of Annex VII WSR.
ConcernedCountry <a href="#">Annex7ConcernedCountryType (p.96)</a>	0..*	Countries concerned by this shipment of waste (dispatch, transit, destination). Note: Corresponds to block 11 of Annex VII WSR.
DeclarationExporter <a href="#">DeclarationType (p.108)</a>	0..1	Declaration of the person who arranges the shipment. Note: Corresponds to block 12 of Annex VII WSR.

Annex7TransportAnnouncementType is used in: [Annex7DocumentType \(p.96\)](#)

## AnyXMLType

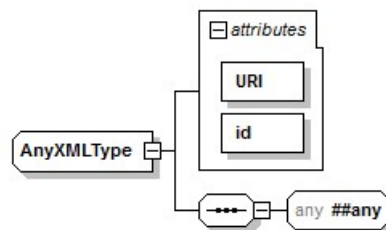

Arbitrary XML content.

Name/Type	min..max	Definition
-----------	----------	------------

AnyXMLType is used in: [MessageType \(p.91\)](#)

## BinaryAttachmentType

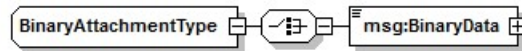

Details on a binary attachment.

Name/Type	min..max	Definition
BinaryData <a href="#">BinaryObject (p.134)</a>	0..1	The base64 representation of the binary attachment.

BinaryAttachmentType is used in: [MessageType \(p.91\)](#)

## CarrierType

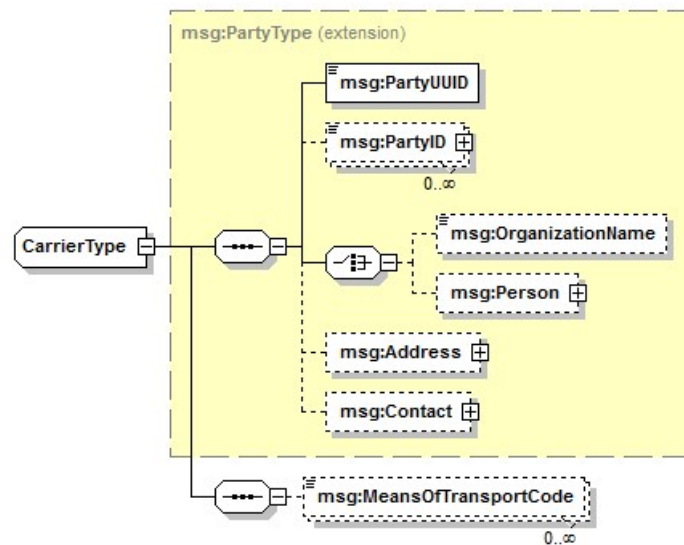

Details on a carrier.

Name/Type	min..max	Definition
MeansOfTransportCode <a href="#">MeansOfTransportCodeType (p.135)</a>	0..*	A code specifying the means of transport for this carrier. Example: "R" for road, "T" for train. Note: The WSR may define different codes in its various translations. In the electronic data interchange the codes from the English version of the regulation MUST be used, independent of the countries involved and independent of the language used in the document.

CarrierType is used in: [Annex7TransportAnnouncementType \(p.97\)](#), [SubmissionType \(p.121\)](#), [TransportAnnouncementType \(p.126\)](#)

### CertificateOfCompletionType

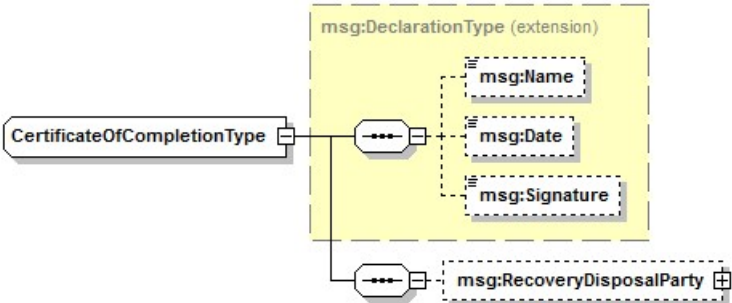

Details on the completion of waste recovery or disposal.

Name/Type	min..max	Definition
RecoveryDisposalParty <a href="#">PartyType (p.114)</a>	0..1	The party confirming the completion of a recovery or disposal operation.

CertificateOfCompletionType is used in: [WasteMovementDocumentType \(p.131\)](#)

### CertificateOfWasteReceiptType

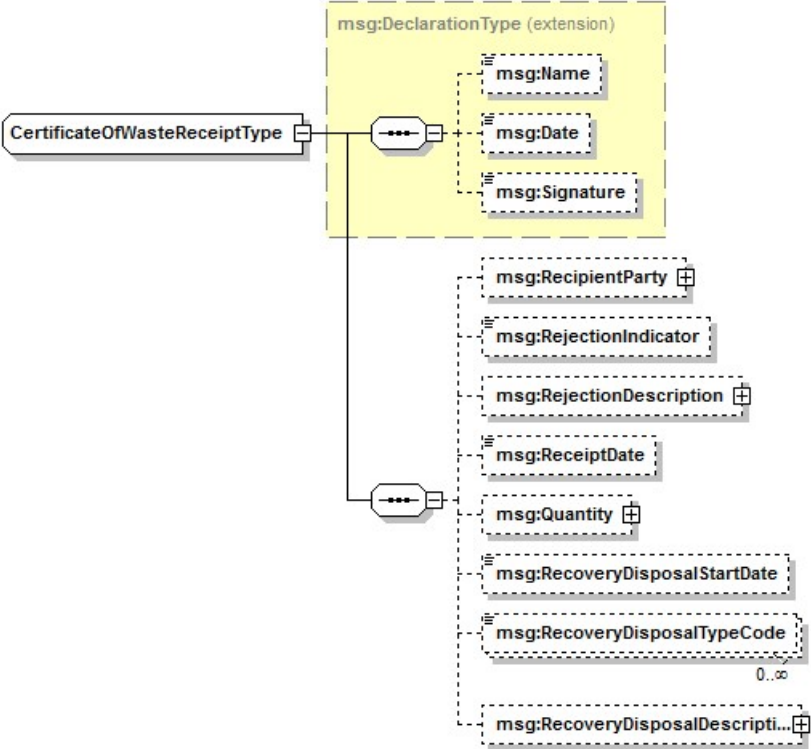

Details on the receipt of waste, such as date of receipt, recipient and amount of waste received.

Name/Type	min..max	Definition
RecipientParty <a href="#">PartyType (p.114)</a>	0..1	The party confirming the receipt of a shipment of waste.
RejectionIndicator <a href="#">boolean</a>	0..1	An indication of whether or not the received waste is rejected by the recipient. Note: This indication is expected to be set to true for full rejection only. Partial rejection cannot be expressed with structured data in this data format, but rather needs to be described under RejectionDescription.
RejectionDescription <a href="#">DescriptionType (p.108)</a>	0..1	Only filled in case of partial rejection. Note: The description will be needed in cases in which the waste was rejected partially.
ReceiptDate <a href="#">date</a>	0..1	The date of waste receipt.
Quantity <a href="#">MassVolumeMeasureType (p.110)</a>	0..1	The quantity of waste received.
RecoveryDisposalStartDate <a href="#">date</a>	0..1	The approximate date of recovery or disposal.
RecoveryDisposalTypeCode <a href="#">RecoveryDisposalCodeType (p.139)</a>	0..*	A code specifying the type of recovery or disposal conducted at the facility. Example: "R2" for "Solvent reclamation/regeneration".
RecoveryDisposalDescription <a href="#">DescriptionType (p.108)</a>	0..1	The description of the recovery or disposal operation. Note: A description may be provided in cases in which the recovery or disposal operation is not sufficiently described by the code in RecoveryDisposalTypeCode.

CertificateOfWasteReceiptType is used in: [Annex7DocumentType \(p.96\)](#), [WasteMovementDocumentType \(p.131\)](#)



## CommunicationType

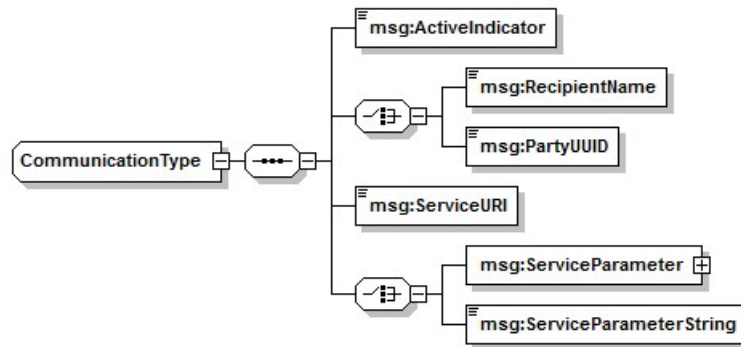

Details on electronic data interchange communication.

Name/Type	min..max	Definition
ActiveIndicator <a href="#">boolean</a>	1..1	An indication of whether or not the party should receive the message. Note: An ActiveIndicator set to false permits interchange of communication protocol information about a particular party without actually transmitting the message to this party.
RecipientName <a href="#">NameType (p.136)</a>	0..1	The recipient name.
PartyUUID <a href="#">UuidType (p.141)</a>	0..1	UUID (Universally Unique ID) identifying the recipient.
ServiceURI <a href="#">anyURI</a>	1..1	URI identifying the service by which the recipient can be reached.
ServiceParameter <a href="#">any</a>	0..1	Parameters to be used with the service when transmitting the message to the recipient. Note: The types of parameters to be provided depend on the type of service used to reach the recipient.
ServiceParameterString <a href="#">Token (p.140)</a>	0..1	A string containing parameter information to be passed to the service when transmitting the message to the recipient. Note: The types of parameters to be provided depend on the type of service used to reach the recipient.

CommunicationType is used in: [MessageType \(p.91\)](#)

## CompetentAuthorityType

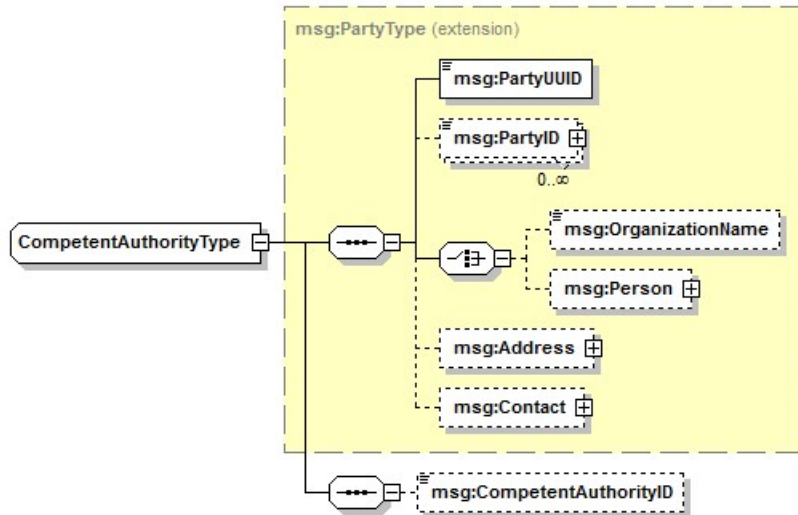

Details on a competent authority, such as name, address and contact.

Name/Type	min..max	Definition
CompetentAuthorityID <a href="#">Token64 (p.140)</a>	0..1	Competent authority identifier. Note: Where available, identifiers are taken from the following list: <a href="http://ec.europa.eu/environment/waste/shipments/pdf/list_competent_authorities.pdf">http://ec.europa.eu/environment/waste/shipments/pdf/list_competent_authorities.pdf</a>

CompetentAuthorityType is used in: [AcknowledgementType \(p.94\)](#), [ConcernedCountryType \(p.104\)](#), [DecisionType \(p.106\)](#)

## ConcernedCountryType

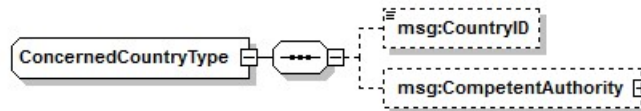

Details on the countries and competent authorities involved in a shipment of waste.

Name/Type	min..max	Definition
CountryID <a href="#">CountryCodeType (p.134)</a>	0..1	The ISO 3166-1 numeric 3 code specifying the country.
CompetentAuthority <a href="#">CompetentAuthorityType (p.104)</a>	0..1	The competent authority for shipment of waste under this notification in the specified country.

## ContactType

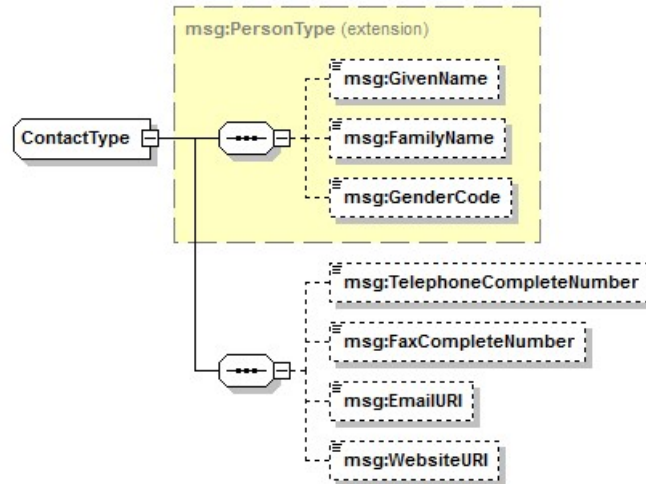

Details on a contact, such as contact person, telephone number and email address.

Name/Type	min..max	Definition
TelephoneCompleteNumber <a href="#">PhoneType (p.138)</a>	0..1	The complete contact phone number. Examples: +49 1 234 5678, 0049 1 234 5678
FaxCompleteNumber <a href="#">PhoneType (p.138)</a>	0..1	The complete contact fax number.
EmailURI <a href="#">URIType (p.141)</a>	0..1	The contact email address. Example: "office@example.com"
WebsiteURI <a href="#">URIType (p.141)</a>	0..1	The contact website. Example: "https://www.example.com"

ContactType is used in: [PartyType \(p.114\)](#)

## CustomsDeclarationType

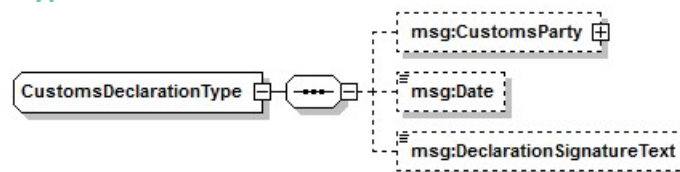

Details on a customs declaration.

Name/Type	min..max	Definition
CustomsParty <a href="#">PartyType (p.114)</a>	0..1	The customs office providing the declaration.
Date <a href="#">date</a>	0..1	The date of the declaration.
DeclarationSignatureText <a href="#">String256 (p.140)</a>	0..1	Text to be printed/displayed at the signature element of a declaration following the Annex IB layout of the WSR.

CustomsDeclarationType is used in: [TransitCustomsDeclarationType \(p.124\)](#), [WasteMovementDocumentType \(p.131\)](#)

# DecisionType

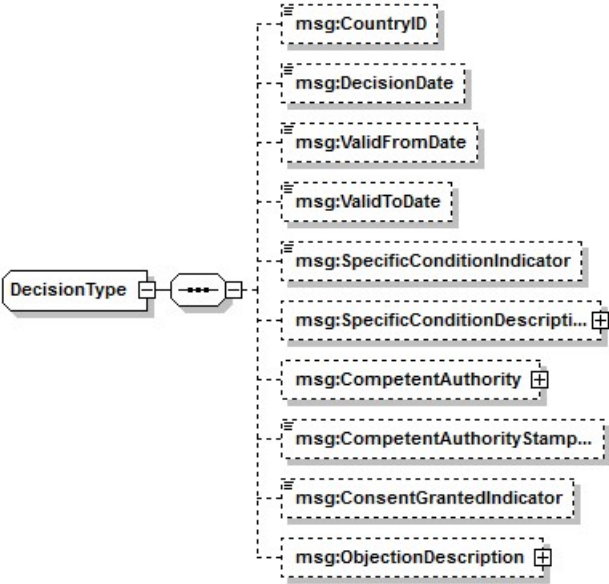

Details on a competent authority's decision on a notification (consent, consent with conditions or objection).

Name/Type	min..max	Definition
CountryID <a href="#">CountryCodeType (p.134)</a>	0..1	The ISO 3166-1 numeric 3 code specifying the country of the competent authority providing the decision.
DecisionDate <a href="#">date</a>	0..1	The date at which the competent authority decided over the notification.
ValidFromDate <a href="#">date</a>	0..1	The date from which the consent is valid. Note: This element must not be used with objections, i.e. it must not be used in combination with the ConsentGrantedIndicator set to false.
ValidToDate <a href="#">date</a>	0..1	The date up to which the consent is valid. Note: This element must not be used with objections, i.e. it must not be used in combination with the ConsentGrantedIndicator set to false.
SpecificConditionIndicator <a href="#">boolean</a>	0..1	The indication of whether or not there are specific conditions under which the consent is granted. Note: This element must not be used with objections, i.e. it must not be used in combination with the ConsentGrantedIndicator set to false.
SpecificConditionDescription <a href="#">DescriptionType (p.108)</a>	0..1	The description of the specific conditions under which the consent is granted. Note: The description of specific conditions is expected if and only if there is a SpecificConditionIndicator set to true.
CompetentAuthority <a href="#">CompetentAuthorityType (p.104)</a>	0..1	The competent authority expressing its consent or its objection with regard to notified shipments of waste.
CompetentAuthorityStampSignature <a href="#">String256 (p.140)</a>	0..1	Text to be printed/displayed at the competent authority's stamp and signature element in a layout following Annex IA of the WSR.
ConsentGrantedIndicator <a href="#">boolean</a>	0..1	An indication of whether or not the authority consents the notification. Note: A ConsentGrantedIndicator set to false indicates an authority's objection to the notified shipments of waste.
ObjectionDescription <a href="#">DescriptionType (p.108)</a>	0..1	The description and explanation of the competent authority's objection to the notified shipments of waste. Note: The objection description is expected if and only if there is a ConsentGrantedIndicator set to false.

DecisionType is used in: [NotificationDocumentType \(p.111\)](#)

## DeclarationType

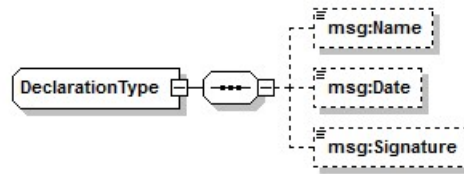

Details on a declaration, such as declarator's name and declaration date.

Name/Type	min..max	Definition
Name <a href="#">NameType</a> (p.136)	0..1	The name provided under the declaration. Note: This is text intended to be printed/displayed at the name element of a declaration following the Annex IA/IB/VII layouts of the WSR.
Date <a href="#">date</a>	0..1	The date of the declaration.
Signature <a href="#">String256</a> (p.140)	0..1	Text to be printed/displayed at the signature element of a declaration following the Annex IA/IB/VII layouts of the WSR. Note: This text may be auto-generated from an actual electronic signature by the software generating the message.

DeclarationType is used in: [Annex7TransportAnnouncementType](#) (p.97), [NotificationDocumentType](#) (p.111), [WasteMovementDocumentType](#) (p.131)

## DescriptionType

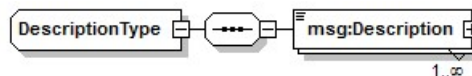

A textual description which may be provided in multiple languages.

Name/Type	min..max	Definition
Description <a href="#">LanguageDescriptionType</a> (p.135)	1..*	A textual description in a specific language, together with an ISO 639-1 language code in the languageID attribute.

DescriptionType is used in: [MessageType](#) (p.91), [Annex7TransportAnnouncementType](#) (p.97), [CertificateOfWasteReceiptType](#) (p.101), [DecisionType](#) (p.106), [PackagingType](#) (p.113), [RecoveryDisposalFacilityType](#) (p.117), [StatementType](#) (p.120), [SubmissionType](#) (p.121), [TransportAnnouncementType](#) (p.126), [WasteProducerType](#) (p.133)

## ExportStateType

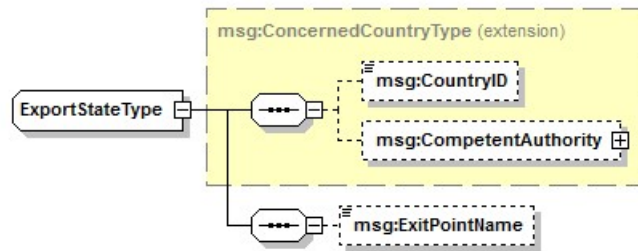

Details on the export state, such as competent authority and point of exit.

Name/Type	min..max	Definition
ExitPointName <a href="#">NameType (p.136)</a>	0..1	The name of the point of exit in the country of dispatch.

`ExportStateType` is used in: [SubmissionType \(p.121\)](#)

## ImportStateType

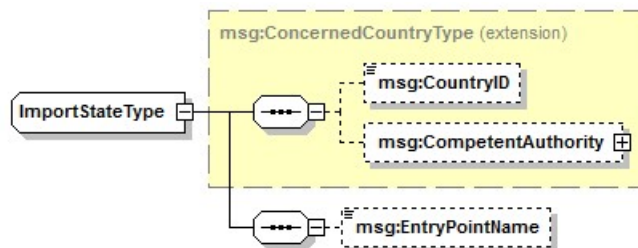

Details on the import state, such as competent authority and point of entry.

Name/Type	min..max	Definition
EntryPointName <a href="#">NameType (p.136)</a>	0..1	The name of the point of entry in the country of destination.

`ImportStateType` is used in: [SubmissionType \(p.121\)](#)

## MassVolumeMeasureType

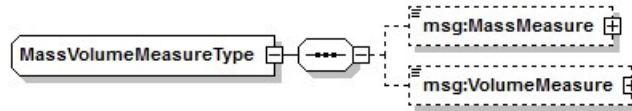

Mass and/or volume measures.

Name/Type	min..max	Definition
MassMeasure <a href="#">MeasureType (p.136)</a>	0..1	The mass of waste together with the unit of measurement, such as "t" for tonnes. Note: Within the EU the mass of waste must be specified with unit "t" for tonnes.
VolumeMeasure <a href="#">MeasureType (p.136)</a>	0..1	The volume of waste together with the unit of measurement, such as "m3" for cubic meters or "l" for liters. Note: Within the EU, only the mass of waste in tonnes ("t") is expected, whereas the volume of waste is not expected to be specified.

MassVolumeMeasureType is used in: [Annex7TransportAnnouncementType \(p.97\)](#), [CertificateOfWasteReceiptType \(p.101\)](#), [TransportAnnouncementType \(p.126\)](#)

## MovementPackagingType

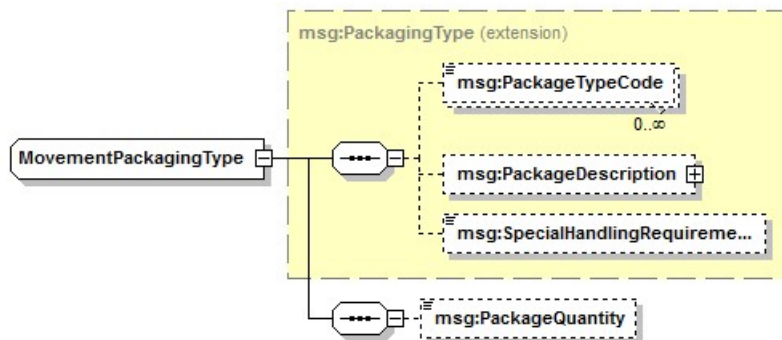

Details on the packaging of an individual shipment of waste.

Name/Type	min..max	Definition
PackageQuantity <a href="#">PositiveInteger8 (p.138)</a>	0..1	The number of packages in this shipment of waste.

MovementPackagingType is used in: [TransportAnnouncementType \(p.126\)](#)



## NotificationDocumentType

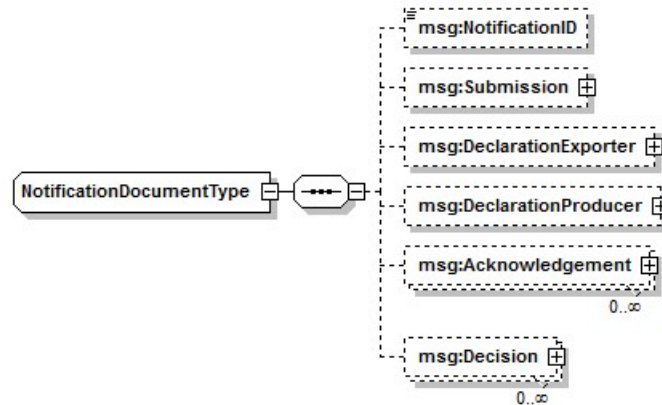

Details on a notification document as defined in Annex IA WSR.

Name/Type	min..max	Definition
NotificationID <a href="#">NotificationIdentifierType (p.137)</a>	0..1	The notification number assigned to the notification by the Competent Authority of Dispatch or an IT solution on its behalf. Example: "DE 030855" Note: By convention, the notification number is expected to start with the ISO 3166-1 alpha-2 country code, such as 'DE' or 'IT'.
Submission <a href="#">SubmissionType (p.121)</a>	0..1	Data submitted by the notifier to competent authorities. Note: Corresponds to blocks 1 to 18 of Annex IA WSR.
DeclarationExporter <a href="#">DeclarationType (p.108)</a>	0..1	Notifier's declaration. Note: Corresponding to block 17 of Annex IA WSR.
DeclarationProducer <a href="#">DeclarationType (p.108)</a>	0..1	Waste producer's declaration. Note: Corresponding to block 17 of Annex IA WSR.
Acknowledgement <a href="#">AcknowledgementType (p.94)</a>	0..*	A competent authority's (CA) acknowledgement of the receipt of a properly completed notification. Note 1: A separate Acknowledgement element is used for each CA's acknowledgement. Note 2: Corresponds to Article 8(2) and block 19 of Annex IA WSR.
Decision <a href="#">DecisionType (p.106)</a>	0..*	A competent authority's (CA) decision on a submitted notification: consent, consent with conditions or objection. Note 1: A separate Decision element is used for each CA's acknowledgement. Note 2: Corresponds to block 20 of Annex IA WSR, except for objection.

NotificationDocumentType is used in: [MessageType \(p.91\)](#)

## NotificationMassVolumeMeasureType

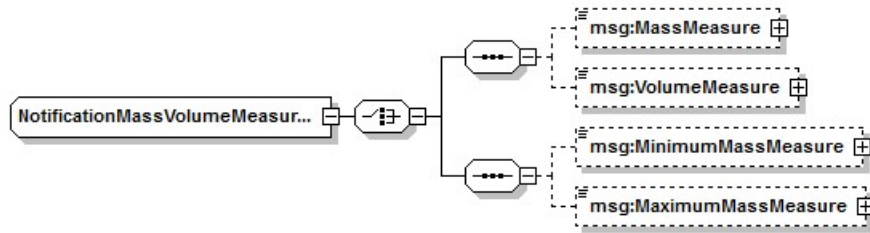

Details on the amount of waste intended to be shipped under one notification.

Name/Type	min..max	Definition
MassMeasure <a href="#">MeasureType (p.136)</a>	0..1	The mass of waste together with the unit of measurement, such as "t" for tonnes. Note: Within the EU the mass of waste must be specified with unit "t" for tonnes.
VolumeMeasure <a href="#">MeasureType (p.136)</a>	0..1	The volume of waste together with the unit of measurement, such as "m3" for cubic meters or "l" for liters. Note: Within the EU, only the mass of waste in tonnes ("t") is expected, whereas the volume of waste is not expected to be specified.
MinimumMassMeasure <a href="#">MeasureType (p.136)</a>	0..1	The minimum amount (mass) of waste intended to be shipped, expressed in tonnes ("t"). Note: Corresponds to Annex IC No. 17 of the WSR.
MaximumMassMeasure <a href="#">MeasureType (p.136)</a>	0..1	The maximum amount (mass) of waste intended to be shipped, expressed in tonnes ("t"). Note: Corresponds to Annex IC No. 17 of the WSR.

NotificationMassVolumeMeasureType is used in: [SubmissionType \(p.121\)](#)

## PackagingType

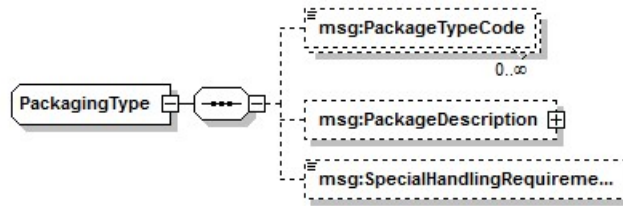

Details on packaging, such as packaging type and description.

Name/Type	min..max	Definition
PackageTypeCode <a href="#">PackageCodeType (p.137)</a>	0..*	A code specifying the type of package. Example: "6" for "composite packaging".
PackageDescription <a href="#">DescriptionType (p.108)</a>	0..1	Description of the type of packaging. Note: A description is expected if none of the packaging types 1 to 8 of Annex IA and Annex IB applies, and can also be provided in addition to packaging types 1 to 8.
SpecialHandlingRequirementIndicator <a href="#">boolean</a>	0..1	An indication of whether or not special handling is required for the packages.

PackagingType is used in: [SubmissionType \(p.121\)](#)

PartyType

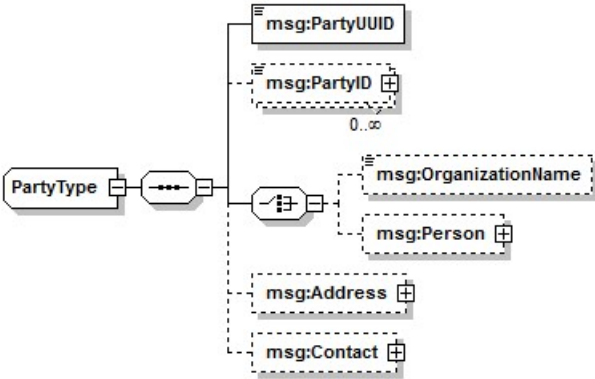

Details on a party (company, other type of legal person, or natural person), such as name, address and contact.

Name/Type	min..max	Definition
PartyUUID <a href="#">UuidType (p.141)</a>	1..1	<p>Universally Unique ID (UUID) automatically assigned by an IT system to a party (Notifier, Consignee, CompetentAuthority, ...).</p> <p>Note 1: In case of a waste producer or facility, every combination of a party and site must have a different UUID to distinguish the individual sites of the same waste producer or facility.</p> <p>Note 2: New UUIDs are assigned per operation, including for references to the same party.</p> <p>Example 1: For two notifications with the same notifier, a new notifier UUID is expected to be assigned in each of the notifications.</p> <p>Note 3: New UUIDs are assigned per party, including for references to the same party within one notification.</p> <p>Example 2: For a notification where the same party acts as consignee and recovery or disposal facility, the UUID assigned to the notification's consignee entry is expected to be different from the UUID assigned to the recovery or disposal facility entry.</p> <p>Example 3: For a notification where there are multiple production sites under the same waste producer party, each of the WasteProducer entries is expected to be assigned a unique UUID.</p> <p>Note 4: In subsequent messages under the same operation, the same party must have the same PartyUUID assigned.</p> <p>Example 4: In a WasteMovementDocument message, each party entry must carry the same UUID as the corresponding party entry in a previous Notification Document message.</p>
PartyID <a href="#">PartyIdentifierType (p.138)</a>	0..*	<p>Party identifiers (registration no) such as the VAT number (Value Added Tax) or GLN (Global Location Number).</p> <p>Note: For each classification scheme only one identifier is allowed.</p>
OrganizationName <a href="#">NameType (p.136)</a>	0..1	Party name for parties which are not natural persons.
Person <a href="#">PersonType (p.116)</a>	0..1	Name and optionally gender for parties who are natural persons.
Address <a href="#">AddressType (p.95)</a>	0..1	The party's (registered) head office address.
Contact <a href="#">ContactType (p.105)</a>	0..1	Contact information for this party, such as a contact person, a contact phone number or an email address.

PartyType is used in: [Annex7TransportAnnouncementType \(p.97\)](#), [CertificateOfCompletionType \(p.100\)](#), [CertificateOfWasteReceiptType \(p.101\)](#), [CustomsDeclarationType \(p.105\)](#), [SubmissionType \(p.121\)](#), [TransportAnnouncementType \(p.126\)](#)

## PersonType

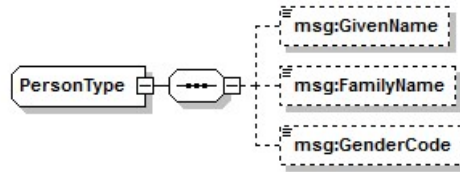

Details on a person, such as name and gender.

Name/Type	min..max	Definition
GivenName <a href="#">PersonNameType</a> <a href="#">(p.138)</a>	0..1	The person's given name.
FamilyName <a href="#">PersonNameType</a> <a href="#">(p.138)</a>	0..1	The person's family name.
GenderCode <a href="#">GenderCodeType</a> <a href="#">(p.135)</a>	0..1	The ISO 5218 code specifying the person's gender. Examples: "1" for male, "2" for female. Note: There is no requirement in the WSR to provide a person's gender. Despite the lack of such a requirement, on paper forms persons are often specified with a "Mr." or "Mrs." title indicating gender. In order to enable the same level of detail in structured electronic data, an optional gender element is included.

PersonType is used in: [PartyType](#) (p.114)

# RecoveryDisposalFacilityType

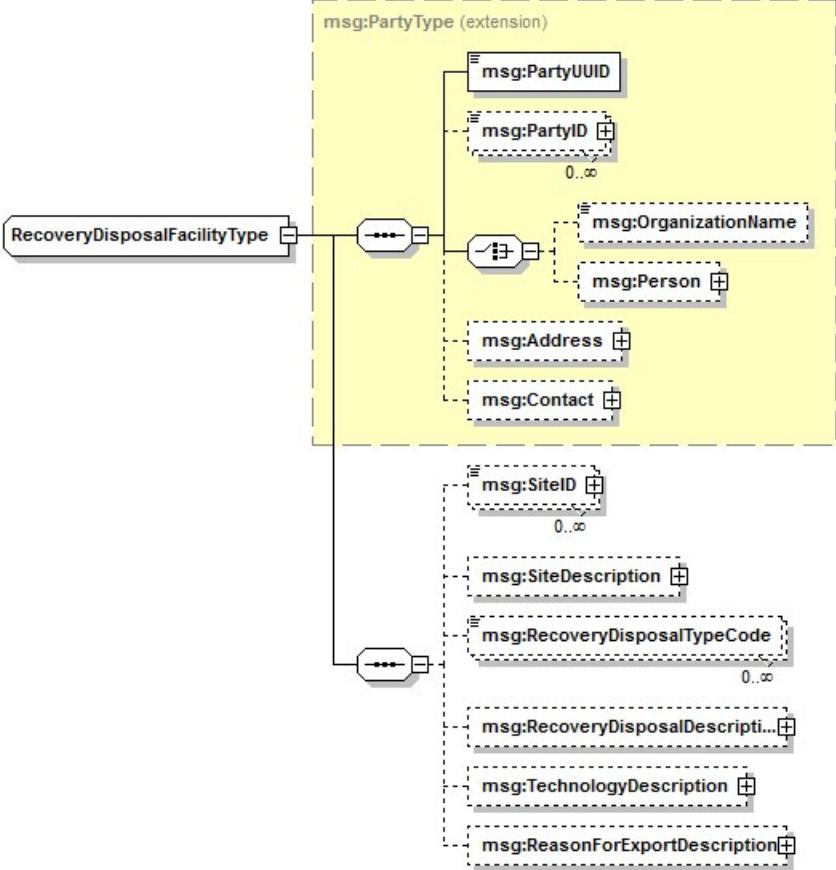

Details on a recovery or disposal process, such as facility (party), site and type of operation.

Name/Type	min..max	Definition
SiteID <a href="#">SiteIdentifierType (p.139)</a>	0..*	Site identifiers (registration no) such as the GLN (Global Location Number). Note: For each classification scheme only one identifier is allowed.
SiteDescription <a href="#">DescriptionType (p.108)</a>	0..1	The description of the site of disposal or recovery such as name and address.
RecoveryDisposalTypeCode <a href="#">RecoveryDisposalCodeType (p.139)</a>	0..*	A code specifying the type of recovery or disposal conducted at the facility. Example: "R2" for "Solvent reclamation/regeneration".
RecoveryDisposalDescription <a href="#">DescriptionType (p.108)</a>	0..1	The description of the recovery or disposal operation. Note: A description may be provided in cases in which the recovery or disposal operation is not sufficiently described by the code in RecoveryDisposalTypeCode.
TechnologyDescription <a href="#">DescriptionType (p.108)</a>	0..1	The description of the facility's recovery or disposal technology.
ReasonForExportDescription <a href="#">DescriptionType (p.108)</a>	0..1	The description of the reason for export to this facility where required by a competent authority outside the OECD. Duly motivated request from the country of dispatch in case of imports into the EU of wastes destined for disposal (Annex IA block 11 and Annex IC para. 22); Note: Binary attachments can provide further information in addition to this description

RecoveryDisposalFacilityType is used in: [Annex7TransportAnnouncementType \(p.97\)](#), [SubmissionType \(p.121\)](#), [TransportAnnouncementType \(p.126\)](#)

## ShipmentPeriodType

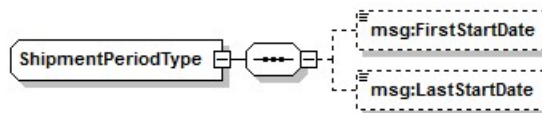

Details on the period of time during which waste is intended to be shipped.

Name/Type	min..max	Definition
FirstStartDate <a href="#">date</a>	0..1	The start date of the first intended shipment of waste under this notification.
LastStartDate <a href="#">date</a>	0..1	The start date of the last intended shipment of waste under this notification.

ShipmentPeriodType is used in: [SubmissionType \(p.121\)](#)



## StatementDocumentType

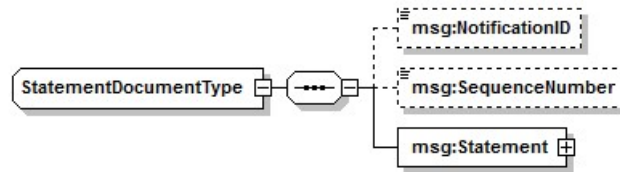

Details on a statement for exchanging information or issuing requests.

Name/Type	min..max	Definition
NotificationID <a href="#">NotificationIdentifierType (p.137)</a>	0..1	The number of the notification to which the statement is related.
SequenceNumber <a href="#">PositiveInteger8 (p.138)</a>	0..1	The sequential number of a shipment of waste to which this statement is related. Note 1: The sequential number enumerates all the shipments of waste under one notification, with "1" assigned to the first shipment, "2" to the second, and so on. Note 2: For statements related to an individual shipment of waste, both elements, NotificationID and SequenceNumber, are provided. For statements relating to a notification, but not to an individual shipment, such as for the request of further notification information, the NotificationID is provided and the SequenceNumber is omitted.
Statement <a href="#">StatementType (p.120)</a>	1..1	Details on a statement, consisting of the actual statement (free text message) and classifications of statement category, type and priority.

StatementDocumentType is used in: [MessageType \(p.91\)](#)

## StatementType

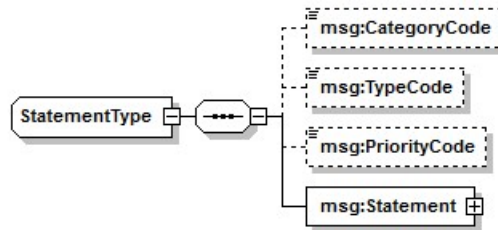

Details on a statement, including the actual statement (free text message), as well as information on the statement type and priority.

Name/Type	min..max	Definition
CategoryCode <a href="#">MessageCategoryCodeType (p.136)</a>	0..1	The code specifying whether the statement is of category "inform" (an answer or a reaction may not be needed) or of type "request" (an answer or a reaction is expected).
TypeCode <a href="#">StatementTypeCodeType (p.140)</a>	0..1	The code specifying a type of statement, such as "request for further notification information". Note: For statements not belonging to one of the pre-defined types, the TypeCode element is omitted.
PriorityCode <a href="#">PriorityCodeType (p.139)</a>	0..1	The code specifying the statement priority. Examples: "1" for "Immediate", "2" for "Urgent", "3" for "Normal". Note: Statements with a missing PriorityCode element are considered to be of "normal" priority, and should be treated equally to statements with a PriorityCode representing "Normal".
Statement <a href="#">DescriptionType (p.108)</a>	1..1	The actual statement, i.e., a free text message.

StatementType is used in: [StatementDocumentType \(p.119\)](#)

## SubmissionType



Details on a shipment of waste submitted by the notifier to competent authorities.

Name/Type	min..max	Definition
Notifier <a href="#">PartyType (p.114)</a>	0..1	ID, name, address and contact of the notifier. Note: Corresponds to block 1 of Annex IA WSR.

Consignee <a href="#">PartyType (p.114)</a>	0..1	ID, name, address and contact of the consignee. Note: Corresponds to block 2 of Annex IA WSR.
PreConsentIndicator <a href="#">boolean</a>	0..1	An indication of whether or not the notification is for a pre-consented recovery or disposal facility. Note: Corresponds to block 3C of Annex IA WSR.
ShipmentQuantity <a href="#">PositiveInteger8 (p.138)</a>	0..1	The total intended number of shipments under this notification. Note: Corresponds to block 4 of Annex IA WSR.
TotalWasteMeasurement <a href="#">NotificationMassVolumeMeasureType (p.112)</a>	0..1	The total intended quantity of waste intended to be shipped under this notification. Note: Corresponds to block 5 of Annex IA WSR.
ShipmentPeriod <a href="#">ShipmentPeriodType (p.118)</a>	0..1	The intended period of time for shipments under this notification. Note: Corresponds to block 6 of Annex IA WSR.
Packaging <a href="#">PackagingType (p.113)</a>	0..1	The packaging types intended under this notification. Note: Corresponds to block 7 of Annex IA WSR.
Carrier <a href="#">CarrierType (p.99)</a>	0..*	ID, name, address and contact of parties intended to carry the waste. Note 1: Corresponds to block 8 of Annex IA WSR. Note 2: If there are two or more Carrier element instances within a message, this corresponds to an “attached list”, whereby the order of Carrier element instances is open (e.g. alphabetical order).
WasteProducer <a href="#">WasteProducerType (p.133)</a>	0..*	ID, name, address and contact of producers of the waste intended to be carried. Note 1: Corresponds to block 9 of Annex IA WSR. Note 2: If there are two or more WasteProducer element instances within a message, this corresponds to an “attached list”, whereby the order of WasteProducer element instances is open (e.g. alphabetical order; if appropriate, a new producer could be listed first and the original producers thereafter).
InitialInterimRecoveryDisposalFacility <a href="#">RecoveryDisposalFacilityType (p.117)</a>	0..1	ID, name, address, contact and site of the first interim recovery or disposal facility. Note 1: Corresponds to Annex II Part 1 point 5 WSR. Note 2: This element is omitted if there is no interim recovery or disposal. Note 3: If there is interim recovery or disposal, then this element corresponds to blocks 10 and 11 of Annex IA WSR.
SubsequentInterimRecoveryDisposalFacility <a href="#">RecoveryDisposalFacilityType (p.117)</a>	0..*	ID, name, address, contact and site of subsequent interim recovery or disposal facilities. Note 1: Corresponds to Annex II Part 1 point 5 WSR. Note 2: This element is omitted if there is no interim recovery or disposal or no subsequent interim recovery or disposal.

<p>NonInterimRecoveryDisposalFacility  <a href="#">RecoveryDisposalFacilityType (p.117)</a></p>	0..*	<p>ID, name, address, contact and site of non-interim recovery or disposal facilities.</p> <p>Note 1: If there is no interim recovery or disposal, then only one non-interim recovery or disposal facility is expected. If there is interim recovery or disposal, there can be multiple non-interim recovery or disposal facilities.</p> <p>Note 2: If there is no interim recovery or disposal, this element corresponds to blocks 10 and 11 of Annex IA WSR.</p>
<p>WasteDesignationDescription  <a href="#">DescriptionType (p.108)</a></p>	0..1	<p>Designation of the waste intended to be shipped.</p> <p>Note 1: Corresponds to block 12 of Annex IA WSR</p> <p>Note 2: In case of additional information that would facilitate the identification of the waste would be needed corresponding to block 14 (vi) this element can be used to respect Annex IC para. 25(e).</p>
<p>PhysicalCharacteristicTypeCode  <a href="#">PhysicalCharacteristicCodeType (p.138)</a></p>	0..*	<p>Code specifying the physical characteristic of the waste intended to be shipped.</p> <p>Note: Corresponds to block 13 of Annex IA WSR.</p> <p>Example: "4" for "sludgy".</p>
<p>PhysicalCharacteristicDescription  <a href="#">DescriptionType (p.108)</a></p>	0..1	<p>Description of the physical characteristics of the waste intended to be shipped.</p> <p>Note 1: Corresponds to block 13 of Annex IA WSR.</p> <p>Note 2: A description is expected if none of the physical characteristics 1 to 6 of Annex IA and Annex IB applies, and can also be provided in addition to physical characteristics 1 to 6</p>
<p>WasteClassification  <a href="#">WasteClassificationType (p.130)</a></p>	0..1	<p>Identification of the waste intended to be shipped.</p> <p>Note 1: Corresponds to block 14 of Annex IA WSR.</p> <p>Note 2: In case additional information that would facilitate the identification of the waste needs to be provided corresponding to block 14 (vi) and Annex IC para. 25(e), such information can be provided under WasteDesignationDescription.</p>
<p>ExportState  <a href="#">ExportStateType (p.109)</a></p>	0..1	<p>Country of dispatch with competent authority and point of exit.</p> <p>Note: Corresponds to block 15 left column of Annex IA WSR.</p>
<p>ImportState  <a href="#">ImportStateType (p.109)</a></p>	0..1	<p>Country of destination with competent authority and point of entry.</p> <p>Note: Corresponds to block 15 right column of Annex IA WSR.</p>
<p>TransitState  <a href="#">TransitStateType (p.125)</a></p>	0..*	<p>Country of transit with competent authority and points of entry and exit.</p> <p>Note 1: Corresponds to block 15 middle columns of Annex IA WSR.</p> <p>Note 2: Countries of transit are expected to be provided in the order in which they are crossed from the point of dispatch to the point of destination.</p>

CustomsOfficeEntryName <a href="#">NameType (p.136)</a>	0..1	The name of the customs office of entry into the Community for shipments of waste under this notification. Note: Corresponds to block 16 of Annex IA WSR.
CustomsOfficeExitName <a href="#">NameType (p.136)</a>	0..1	The name of the customs office of exit from the Community for shipments of waste under this notification. Note: Corresponds to block 16 of Annex IA WSR.
CustomsOfficeExportName <a href="#">NameType (p.136)</a>	0..1	The name of the customs office of export from the Community for shipments of waste under this notification. Note: Corresponds to block 16 of Annex IA WSR.
AnnexQuantity <a href="#">NonNegativeInteger8 (p.136)</a>	0..1	The number of annexes to this notification. Note: IT systems may automatically pre-fill this element with the number of actual electronic annexes, but should also support manual entry of the number of annexes.

SubmissionType is used in: [NotificationDocumentType \(p.111\)](#)

## TransitCustomsDeclarationType

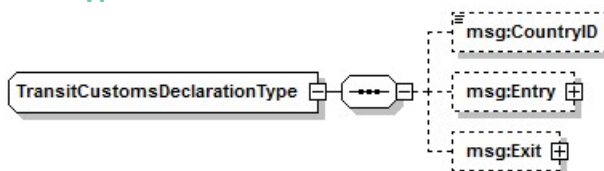

Details on a customs declaration in a country of transit.

Name/Type	min..max	Definition
CountryID <a href="#">CountryCodeType (p.134)</a>	0..1	The ISO 3166-1 numeric 3 code specifying the country of the competent authority providing the acknowledgement.
Entry <a href="#">CustomsDeclarationType (p.105)</a>	0..1	Customs declaration provided by customs office of entry in a country of transit.
Exit <a href="#">CustomsDeclarationType (p.105)</a>	0..1	Customs declaration provided by customs office of exit in a country of transit.

TransitCustomsDeclarationType is used in: [WasteMovementDocumentType \(p.131\)](#)

## TransitStateType

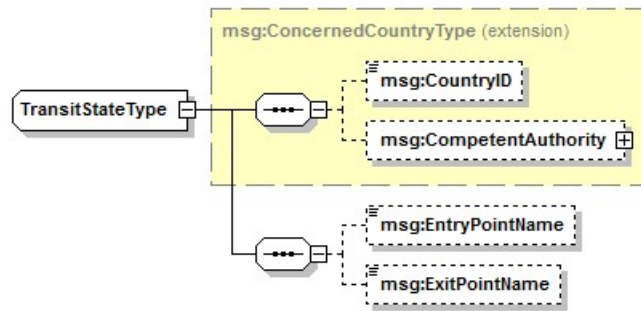

Details on a transit state, such as competent authority and points of entry and exit.

Name/Type	min..max	Definition
EntryPointName <a href="#">NameType (p.136)</a>	0..1	The name of the point of entry in the country of transit.
ExitPointName <a href="#">NameType (p.136)</a>	0..1	The name of the point of exit in the country of transit.

TransitStateType is used in: [SubmissionType \(p.121\)](#)

## TransportAnnouncementType



Details on the announcement of an individual shipment of waste.

Name/Type	min..max	Definition
Notifier <a href="#">PartyType (p.114)</a>	0..1	The notifier of this shipment of waste. Note 1: Must be identical to the notifier named in the notification under which this shipment has been consented. Note 2: Corresponds to block 3 of Annex IB WSR.
Consignee <a href="#">PartyType (p.114)</a>	0..1	The consignee of this shipment of waste. Note 1: Must be identical to the consignee named in the notification under which this shipment has been consented. Note 2: Corresponds to block 4 of Annex IB WSR.
ActualQuantity <a href="#">MassVolumeMeasureType (p.110)</a>	0..1	The actual quantity of waste to be shipped. Note: Corresponds to block 5 of Annex IB WSR.
StartDate <a href="#">date</a>	0..1	The start date of this shipment of waste. Note: Corresponds to block 6 of Annex IB WSR.



Packaging <a href="#">MovementPackagingType (p.110)</a>	0..1	Types of packaging and number of packages for this shipment of waste. Note: Corresponds to block 7 of Annex IB WSR.
Carrier <a href="#">CarrierType (p.99)</a>	0..*	Carriers conducting this shipment of waste. Note 1: Corresponds to block 8 of Annex IB WSR, without the part marked as "to be completed by the carrier's representative". Note 2: Each of the carriers must be a carrier named in the notification under which this shipment of waste has been consented. Note 3: If there are more than three Carrier element instances within a message, this corresponds to an "attached list", whereby the order of Carrier element instances reflects the order of the attached list.
WasteProducer <a href="#">WasteProducerType (p.133)</a>	0..*	Producers of the waste to be shipped. Note 1: Corresponds to block 9 of Annex IB WSR. Note 2: Each of the producers must be a producer named in the notification under which this shipment of waste has been consented. Note 3: If there are two or more WasteProducer element instances within a message, this corresponds to an "attached list", whereby the order of WasteProducer element instances is open (e.g. alphabetical order; if appropriate, a new producer could be listed first and the original producers thereafter).
InitialInterimRecoveryDisposalFacility <a href="#">RecoveryDisposalFacilityType (p.117)</a>	0..1	ID, name, address, contact and site of the first interim recovery or disposal facility. Note 1: Corresponds to Annex II Part 1 point 5 of WSR. Note 2: This element is omitted if there is no interim recovery or disposal. Note 3: If there is interim recovery or disposal, then this element corresponds to blocks 10 and 11 of Annex IB WSR. Note 4: InitialInterimRecoveryDisposal, SubsequentInterimRecoveryDisposal and NonInterimRecoveryDisposal must be identical to the elements of the same name in the notification under which this shipment has been consented regarding provision, omission and contents.
SubsequentInterimRecoveryDisposalFacility <a href="#">RecoveryDisposalFacilityType (p.117)</a>	0..*	ID, name, address, contact and site of subsequent interim recovery or disposal facilities. Note 1: Corresponds to Annex II Part 1 point 5 of WSR. Note 2: This element is omitted if there is no interim recovery or disposal or no subsequent interim recovery or disposal. Note 3: InitialInterimRecoveryDisposal, SubsequentInterimRecoveryDisposal and NonInterimRecoveryDisposal must be identical to the elements of the same name in the notification under which this shipment has been consented regarding provision, omission and contents.

<p>NonInterimRecoveryDisposalFacility  <a href="#">RecoveryDisposalFacilityType (p.117)</a></p>	0..*	<p>ID, name, address, contact and site of non-interim recovery or disposal facilities.</p> <p>Note 1: If there is no interim recovery or disposal, then only one non-interim recovery or disposal facility is expected. If there is interim recovery or disposal, there can be multiple non-interim recovery or disposal facilities.</p> <p>Note 2: If there is no interim recovery or disposal, this element corresponds to blocks 10 and 11 of Annex IB WSR.</p> <p>Note 3: InitialInterimRecoveryDisposal, SubsequentInterimRecoveryDisposal and NonInterimRecoveryDisposal must be identical to the elements of the same name in the notification under which this shipment has been consented regarding provision, omission and contents.</p>
<p>WasteDesignationDescription  <a href="#">DescriptionType (p.108)</a></p>	0..1	<p>Designation of the waste to be shipped.</p> <p>Note 1: Corresponds to block 12 of Annex IB WSR.</p> <p>Note 2: In case of additional information that would facilitate the identification of the waste would be needed corresponding to block 14 (vi) this element can be used to respect Annex IC para. 25(e).</p>
<p>PhysicalCharacteristicTypeCode  <a href="#">PhysicalCharacteristicCodeType (p.138)</a></p>	0..*	<p>Code specifying the physical characteristic of the waste to be shipped.</p> <p>Note: Corresponds to block 13 of Annex IB WSR.</p> <p>Example: "4" for "sludgy".</p>
<p>PhysicalCharacteristicDescription  <a href="#">DescriptionType (p.108)</a></p>	0..1	<p>Description of the physical characteristics of the waste to be shipped in case the physical characteristic 7 (other) is used.</p> <p>Note 1: Corresponds to block 13 of Annex IB WSR.</p> <p>Note 2: A description is expected if none of the physical characteristics 1 to 6 of Annex IA and Annex IB applies, and can also be provided in addition to physical characteristics 1 to 6.</p>
<p>WasteClassification  <a href="#">WasteClassificationType (p.130)</a></p>	0..*	<p>Identification of the waste to be shipped.</p> <p>Note 1: Corresponds to block 14 of Annex IB WSR.</p> <p>Note 2: In case additional information that would facilitate the identification of the waste needs to be provided corresponding to block 14 (vi) and Annex IC para. 25(e), such information can be provided under WasteDesignationDescription.</p>
<p>AdditionalInformation  <a href="#">DescriptionType (p.108)</a></p>	0..*	<p>Additional information on the shipment of waste.</p> <p>Note: Corresponds to block 16 of Annex IB WSR.</p>

TransportAnnouncementType is used in: [WasteMovementDocumentType \(p.131\)](#)

## TransportType

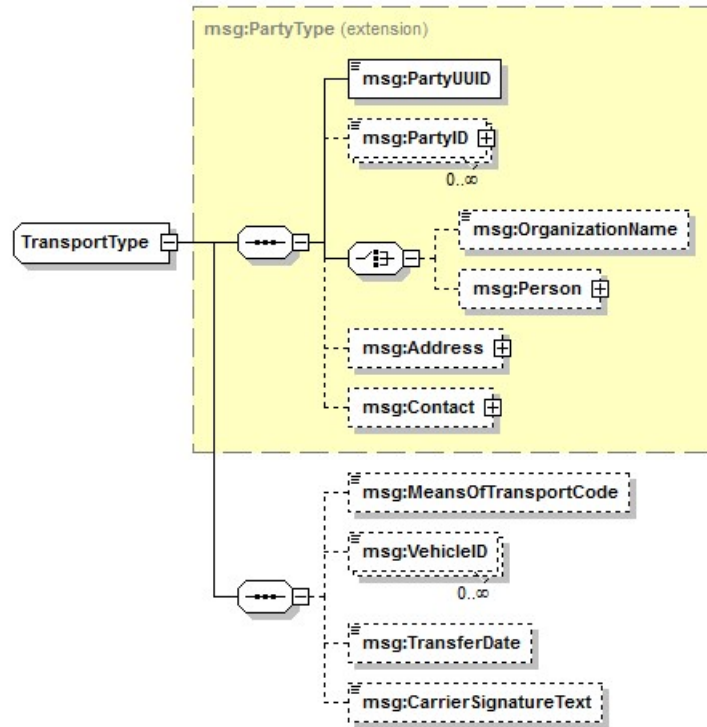

Details on a transport, such as means of transport and transfer date.

Name/Type	min..max	Definition
MeansOfTransportCode <a href="#">MeansOfTransportCodeType (p.135)</a>	0..1	The code specifying the means of transport. Example: "R" for road, "T" for train. Note: The WSR may define different codes in its various translations. In the electronic data interchange the codes from the English version of the regulation MUST be used, independent of the countries involved and independent of the language used in the document.
VehicleID <a href="#">Token64 (p.140)</a>	0..*	An identification of the vehicle with which the transport is carried out, such as a license plate number. Note: The WSR does not require vehicle IDs to be specified.
TransferDate <a href="#">date</a>	0..1	The date of waste transfer.
CarrierSignatureText <a href="#">String256 (p.140)</a>	0..1	Text to be printed/displayed at the carrier's signature element in a layout following Annex IB or Annex VII of the WSR.

TransportType is used in: [Annex7DocumentType \(p.96\)](#), [WasteMovementDocumentType \(p.131\)](#)

## VendorType

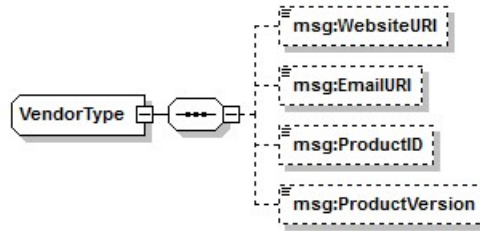

Details on a software product and its vendor.

Name/Type	min..max	Definition
WebsiteURI <a href="#">URIType (p.141)</a>	0..1	URI of a website with information on the software product or its vendor.
EmailURI <a href="#">URIType (p.141)</a>	0..1	A contact email address for the software product or its vendor.
ProductID <a href="#">String256 (p.140)</a>	0..1	An identifier by which the software with which the message was generated can be recognized.
ProductVersion <a href="#">String256 (p.140)</a>	0..1	The version of the software instance with which the message was generated.

VendorType is used in: [MessageType \(p.91\)](#)

## WasteClassificationType

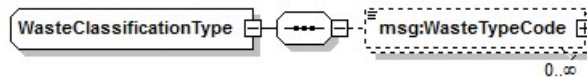

Waste classifications.

Name/Type	min..max	Definition
WasteTypeCode <a href="#">WasteCodeType (p.142)</a>	0..*	<p>The code specifying the type of waste, together with a listID or listName attribute specifying the waste list from which the code is taken.</p> <p>Example: "A 1050" for "Galvanic sludges" in combination with listID set to "BASEL" (Basel Annex VIII).</p> <p>Note: According to the second subparagraph, point 6 of Article 4 of the WSR, only one waste code is expected, with two exceptions (see also the chapeau of para. 25 in Annex IC WSR).</p>

WasteClassificationType is used in: [Annex7TransportAnnouncementType \(p.97\)](#), [SubmissionType \(p.121\)](#), [TransportAnnouncementType \(p.126\)](#)

## WasteMovementDocumentType



Details on a movement document as defined in Annex IB WSR.

Name/Type	min..max	Definition
NotificationID <a href="#">NotificationIdentifierType (p.137)</a>	1..1	The number of the notification under which the shipment of waste has been consented. Note: Corresponds to block 1 of Annex IB WSR.
SequenceNumber <a href="#">PositiveInteger8 (p.138)</a>	1..1	A sequential number assigned to the shipment of waste, enumerating all the shipments of waste under one notification, with "1" assigned to the first shipment, "2" to the second, and so on. Note 1: A sequence number typically must not be reused. This also applies when shipments of waste are cancelled. The number of the cancelled shipment must not be reused for a new shipment. Note 2: Corresponds to block 2 of Annex IB WSR.
ShipmentQuantity <a href="#">PositiveInteger8 (p.138)</a>	0..1	The total number of shipments consented under the notification. Note: Corresponds to block 2 of Annex IB WSR.
TransportAnnouncement <a href="#">TransportAnnouncementType (p.126)</a>	0..1	The notifier's announcement of a shipment of waste. Note: Corresponds to blocks 3 to 14 of Annex IB WSR, with the exception of the part marked as "to be completed by the carrier's representative" under block 8.
DeclarationExporter <a href="#">DeclarationType (p.108)</a>	0..1	Notifier's declaration. Note: Corresponds to block 15 of Annex IB WSR.

DeclarationProducer <a href="#">DeclarationType (p.108)</a>	0..1	Producer's declaration. Note: Corresponds to block 15 of Annex IB WSR.
Transport <a href="#">TransportType (p.129)</a>	0..*	Waste shipment related information provided by carriers. Note: Corresponds to the part marked as "to be completed by carrier's representative" under block 8 of Annex IB WSR.
CertificateOfWasteReceipt <a href="#">CertificateOfWasteReceiptType (p.101)</a>	0..*	Waste receipt related information typically provided by a recovery or disposal facility. Note: Corresponds to block 17 of Annex IB WSR.
CertificateOfCompletion <a href="#">CertificateOfCompletionType (p.100)</a>	0..*	Information on the completion of a waste recovery or disposal operation provided by a recovery or disposal facility. Note: Corresponds to block 18 of Annex IB WSR.
ExitCustomsDeclaration <a href="#">CustomsDeclarationType (p.105)</a>	0..1	Customs declaration provided by the customs office of exit in the country of dispatch. Note: Corresponds to block 19 of Annex IB WSR.
EntryCustomsDeclaration <a href="#">CustomsDeclarationType (p.105)</a>	0..1	Customs declaration provided by the customs office of entry in the country of destination. Note: Corresponds to block 20 of Annex IB WSR.
TransitCustomsDeclaration <a href="#">TransitCustomsDeclarationType (p.124)</a>	0..*	Customs declaration provided by customs offices of entry and exit in countries of transit. Note 1: Corresponds to block 21 of Annex IB WSR. Note 2: Expected to be provided in the order in which transit countries are crossed from the point of dispatch to the point of destination.

WasteMovementDocumentType is used in: [MessageType \(p.91\)](#)

## WasteProducerType

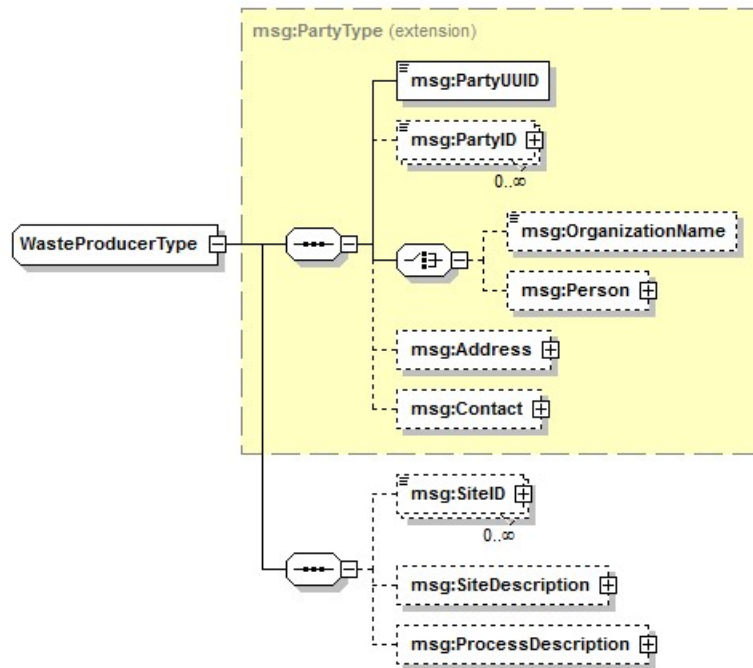

Details on a waste producer, such as name, address and waste production site.

Name/Type	min..max	Definition
SiteID <a href="#">SiteIdentifierType (p.139)</a>	0..*	Site identifiers (registration no) such as the GLN (Global Location Number). Note: For each classification scheme only one identifier is allowed.
SiteDescription <a href="#">DescriptionType (p.108)</a>	0..1	The description of the waste production site, such as name and address.
ProcessDescription <a href="#">DescriptionType (p.108)</a>	0..1	The description of the waste production process.

WasteProducerType is used in: [SubmissionType \(p.121\)](#), [TransportAnnouncementType \(p.126\)](#)

## Simple content types

### BinaryAttachmentClassificationCodeType

Name/Type	min..max	Definition
BinaryAttachmentClassificationCodeType <a href="#">Token (p.140)</a>	1..1	A code specifying a type of binary attachment. Examples: "DealerBrokerContract", "LiabilityInsurance", "FinancialGuarantee".

BinaryAttachmentClassificationCodeType is used in: [BinaryObject \(p.134\)](#)

## BinaryObject

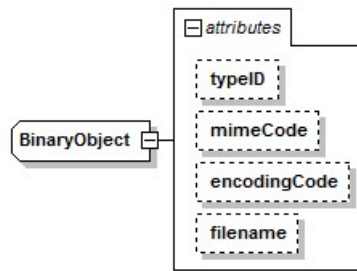

Name/Type	min..max	Definition
BinaryObject <a href="#">base64Binary</a>	1..1	A binary object in base64 representation.
typeID <a href="#">BinaryAttachmentClassificationCodeType</a> (p.133)	0..1	A code specifying the type of binary object. Examples: "DealerBrokerContract", "LiabilityInsurance", "FinancialGuarantee".
mimeType <a href="#">Token64</a> (p.140)	0..1	A Multipurpose Internet Mail Extension (MIME) Content-Type code providing information about the content and format of the binary object, such as "image/png" for images in "Portable Network Graphics" (PNG) format.
encodingCode <a href="#">Token64</a> (p.140)	0..1	A Multipurpose Internet Mail Extension (MIME) Content Transfer Encoding code providing information about the type of textual representation of the binary object. This has to be set to "base64".
filename <a href="#">NameType</a> (p.136)	0..1	A file name associated with the binary object. Example: "contract.pdf"

BinaryObject is used in: [BinaryAttachmentType](#) (p.99)

## CountryCodeType

Name/Type	min..max	Definition
CountryCodeType <a href="#">String</a> (p.140)	1..1	An ISO 3316-1 numeric country code. Example: "428" for Latvia.

CountryCodeType is used in: [AcknowledgementType](#) (p.94), [AddressType](#) (p.95), [Annex7ConcernedCountryType](#) (p.96), [ConcernedCountryType](#) (p.104), [DecisionType](#) (p.106), [TransitCustomsDeclarationType](#) (p.124), [PartyIdentificationSchemeOrCountryIdentifierType](#) (p.137), [WasteClassificationSchemeOrCountryIdentifierType](#) (p.141)

## CountryRoleIDType

Name/Type	min..max	Definition
CountryRoleIDType <a href="#">Token</a> (p.140)	1..1	A code specifying the role of a country. Note: "E" for country of dispatch/export, "I" for country of destination/import, or "T" for country of transit.

CountryRoleIDType is used in: [Annex7ConcernedCountryType](#) (p.96)



### Decimal25Fraction5Type

Name/Type	min..max	Definition
Decimal25Fraction5Type <a href="#">decimal</a>	1..1	A decimal number with a maximum length of 25 decimal digits, and at most 5 fractional digits.

Decimal25Fraction5Type is used in: [MeasureType \(p.136\)](#)

### GenderCodeType

Name/Type	min..max	Definition
GenderCodeType <a href="#">Token (p.140)</a>	1..1	A code specifying gender, following ISO 5218. Note: "1" for male, "2" for female.

GenderCodeType is used in: [PersonType \(p.116\)](#)

### LanguageDescriptionType

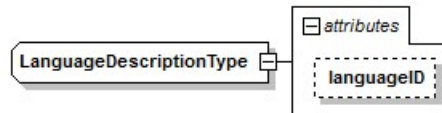

Name/Type	min..max	Definition
LanguageDescriptionType <a href="#">String1024 (p.140)</a>	1..1	A textual description provided in a specific language.
languageID <a href="#">LanguageIdentifierType (p.135)</a>	0..1	The ISO 639-1 code of the language the textual description is provided in.

LanguageDescriptionType is used in: [DescriptionType \(p.108\)](#)

### LanguageIdentifierType

Name/Type	min..max	Definition
LanguageIdentifierType <a href="#">String (p.140)</a>	1..1	An ISO 639-1 code specifying a language. Examples: "en" for English, "de" for German, "lt" for Lithuanian.

LanguageIdentifierType is used in: [LanguageDescriptionType \(p.135\)](#)

### MeansOfTransportCodeType

Name/Type	min..max	Definition
MeansOfTransportCodeType <a href="#">Token (p.140)</a>	1..1	A code specifying a means of transport. Examples: "R" for road, "T" for train, "S" for sea.

MeansOfTransportCodeType is used in: [CarrierType \(p.99\)](#), [TransportType \(p.129\)](#)

## MeasureType

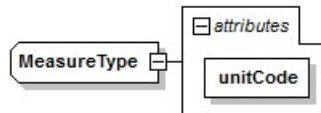

Name/Type	min..max	Definition
MeasureType <a href="#">Decimal25Fraction5Type</a> (p.135)	1..1	The numeric value of a measure, in combination with a unit of measurement specified in the unitCode attribute.
unitCode <a href="#">Token64</a> (p.140)	1..1	The case sensitive (c/s) Unified Code for Units of Measure (UCUM) for this measurement. Example: "t" for tonnes, "kg" for kilograms, "m3" for cubic meters or "l" for liters.

MeasureType is used in: [MassVolumeMeasureType](#) (p.110), [NotificationMassVolumeMeasureType](#) (p.112)

## MessageCategoryCodeType

Name/Type	min..max	Definition
MessageCategoryCodeType <a href="#">Token</a> (p.140)	1..1	A code specifying a message category. Note: "inform" (messages meant for information only) or "request" (messages meant to be reacted upon).

MessageCategoryCodeType is used in: [StatementType](#) (p.120)

## NameType

Name/Type	min..max	Definition
NameType <a href="#">NormalizedString</a> (p.136)	1..1	A name, such as the name of an organization.

NameType is used in: [CommunicationType](#) (p.103), [DeclarationType](#) (p.108), [ExportStateType](#) (p.109), [ImportStateType](#) (p.109), [PartyType](#) (p.114), [SubmissionType](#) (p.121), [TransitStateType](#) (p.125), [BinaryObject](#) (p.134)

## NonNegativeInteger8

Name/Type	min..max	Definition
NonNegativeInteger8 <a href="#">nonNegativeInteger</a>	1..1	A non-negative integer with at most 8 decimal digits.

NonNegativeInteger8 is used in: [SubmissionType](#) (p.121)

## NormalizedString

Name/Type	min..max	Definition
NormalizedString <a href="#">NormalizedString</a> (p.136)	1..1	A normalized string, i.e., a string not containing carriage return (#xD), line feed (#xA) and tab (#x9), with a minimum length of 1 character.

NormalizedString is used in: [NameType](#) (p.136), [PersonNameType](#) (p.138)

## NotificationIdentifierType

Name/Type	min..max	Definition
NotificationIdentifierType <a href="#">Token (p.140)</a>	1..1	The number/identifier assigned to a notification of shipments of waste. Example: "LT001209" Note: By convention, a notification identifier is expected to start with the ISO 3166-1 alpha-2 identifier of the country of dispatch, such as "LT" for "Lithuania".

NotificationIdentifierType is used in: [NotificationDocumentType \(p.111\)](#), [StatementDocumentType \(p.119\)](#), [WasteMovementDocumentType \(p.131\)](#)

## PackageCodeType

Name/Type	min..max	Definition
PackageCodeType <a href="#">Token (p.140)</a>	1..1	A code specifying a type of package. Examples: "4" for box, "6" for composite packaging.

PackageCodeType is used in: [PackagingType \(p.113\)](#)

## PartyIdentificationSchemeIdentifierType

Name/Type	min..max	Definition
PartyIdentificationSchemeIdentifierType <a href="#">Token (p.140)</a>	1..1	A code specifying a party identification scheme, such as a register from which a party ID is taken. Examples: "VAT" for Value Added Tax number, "NTR" for National Trade Register number.

PartyIdentificationSchemeIdentifierType is used in: [PartyIdentificationSchemeOrCountryIdentifierType \(p.137\)](#)

## PartyIdentificationSchemeOrCountryIdentifierType

Name/Type	min..max	Definition
PartyIdentificationSchemeOrCountryIdentifierType <a href="#">PartyIdentificationSchemeIdentifierType (p.137)</a> <a href="#">CountryCodeType (p.134)</a>	1..1	A code specifying a party identification scheme. Note: Numeric ISO 3166-1 country codes are used to represent national identifiers. Examples: "VAT" for Value Added Tax number, "NTR" for National Trade Register number, "GLN" for Global Location Number, or "428" for a Latvian national identifier.

PartyIdentificationSchemeOrCountryIdentifierType is used in: [PartyIdentifierType \(p.138\)](#)

## PartyIdentifierType

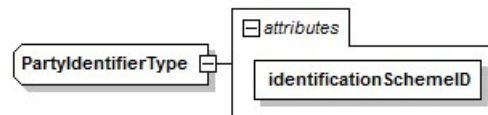

Name/Type	min..max	Definition
PartyIdentifierType <a href="#">Token64 (p.140)</a>	1..1	Identification of a party, such as VAT number (Value Added Tax) or GLN (Global Location Number).
identificationSchemeID <a href="#">PartyIdentificationSchemeOrCountryIdentifierType (p.137)</a>	1..1	The code specifying the identification scheme. Examples: "VAT", "GLN".

PartyIdentifierType is used in: [PartyType \(p.114\)](#)

## PersonNameType

Name/Type	min..max	Definition
PersonNameType <a href="#">NormalizedString (p.136)</a>	1..1	A name of a person, such as given name or family name.

PersonNameType is used in: [PersonType \(p.116\)](#)

## PhoneType

Name/Type	min..max	Definition
PhoneType <a href="#">String (p.140)</a>	1..1	A telephone number.

PhoneType is used in: [ContactType \(p.105\)](#)

## PhysicalCharacteristicCodeType

Name/Type	min..max	Definition
PhysicalCharacteristicCodeType <a href="#">Token (p.140)</a>	1..1	A code specifying a physical characteristic. Examples: "2" for solid, "5" for liquid.

PhysicalCharacteristicCodeType is used in: [SubmissionType \(p.121\)](#), [TransportAnnouncementType \(p.126\)](#)

## PositiveInteger8

Name/Type	min..max	Definition
PositiveInteger8 <a href="#">positiveInteger</a>	1..1	A positive integer with at most 8 decimal digits.

PositiveInteger8 is used in: [MovementPackagingType \(p.110\)](#), [StatementDocumentType \(p.119\)](#), [SubmissionType \(p.121\)](#), [WasteMovementDocumentType \(p.131\)](#)

## PriorityCodeType

Name/Type	min..max	Definition
PriorityCodeType <a href="#">Token (p.140)</a>	1..1	A code specifying a message priority. Note: "1" for Immediate (to be dealt with immediately), "2" for Urgent (to be dealt with before any non-urgent task) or "3" for Normal (to be dealt with as routine work).

PriorityCodeType is used in: [StatementType \(p.120\)](#)

## RecoveryDisposalCodeType

Name/Type	min..max	Definition
RecoveryDisposalCodeType <a href="#">Token (p.140)</a>	1..1	A code specifying a type of recovery or disposal operation. Example: "R6" for regeneration of acids or bases.

RecoveryDisposalCodeType is used in: [CertificateOfWasteReceiptType \(p.101\)](#), [RecoveryDisposalFacilityType \(p.117\)](#)

## RejectionIndicatorType

Name/Type	min..max	Definition
RejectionIndicatorType <a href="#">Token (p.140)</a>	1..1	A code specifying whether or not something is rejected or partially rejected. Note: "A" for accepted, "P" for partially accepted/rejected, "R" for fully rejected.

## SiteIdentificationSchemeIdentifierType

Name/Type	min..max	Definition
SiteIdentificationSchemeIdentifierType <a href="#">Token (p.140)</a>	1..1	A code specifying a site identification scheme, such as a register from which a site ID is taken. Example: "GLN" for Global Location Number.

SiteIdentificationSchemeIdentifierType is used in: [SiteIdentifierType \(p.139\)](#)

## SiteIdentifierType

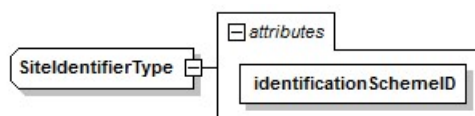

Name/Type	min..max	Definition
SiteIdentifierType <a href="#">Token64 (p.140)</a>	1..1	Identification of a site, such as GLN (Global Location Number).
identificationSchemeID <a href="#">SiteIdentificationSchemeIdentifierType (p.139)</a>	1..1	The code specifying the identification scheme. Example: "GLN".

SiteIdentifierType is used in: [RecoveryDisposalFacilityType \(p.117\)](#), [WasteProducerType \(p.133\)](#)

## StatementTypeCodeType

Name/Type	min..max	Definition
StatementTypeCodeType <a href="#">Token (p.140)</a>	1..1	A code specifying the type of Statement message, such as "RequestForNotificationInformation" (a competent authority's request for notification information and documentation pursuant to Articles 4, 7 and 8 WSR).

StatementTypeCodeType is used in: [StatementType \(p.120\)](#)

## String

Name/Type	min..max	Definition
String <a href="#">String (p.140)</a>	1..1	A string with a minimum length of 1 character.

String is used in: [CountryCodeType \(p.134\)](#), [LanguageIdentifierType \(p.135\)](#), [PhoneType \(p.138\)](#), [String1024 \(p.140\)](#), [String256 \(p.140\)](#)

## String1024

Name/Type	min..max	Definition
String1024 <a href="#">String (p.140)</a>	1..1	A string with a maximum length of 1024 characters and a minimum length of 1 character.

String1024 is used in: [LanguageDescriptionType \(p.135\)](#), [WasteCodeType \(p.142\)](#)

## String256

Name/Type	min..max	Definition
String256 <a href="#">String (p.140)</a>	1..1	A string with a maximum length of 256 characters and a minimum length of 1 character.

String256 is used in: [AcknowledgementType \(p.94\)](#), [CustomsDeclarationType \(p.105\)](#), [DecisionType \(p.106\)](#), [DeclarationType \(p.108\)](#), [TransportType \(p.129\)](#), [VendorType \(p.130\)](#)

## Token

Name/Type	min..max	Definition
Token <a href="#">Token (p.140)</a>	1..1	A token, i.e., a string not containing carriage return (#xD), line feed (#xA) nor tab (#x9) characters, not containing leading or trailing spaces (#x20) and not containing internal sequences of two or more spaces, with a minimum length of 1 character.

Token is used in: [AddressType \(p.95\)](#), [NotificationIdentifierType \(p.137\)](#), [Token64 \(p.140\)](#), [URIType \(p.141\)](#)

## Token64

Name/Type	min..max	Definition
Token64 <a href="#">Token</a> (p.140)	1..1	A token, i.e., a string not containing carriage return (#xD), line feed (#xA) nor tab (#x9) characters, not containing leading or trailing spaces (#x20) and not containing internal sequences of two or more spaces, with a maximum length of 64 characters and a minimum length of 1 character.

Token64 is used in: [MessageType](#) (p.91), [CompetentAuthorityType](#) (p.104), [TransportType](#) (p.129), [BinaryObject](#) (p.134), [MeasureType](#) (p.136), [PartyIdentifierType](#) (p.138), [SiteIdentifierType](#) (p.139)

## Token64OrEmpty

Name/Type	min..max	Definition
Token64OrEmpty <a href="#">Token</a> (p.140)	1..1	A token, i.e., a string not containing carriage return (#xD), line feed (#xA) nor tab (#x9) characters, not containing leading or trailing spaces (#x20) and not containing internal sequences of two or more spaces, with a maximum length of 64 characters.

Token64OrEmpty is used in: [WasteCodeType](#) (p.142)

## URIType

Name/Type	min..max	Definition
URIType <a href="#">Token</a> (p.140)	1..1	A Uniform Resource Identifier (URI) following RFC 3986 with a maximum length of 200 characters and a minimum length of 1 character.

URIType is used in: [ContactType](#) (p.105), [VendorType](#) (p.130)

## UuidType

Name/Type	min..max	Definition
UuidType <a href="#">String</a> (p.140)	1..1	Universally Unique ID (UUID) following IETF RFC 4122.

UuidType is used in: [MessageType](#) (p.91), [CommunicationType](#) (p.103), [PartyType](#) (p.114)

## WasteClassificationSchemeIdentifierType

Name/Type	min..max	Definition
WasteClassificationSchemeIdentifierType <a href="#">Token</a> (p.140)	1..1	A code specifying a waste list (waste classification scheme). Example: "BASEL" for Basel Convention Annex VIII.

WasteClassificationSchemeIdentifierType is used in: [WasteClassificationSchemeOrCountryIdentifierType](#) (p.141)

## WasteClassificationSchemeOrCountryIdentifierType

Name/Type	min..max	Definition
<b>WasteClassificationSchemeOrCountryIdentifierType</b> <a href="#">WasteClassificationSchemeIdentifierType (p.141)</a> <a href="#">CountryCodeType (p.134)</a>	1..1	A code specifying a waste list (a classification of wastes). Note: A numeric ISO 3166-1 code can be used for national waste lists. Examples: "BASEL" for Basel Convention Annex VIII Codes such as A1010, "EWL" for European Waste List, "YCODE" for Basel Convention Y-Codes, "233" for the national waste classification of Estonia.

WasteClassificationSchemeOrCountryIdentifierType is used in: [WasteCodeType \(p.142\)](#)

## WasteCodeType

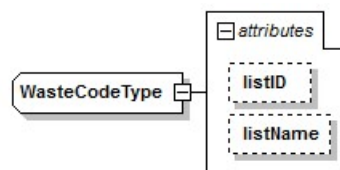

Name/Type	min..max	Definition
<b>WasteCodeType</b> <a href="#">Token64OrEmpty (p.141)</a>	1..1	A code specifying a type of waste, in combination with a listID or listName attribute specifying the list from which the waste type code is taken.
<b>listID</b> <a href="#">WasteClassificationSchemeOrCountryIdentifierType (p.141)</a>	0..1	The code specifying the waste list. Example: "EWL" for European Waste List. Note: Instead of referencing one of the enumerated waste lists such as European Waste List this can alternatively be set to a country code for a national waste classification.
<b>listName</b> <a href="#">String1024 (p.140)</a>	0..1	The name of the waste list from which the waste code is taken. Note: Waste list names are expected only for lists which cannot be specified by code.

WasteCodeType is used in: [WasteClassificationType \(p.130\)](#)