

# EUROPEAN ECONOMY

No 5 / 2007

Annual Report  
on the Euro Area 2007



European  
Commission



Economic  
and Financial Affairs

DIRECTORATE GENERAL

## **SALES AND SUBSCRIPTIONS**

Publications for sale produced by the Office for Official Publications of the European Communities are available from our sales agents throughout the world.

You can find the list of sales agents on the Publications Office website (<http://publications.europa.eu>) or you can apply for it by fax (352) 29 29-42758.

Contact the sales agent of your choice and place your order.

**European Commission**

# **EUROPEAN ECONOMY**

**Directorate-General for Economic and Financial Affairs**

**2007**

**No 5**



# **Annual Report on the Euro Area 2007**

---

**June 2007**

## Abbreviations and symbols used

### Member States

BE	Belgium
CZ	Czech Republic
DK	Denmark
DE	Germany
EE	Estonia
EL	Greece
ES	Spain
FR	France
IE	Ireland
IT	Italy
CY	Cyprus
LV	Latvia
LT	Lithuania
LU	Luxembourg
HU	Hungary
MT	Malta
NL	The Netherlands
AT	Austria
PL	Poland
PT	Portugal
SI	Slovenia
SK	Slovakia
FI	Finland
SE	Sweden
UK	United Kingdom

EUR-12	European Union Member States having adopted the single currency (BE, DE, EL, ES, FR, IE, IT, LU, NL, AT, PT, FI)
EU-25	European Union, 25 Member States
EU-15	European Union, 15 Member States before 1 May 2004 (EUR-12 plus DK, SE and UK)
EU-10	European Union, 10 Member States that joined the EU on 1 May 2004 (CZ, EE, CY, LV, LT, HU, MT, PL, SI, SK)

### Currencies

EUR	euro
ECU	European currency unit
DKK	Danish krone
GBP	Pound sterling
SEK	Swedish krona
CAD	Canadian dollar
CHF	Swiss franc
JPY	Japanese yen
SUR	Russian rouble
USD	US dollar

**Other abbreviations**

SCPs	Stability and convergence programmes
PEPs	Pre-accession economic programmes
NMS	New Member States
SGP	Stability and Growth Pact





# Contents

**I. Annual Statement on the Euro Area**

**II Annual Report on the Euro Area**



# **Annual Statement on the Euro Area**

A Commission communication

COM(2007) 231 final

[http://ec.europa.eu/economy\\_finance/publications/european\\_economy/2007/euro\\_area2007\\_en.htm](http://ec.europa.eu/economy_finance/publications/european_economy/2007/euro_area2007_en.htm)





COMMISSION OF THE EUROPEAN COMMUNITIES

Brussels, 03 May 2007  
COM(2007) 231 final

**COMMUNICATION FROM THE COMMISSION TO THE COUNCIL, THE  
EUROPEAN PARLIAMENT, THE EUROPEAN ECONOMIC AND SOCIAL  
COMMITTEE, THE COMMITTEE OF THE REGIONS  
AND THE EUROPEAN CENTRAL BANK**

**– Annual Statement on the Euro Area 2007 –**



## I. INTRODUCTION

1. ***Earlier this year, European leaders endorsed a solemn declaration in Berlin to mark the 50<sup>th</sup> Anniversary of the Treaty of Rome and reaffirmed their commitment to a project that has paved the way for peace and prosperity in Europe.*** Economic integration is central to this European success story. A gradual elimination of economic barriers over the last half-century has helped to raise living standards, ensure a fairer deal for consumers, create new opportunities for investors and foster closer economic and political ties between Member States. As the Berlin declaration says, "the common market and the euro make us strong".

2. ***Economic and Monetary Union (EMU) is the most advanced stage of European economic integration to date and it will continue to be an important driver of ever closer union in the coming years.*** For the 318 million people that use the euro on a daily basis, the single currency is a tangible symbol of the shared successes and challenges facing Europeans. Since the euro was launched in 1999, EMU has delivered a high degree of macroeconomic stability and encouraged closer trade and investment ties and deeper financial-market integration in the euro area. During this time, the euro has emerged as a major global currency and is now widely used as an anchor or reference currency in foreign-exchange arrangements and as an official reserve currency. These and other benefits from EMU should represent strong incentives for countries to sign up to the euro.

3. ***Encouraged by Slovenia's adoption of the euro on 1 January 2007, other Member States are stepping up their preparations to enter the euro area.*** Earlier this year, Cyprus and Malta submitted formal requests to the European Commission and the ECB to prepare Convergence Reports on the basis of which the Council of Ministers will decide whether these Member States can join the euro area on 1 January 2008.

4. ***There is a growing awareness that being a member of the euro area means confronting common challenges and responsibilities.*** At this year's Spring European Council, EU leaders, in their annual assessment of the renewed Lisbon Strategy, endorsed a new set of euro-area specific recommendations in the context of the Integrated Guidelines for Growth and Jobs. The recommendations emphasise the need for prudent fiscal policies, improvements in the quality of public finances and greater adaptability in the markets for goods and services. They also call for a better alignment of wage and productivity developments and an accelerated pace of financial-market integration.

5. ***The Annual Statement on the Euro Area, and its companion piece, the Annual Report on the Euro Area, present the Commission's views on how euro-area countries can meet their shared responsibilities and challenges.*** They are also designed to inform the debate on the euro-area's economic performance and the functioning of EMU. The Annual Statement on the Euro Area also serves as a contribution to the European Commission's dialogue with the European Parliament on euro-area economic policy.

## II. THE EURO-AREA'S RENEWED ECONOMIC VIGOUR

6. ***Since last year's Annual Statement on the Euro Area, the euro-area's economic recovery has gone from strength to strength.*** The euro-area grew by 2.7% last year, its fastest growth rate since 2000, and well-above its long-term average. Employment growth accelerated to around 1.5% in 2006 in the euro area, yielding an increase of close to 2 million new jobs.

Inflation remained around 2% in 2006 but it came down towards the year's end as energy prices eased.

**7. *The euro-area's positive growth performance partly reflects the current cyclical upturn but it may also show that structural reforms are beginning to take effect.*** There are signs of an increased resilience to global disturbances. The employment effect of recent growth has been particularly intense. In December 2006, the unemployment rate dropped to 7.5%, its lowest level in 15 years. Labour productivity growth in the euro area averaged 1% in 2006, compared with an annual average rate of 0.7% during the previous decade, and several factors indicate that this rebound could be more than just cyclical in nature. Overall, these developments suggest that Member States are being rewarded for their efforts to, *inter alia*, increase labour participation rates, boost R&D and innovation, develop human capital and create a more attractive and competitive business environment. They also show the benefits of a macroeconomic framework that is designed to enhance stability and promote greater certainty about medium-term economic prospects.

**8. *Domestic demand is an important driver of economic growth in the euro area.*** This is reflected in the continued buoyancy of investment spending and the revival in household spending thanks, in part, to greater consumer confidence and the euro-area's strong employment performance. Euro-area exports also made a positive contribution to growth despite less favourable economic conditions in some of its key trading partners and the appreciation of the euro.

**9. *The prospects for continued economic growth in the euro area are more favourable in 2007 than they have been for many years.*** Domestic demand is expected to maintain its relatively strong momentum, with investment benefiting from ongoing favourable financial conditions, improved corporate balance sheets, the need for replacement investment, productivity gains and a positive outlook for profits. Global economic growth is likely to moderate somewhat but euro-area exports are well placed to continue their strong performance.

**10. *As ever, there may be economic surprises around the corner.*** A disorderly correction of global imbalances, exchange-rate tensions and geo-political developments are among the factors that could lead to lower-than-expected growth in the euro area. Conversely, a stronger labour market performance and a more-benign-than-expected impact of ongoing fiscal consolidation efforts could lead to higher-than-expected growth.

### **III. PUTTING THE MACROECONOMIC HOUSE IN ORDER**

**11. *Macroeconomic policy needs to be on a sound footing for the euro-area's economic recovery to continue.*** Since December 2005, the European Central Bank has been withdrawing the stimulus provided in recent years in view of the medium-term risks to price stability. Alongside this, the process of wage determination in euro-area members must pay sufficient regard to price stability, trends in productivity over the medium-term and differences across skills and local labour-market conditions. Wages in the euro area continued to grow moderately in 2006 in spite of price developments and strong output and employment growth. Although significant cross-country differences remain, overall wage growth in the euro area appears to have been dampened since the 1990s, thus reducing the potential for second-round effects induced by the previous oil price increases. In the budgetary sphere, it is essential that Member States seize the opportunity created by the economic upturn to complete the consolidation of their budgetary positions before the end of the decade. Such fiscal consolidation would also enhance the euro-area's overall fiscal-monetary policy mix.



**12. Euro-area members have made a concerted effort to correct excessive budget deficits.** On 30 January 2007, the Council decided that the excessive deficit procedure against France should be closed as its budget deficit remained below 3% also in 2006. In Germany, the economic recovery has helped to bring the budget deficit below 3% of GDP one year ahead of schedule. In Greece, there has been a strong correction in 2006 which has led the budget deficit to remain at 2.6% of GDP. Portugal and Italy have also recorded a significant structural improvement in 2006, masked in the case of the latter by the effect of one-off measures. In the euro area as a whole, the quality of the adjustment has increased, with less reliance on one-off measures, and a decrease in public expenditure. Overall, the combination of the consolidation efforts, notably in countries with excessive deficits, and improved economic developments, leading to substantially higher-than expected revenues, has reduced the euro-area's budget deficit to 1.6% of GDP in 2006, down from 2.5% of GDP in 2005.

**13. Member States, especially those that are in the process of correcting excessive deficits, must press ahead with budgetary consolidation to meet their medium-term budgetary objectives.** Some Member States planned little or no improvement in their structural balances in their 2006 Stability Programmes, even though the Stability and Growth Pact calls for budgetary consolidation that goes beyond the benchmark of 0.5% of GDP during the good times. France, for example, in its programme, plans to improve its structural balance by just 0.3 percentage points of GDP in 2007. Germany in its stability programme plans no improvement of its structural balance in 2008 even though "good times" are forecast. Some euro-area members that have reached their medium-term objectives are at risk of a pro-cyclical fiscal stance in 2007, notably in the Netherlands where a significant deterioration is expected this year even though "good times" are forecast. This situation calls for renewed efforts: Member States that fail to make sufficient progress in spite of the favourable growth may not achieve a sufficient safety margin against breaching the 3% of GDP deficit threshold if and when the pace of economic growth slows, thus repeating the policy mistakes of the late 1990s. At the same time the reappearance of structural deficits in countries already in balance or in surplus should also be avoided.

**14. On 20 April 2007, the Eurogroup adopted orientations for fiscal policies in euro area Member States, recalling the commitment to actively consolidate public finances in good times and to use unexpected extra revenues for deficit and debt reduction.** With a view to improving the coordination of fiscal policies, euro area Finance Ministers discussed national budgetary developments in 2007 and the preliminary policy outlook for 2008 and their implications for the euro area. Firstly, they committed to build on the better-than-expected budgetary outcomes in 2006 and to pursue more ambitious budgetary targets than those set in the 2006 Stability Programmes. Secondly, they agreed to implement budgets for 2007 as planned, avoiding expenditure overruns, and using unexpected extra revenues to reduce government deficit and debt. Thirdly, it was agreed that fiscal policy plans for 2008 should be carefully designed so as to accelerate adjustment towards the medium-term budgetary objectives for Member States which have not reached it and for those which have reached it to avoid fuelling macroeconomic imbalances.

**15. The euro-area's strong growth performance presents a golden opportunity for all euro-area members to put their fiscal houses in order.** On the revenue side, there is a strong economic case for using revenue windfalls – i.e. from unexpectedly high economic growth – to reduce government borrowing. On the expenditure side, the experience of some Member States suggests that reductions in government spending tend to provide a more durable approach to deficit reduction. After the Stability and Growth Pact has successfully supported Member States in the reduction of the excessive deficits, the functioning of its preventive part should support Member States in eliminating deficits altogether in order to deal with the looming challenges. Following the orientations of the Eurogroup on fiscal policy would mean

that most euro area members would achieve their medium-term budgetary objectives in 2008 or 2009 and all of them should aim for 2010 at the latest.

**16. *Securing sound public finances will help euro-area members to address the economic implications of ageing populations.*** Dramatic changes in the demographic structure of European populations mean that the old age dependency ratio is expected to increase from 25% at present to more than 50% by 2050 in most Member States. Some of them have already taken significant action to address this challenge. If the necessary measures are not taken soon, ageing will have a substantial budgetary impact in several euro area countries. Age-related public expenditure in the euro area, which includes spending on pensions, healthcare and long-term care, is projected to increase on average by around 4% of GDP by 2050 under a no-policy change scenario. This underlines the need for all Member States to achieve and maintain sound budgetary positions over the long-term in order to reduce significantly debt ratios and contain the subsequent projected increases in expenditure. This need is particularly acute in Member States, such as Greece and Portugal, which run the risk of posting double-digit increases in age-related public expenditure over the next decades.

**17. *Safeguarding the long-term sustainability of public finances in the euro-area requires a three-pronged policy approach.*** Firstly, Member States should, as already noted, step up efforts to consolidate their fiscal positions and meet their medium-term budgetary objectives under the Stability and Growth Pact. Secondly, the implementation of further structural reforms under the Lisbon Strategy will help to foster higher productivity growth and job creation thus countering the economic impact of ageing populations. Thirdly, reforms to pensions and health care systems and investment in improving years of life spent in good health have the potential to improve government finances over the long term.

**18. *Ensuring the quality of public finances is also important, as recognised in Member States' National Reform Programmes and the EU's Integrated Guidelines for Growth and Jobs.*** A key challenge for Member States is to meet budgetary targets while ensuring that tax and expenditure systems promote an efficient allocation of resources. Adapting tax structures and directing government expenditure towards items such as education and R&D can increase productivity growth and growth potential and bring important social and economic benefits in terms of innovation and human capital accumulation. Such policies can also help to put Member States' public finances on a more sustainable footing and improve the functioning of social models within the euro area.

**19. *Political commitments to sound public finances should be reflected in national budgetary rules and institutions.*** Research shows that Member States with well-designed numerical expenditure and revenue rules usually maintain a stronger grip on government borrowing. As discussed in this year's Annual Report on the Euro Area, Member States should, when designing these rules, pay careful attention to their coverage and the stabilisation function of fiscal policy. Effective fiscal institutions at the national level also have a role to play. For instance, parliamentary budget committees can support the conduct of sound fiscal policies and, thus, reinforce the preventive arm of the Stability and Growth Pact.

#### **IV. SECURING SUSTAINED ECONOMIC GROWTH**

**20. *As the euro area reaps the fruits of the Lisbon Strategy, it must also sow the seeds of further structural reform.*** As emphasised by EU leaders at this year's Spring European Council with the adoption of specific recommendations for the euro-area, the Lisbon economic reform agenda is critical for boosting growth and jobs in all 27 Member States but it has an added dimension for the countries that share the single currency. In the first place,

economic reforms will reduce inflationary bottlenecks in the euro area and help to sustain the economic recovery. In addition, well-functioning product, labour and capital markets are essential for ensuring a smooth adjustment to country-specific economic disturbances under EMU.

**21. *The slow adjustment of some euro-area members to country-specific disturbances is proof that economic reforms need to go further.*** A comprehensive study of adjustment by the European Commission finds that although the process of competitiveness adjustment in the euro area is dynamically stable, some Member States are adjusting too slowly to country-specific developments. This slow competitiveness adjustment has contributed to the persistence of cross-country growth and inflation differences in the euro area, thereby exacerbating the costs of policy inaction at the national level.

**22. *The Internal Market is indispensable not only for the economic prosperity of the EU but also for the smooth functioning of EMU.*** A dynamic and mature Internal Market can potentially encourage a closer alignment of national business cycles and speed up the adjustment of prices and wages to economic shocks. A key priority for euro-area and EU Member States alike is to ensure that the Internal Market is equipped to meet the opportunities and challenges of the 21<sup>st</sup> Century. When the Single European Act entered into force 20 years ago, a fairly homogenous European economy was strongly reliant on the mass manufacture of standardised products. In today's world of globalisation, new technologies and EU enlargement, an increasingly heterogeneous European economy is more and more reliant on knowledge-based and service sectors with a greater degree of product differentiation.

**23. *At the request of EU leaders, the European Commission has prepared a vision paper which calls for the single market to adapt to new realities.***<sup>1</sup> The crux of the Commission's argument is that to deliver more tangible benefits for European citizens, entrepreneurs, workers and consumers the single market needs to go beyond measures to tackle cross-border legal obstacles to business. Today's policies to deepen the single market must be more impact-driven, more effective and more globally-oriented. The Commission will present a full review of the single market with concrete proposals for policy action in the autumn.

**24. *In the area of financial market, the euro area should ensure leadership in stepping up the pace of integration at EU level, adding to the impetus already given by the euro.*** Euro-area members have a particular need for financial integration as a means of boosting growth potential and facilitating adjustment to economic shocks. The Member States that share the single currency are now already benefiting from highly integrated markets for derivatives, corporate bonds and money. The project to create a Single Euro Payments Area (SEPA) will also enable consumers, companies and other economic actors to make and receive payments in euro, whether between or within national boundaries under the same basic conditions, rights and obligations, regardless of their location. Further integration would provide more opportunities for cross-border risk sharing and favouring a more efficient allocation of resources across the area. Areas where progress should be sought include for example cross-border clearing and settlement transactions, euro-denominated government bond and bills markets – still segmented on the supply side – and mortgage markets at the wholesale (i.e. funding) and retail level.

**25. *The Commission's White Paper on Financial Services Policy in 2005-2010 provides a road map for further financial market integration in the EU and euro area.*** A timely and

---

<sup>1</sup> 'A Single Market for Citizens', Communication from the Commission to the Council, the European Parliament, the European Economic and Social Committee and the Committee of the Regions, Interim Report to the 2007 Spring European Council, Brussels, 21.2.2007, COM(2007) 60 final.

coordinated implementation and rigorous enforcement of the various legislative measures of the EU Financial Service Action Plan at the Member State level is of a considerable importance. There is also a need for continuous consultations, ex-post evaluation of existing EU policies and rules and impact assessments for new proposal. Alongside these measures, further efforts will be required, *inter alia*, to ensure that EU supervisory arrangements are well adapted to an integrated European financial market from the perspective of efficiency and stability.

**26. *Labour-market reforms are bearing fruit in terms of employment and participation, but more can be done to facilitate adjustment in relative wages across sectors, promote labour participation and facilitate sectoral and geographical mobility.*** Flexibility-enhancing labour-market reforms, heightened global competition and a reduction in the oil intensity of production and the strength of the euro exchange rate are among the factors that may have altered the process of wage formation in the euro area. This development notwithstanding, wage moderation remains essential for, *inter alia*, prolonging the economic recovery, anchoring inflation expectations and facilitating competitiveness adjustment.

**27. *In the area of product market reform, euro-area members have also made progress but there is a need to further enhance competition, innovation and dynamism.*** The adoption of the Services Directive in December 2006 is a major achievement. Ensuring its rapid implementation is a key priority and the euro area would benefit from coordinated efforts to achieve this goal. In its assessment of Member States' National Reform Programmes for Growth and Jobs, the Commission noted that all euro-area members had taken steps to promote better regulation and encourage R&D and the diffusion of innovation but called for more ambitious measures to tackle low productivity in the services sector. Further steps to enhance competition, including by better exploiting the potential of public procurement, and improvements to the business environment (e.g. access to financing, restrictive employment protection legislation) would allow consumers to benefit more widely from productivity gains and the best performing firms in the euro area to grow rapidly. Innovation is another area where there is a need to focus efforts. The challenges in high tech sectors and the persistent innovation deficit require the creation of a truly competitive Internal Market for services and an Internal Market for innovation. A clearer and more efficient Intellectual Property Rights system is currently lacking and the European Research area is still too fragmented.

**28. *Following the Commission's proposal to establish a new Energy Policy for Europe, EU leaders agreed at this year's Spring European Council on targets to combat climate change and boost energy security and competitiveness.*** These goals will be reinforced by, *inter alia*, further efforts to create a true internal market for energy and gas and the development of a common external policy approach in support of energy policy. The EU's new energy policy, while paramount for all EU Member States, is relevant for the euro-area in view of possible implications for, *inter alia*, current-account and price developments.

## **V. INCREASING GLOBAL INTERDEPENDENCE**

**29. *The euro area is part of an increasingly interdependent global economy.*** A notable development in 2006 was the euro's rising value against key trading partners. Over the year, the euro appreciated by around 11% against the US dollar and around 12½% against the Japanese yen. This strong performance has continued in the early months of 2007, leading in effective terms the exchange rate of euro area to just above its long-term level. Exchange rates should reflect economic fundamentals and excess volatility and disorderly movements in exchange rates are undesirable for economic growth. In emerging economies with large and

growing current account surpluses, especially China, it is desirable that their effective exchange rates move so that necessary adjustments will occur.

30. ***Widening global imbalances are a warning sign for the global economy.*** For the year as a whole, the US current account deficit widened to USD 857 billion, the largest in its history. In Japan, emerging Asian economies and oil exporting economies in the Middle East, current account surpluses continued to increase. China's global current-account surplus increased to USD 238.5 billion, exceeding its record in 2005. The euro-area's current account is close to balance but Europe would not be immune from the effects of a disorderly unwinding of global imbalances. Global imbalances remain an important challenge, and while they are showing some signs of stabilising, helped by some rebalancing of domestic demand growth, ensuring their orderly correction remains a priority. This will be important to avoid potential risks to financial stability and to minimise the risk of protectionist reactions.

31. ***There is a now a broad consensus among policy makers on how to tackle the problem of global imbalances.*** This has emerged as the outcome of the multilateral consultation process launched in April 2006 by the IMF, in which the euro area has actively participated along with four other major global players. This process of consultation on global imbalances has delivered positive outcome and the IMF should continue to monitor progress. The actions that key participants have agreed to implement are (i) increased national saving in the USA with measures to reduce the budget deficit and promote private saving, (ii) further structural reforms in Japan, including fiscal consolidation; (iii) greater exchange rate flexibility in a number of surplus countries in emerging Asia, in particular China, (iv) efficient absorption of higher oil revenues in oil-exporting countries, and (v) implementing structural reforms to sustain the growth potential and boost domestic demand in the euro area. The euro area is demonstrating its commitment to press ahead with further structural reforms. The priority now is for the other relevant actors to implement the agreed policy agenda in a timely manner in line with the IMF's multilateral and bilateral consultations.

## **VI. PROJECTING A STRONG VOICE ON THE GLOBAL STAGE**

32. ***Since last-year's Annual Statement on the Euro Area, several steps have been taken to improve the external representation of the euro area.*** EU Finance Ministers have asked EU Member States' IMF Executive Board Representatives to elect a longer-term chair. Details of these recommendations have been agreed upon but are not yet implemented. It was also agreed to appoint a Commission official in the office of a euro area IMF Executive Director, but, here too, implementation has not been achieved yet. Furthermore, the EU and Member States have agreed to support the Commission's participation in the G7 on all items within its competence. Euro area representatives, including the Commission, have also participated in all phases of the IMF multilateral consultation during the last year and euro area common positions and terms of references have been developed prior to the G7 and IMFC meetings.

33. ***Further steps are needed before the euro-area's external representation is commensurate with its growing weight in the global economy.*** A stronger external representation would also allow the euro area to show leadership on issues of its competency, such as global imbalances. While the best option for representation of the euro area in the key international financial fora and institutions remains the creation of a single euro-area chair, there are obstacles to achieving this in the short term, due, in part, to divisions among Member States. Building on the Communication, "Europe in the World", the Commission will continue to contribute actively to the development of develop common positions on the crucial issue of external representation.

34. ***Global governance also needs to take greater account of emerging market economies and least developed countries.*** This was reflected by the quotas-and-voice reform package agreed at the Annual Meetings of the IMF of Singapore in September 2006, which led to an increase of quotas for China and other emerging market economies. The discussion is now continuing on further reforms and representation at the IMF and the World Bank. Together with the euro area's ambition to speak with a single voice, the economic rise of the key emerging market countries is likely to act as a powerful wind of change for the international financial system.

35. ***The euro area is fostering closer macroeconomic and regulatory cooperation with new partners as well as with existing ones.*** Last year, the European Commission's annual macroeconomic and regulatory dialogue with the Chinese Ministry of Finance was complemented by a new dialogue with the Chinese National Development and Reform Commission. The regular dialogues with Japan continued and a new macroeconomic and financial regulatory dialogue with the Russian Government was held in 2006, reflecting the growing importance of Russia as a strategic partner of the EU. A new regular macroeconomic dialogue between India and the EU is also scheduled to begin this year. New macro-economic dialogues with Brazil and South Africa are also being explored to take into account of the role these countries pay in their respective regions and their strategic partnership with the Union and the euro area.

## **VII. PROMOTING EFFECTIVE AND LEGITIMATE POLICY MAKING**

36. ***To meet shared economic challenges, euro-area countries need an effective system of collective governance.*** In this respect, the Eurogroup plays an increasingly important role in promoting a common understanding among euro-area members of shared policy challenges. Over the last twelve months, the Eurogroup has, with input from the Commission, sought to deepen its consensus on structural reform challenges and other matters relevant for the euro area, as highlighted by the euro-area recommendations in the context of the Integrated Guidelines for Growth and Jobs. Some progress has been made towards improving the coordination of economic policies, as witnessed by the adoption of public orientation for budgetary policies and the increased attention to the coherence of macroeconomic policies and structural reforms. The goal now should be to turn this common understanding into concerted policies to meet these challenges and maximise the benefits of the single currency. A clearer propensity by Member States to engage in cooperative solutions may help policy discussions.

37. ***The effectiveness of policy making in the euro area is important but so too is its legitimacy.*** Mindful of this goal, the European Commission stands ready to participate in, and contribute to, the European Parliament's proposed dialogue on the key challenges facing the euro-area economy. The Annual Report on the Euro Area contributes to this understanding by presenting an analysis of the economic situation in the euro area, macroeconomic policy developments, structural-reform challenges and the external dimension of EMU.

38. ***As EMU approaches its 10<sup>th</sup> anniversary, the European Commission will devote increasing attention to evaluating the functioning of EMU and identifying ways to maximise the potential of the euro-area economy.*** A range of issues are relevant here including how well-equipped euro-area economic governance is to meet current and future challenges and whether policy makers at the European and national level can do more to achieve a policy mix that is conducive to higher growth and employment.

## VIII. CONCLUSION

39. *Policy makers should seize the opportunity created by the euro-area's renewed economic vigour to secure sound public finances and push through further structural reforms.* The Annual Statement on the Euro Area has highlighted the most salient challenges for the euro area at this juncture. In the fiscal domain, Member States must resist the temptation of fiscal loosening by intensifying efforts to meet and maintain their medium-term budgetary objectives and improving the structure and quality of public finances. Putting the Eurogroup's recent orientations on fiscal policy into practice will be very important to complete the consolidation at the level of the euro area as a whole, further strengthening the credibility of budgetary authorities, and benefiting the fiscal-monetary policy mix. In the structural domain, Member States are benefiting from past policies but further reforms are indispensable for enhancing the smooth functioning of EMU and boosting long-term living standards. At the global level, the euro-area has taken steps over the last year to strengthen its external representation in international institutions and fora and to foster macroeconomic dialogues with strategic economic partners, also with a view to addressing global imbalances. Further steps will be necessary, however, before the euro area can truly speak with one voice on international economic issues.





# **Annual Report on the Euro Area - 2007**

A report by the Commission services

SEC(2007) 550

[http://ec.europa.eu/economy\\_finance/publications/european\\_economy/2007/euro\\_area2007\\_en.htm](http://ec.europa.eu/economy_finance/publications/european_economy/2007/euro_area2007_en.htm)

# Acknowledgements

This report was prepared in the Directorate-General for Economic and Financial Affairs under the direction of Klaus Regling, Director-General. Executive responsibilities were attached to Servaas Deroose, Director for the Macroeconomy of the euro area and the EU.

The principal contributors were Alfonso Arpaia, Joaquim Ayuso Casal, Carsten Brzeski, Jeannette Capel, Björn Döhring, Roland Eisenberg, Olivia Galgau, Laura Gonzalez Cabanillas, Oskar Grevesmuhl, Ulrich Jochheim, Martin Larch, Karolina Leib, Aurora Maria Mordonu, Laurent Moulin, Anja Naujokat, Moises Orellana Pena, Dario Paternoster, Mujtaba Rahman, Valérie Rouxel-Laxton, Heliodoro Temprano Arroyo, Michael Thiel, Georges Tournemire, Errikos Velissaratos, Magnus Vesterlund, Lucio Vinhas de Souza, Joachim Wadefjord, Pavlina Zaková and Marcin Żogała. Marcin Żogała, Georges Tournemire and Wilhelm Schöllmann had special responsibility for Chapter 1, 2 and 3 respectively.

The report benefited from comments by staff of the Directorate General for Economic and Financial Affairs, including John Berrigan, Giuseppe Carone, Declan Costello, Adriaan Dierx, Elena Flores Gual, Fabienne Ilzkovitz, Jose Eduardo Leandro, Jan Host Schmidt, Massimo Suardi and Peter Weiss.

Statistical assistance was provided by Danila Conte.

Secretarial support was provided by Françoise Briard.

Jeannette Capel and Joost Kuhlmann edited and coordinated the production of the report.

Directorate-General for Economic and Financial Affairs  
Economy of the euro area and EMU  
European Commission  
B-1049 Brussels

or by e-mail to [joost.kuhlmann@ec.europa.eu](mailto:joost.kuhlmann@ec.europa.eu)



# Contents

<b>SUMMARY.....</b>	<b>vii</b>
<b>1. MACROECONOMIC DEVELOPMENTS AND POLICIES.....</b>	<b>1</b>
1.1. Macroeconomic developments .....	1
1.2. Monetary policy and developments .....	5
1.3. Fiscal policy and developments .....	8
1.4. Conclusions.....	14
<b>2. A DYNAMIC, SMOOTHLY FUNCTIONING EMU .....</b>	<b>17</b>
2.1. Economic adjustment in the euro area remains sluggish.....	17
2.2. First lessons from the euro area's adjustment process .....	20
2.3. Recent improvements in adjustment capacity .....	22
2.4. Completing financial market integration .....	26
2.5. Product market reforms remain necessary.....	28
2.6. Wage developments and competitiveness adjustment .....	33
2.7. Conclusions.....	36
<b>3. THE EXTERNAL DIMENSION .....</b>	<b>37</b>
3.1. The euro's exchange rate and global imbalances.....	37
3.2. The euro as a global currency .....	40
3.3. China, India and Russia – key economic powers .....	42
3.4. Projecting a strong voice on the world stage.....	46
3.5. Conclusions.....	48

## List of tables

Table 2.1	Contribution to productivity growth	20
Table 2.2	Price dispersion in the euro area	29
Table 2.3	Entry and exit of companies in selected countries	30
Table 2.4	The elasticity of wages with respect to expected inflation	34
Table 2.5	Growth in real wages (RW) and labour productivity (LP) across cycles	35
Table 3.1	Major currencies' share in gross issuance of international debt securities	41
Table 3.2	Currency shares in foreign exchange reserves	42
Table 3.3	Trade relationships between euro-area and China/India/Russia	44
Table 3.4	Foreign Direct Investment between the euro area and China/India/Russia	44
Table 3.5	External representation of the euro area: an overview	47

## List of graphs

Graph 1.1	Contribution to GDP growth, euro area	1
Graph 1.2	The euro-area labour market	3
Graph 1.3	Headline and core inflation, euro area	5
Graph 1.4	ECB minimum bid rate and 3-month market rate	5
Graph 1.5	Euro exchange rates	5
Graph 1.6	Real interest rates in the euro area	6
Graph 1.7	Retail interest rates in the euro area	6
Graph 1.8	Monetary developments in the euro area	6
Graph 1.9	Contributions to euro-area HICP inflation	7
Graph 1.10	Fiscal policy stance in the euro area	8
Graph 1.11	Current structural balance and medium-term objective (MTO)	9
Graph 1.12	Change in the structural balance of euro-area Member States	9
Graph 1.13	Number of numerical fiscal rules in force in the euro-area Member States	12
Graph 1.14	Statutory base of fiscal rules at different levels of general government	12
Graph 1.15	Enforcement mechanisms of numerical fiscal rules in force	13
Graph 1.16	Relation between numerical fiscal rules and budgetary outcomes	13
Graph 1.17	Cyclical behaviour of primary government expenditure	14
Graph 2.1	Annual GDP growth in the euro area	17
Graph 2.2	Inflation dispersion for euro-area Member States HICPs	18
Graph 2.3	Current account balances for selected euro-area Member States	18
Graph 2.4	Labour productivity in the euro area (country breakdown)	19



Graph 2.5	Labour productivity in the euro area (7-sectors breakdown)	19
Graph 2.6	Total factor productivity in the euro area (country breakdown)	20
Graph 2.7	Potential patterns of adjustment in a monetary union	21
Graph 2.8	Structural indicators earmarked for the Growth and Jobs strategy	23
Graph 2.9	Actual and trend labour productivity growth, euro area	25
Graph 2.10	Cross-border holdings of debt securities issued by euro-area residents	27
Graph 2.11	Proportion of variance in local equity returns explained by euro-area and US shocks	27
Graph 2.12	Standard deviation of euro-area government bond yield spreads	28
Graph 2.13	Euro-area Product Market Regulation indicators	32
Graph 2.14	Research and Development and innovation performance	32
Graph 2.15	Launching of new goods and services in national and EU markets	32
Graph 2.16	Wage indicators in the euro area	33
Graph 2.17	Unit labour costs in the euro area	33
Graph 2.18	Real effective exchange rate developments	34
Graph 2.19	Relative unit labour cost elasticity to output gap in the manufacturing sector	35
Graph 2.20	Relative wage elasticity to output gap in the total economy	35
Graph 3.1	Changes in EUR bilateral rates	37
Graph 3.2	Euro-area real effective exchange rate	38
Graph 3.3	Central bank policy rates	38
Graph 3.4	Evolution of current account balances	39
Graph 3.5	International debt securities, amounts outstanding (stocks)	40
Graph 3.6	Currency shares in the foreign exchange market	41
Graph 3.7	GDP growth rates of China, India and Russia	42
Graph 3.8	Degree of openness of China, India and Russia	42
Graph 3.9	Foreign exchange reserves of China, India and Russia	43
Graph 3.10	Current account balances of China, India and Russia	43

## List of boxes

Box 1	Slovenia – The thirteenth euro-area Member State	2
Box 2	The economic consequences of a slowdown in the US economy	4
Box 3	Country-specific experiences with adjustment in EMU	22
Box 4	The euro-area fiche: assessment of reforms in euro-area Member States	24
Box 5	Energy policy and the euro area	31





## SUMMARY

This 2007 issue of the Annual Report on the Euro Area explores in depth the common economic challenges facing euro-area members.

**Macroeconomic developments and policies** (Chapter 1): In 2006 GDP grew strongly by 2.7%, up from 1.4% in the previous year. Domestic demand strengthened significantly, reflecting a much better performance of labour markets. Close to two million jobs were created and unemployment sank to a 15-year low. Despite pressure in energy prices up to August 2006, inflation remained contained at close to 2%. Against this background, the ECB continued normalising interest rates. Services inflation remains the largest and most persistent component of core inflation. Hence, measures that address low productivity growth and limited competition in the services sector are likely to reduce overall inflation and support monetary policy. With respect to fiscal policy, there was an improvement in the euro-area's fiscal deficit (1.6% of GDP in 2006, compared to 2.5% in 2005). The benign economic conditions and the stronger-than-expected revenues have not been fully exploited to step up consolidation. Best practices from Member States show that fiscal institutions and appropriately designed fiscal rules can make a significant contribution to healthy fiscal policy and successful consolidation.

**A dynamic, smoothly functioning EMU** (Chapter 2): Persistent growth and inflation differences and continuing large current account imbalances in some Member States indicate that adjustment within the euro area is sluggish. Country experiences provide useful insights into the important role in the adjustment process of the competitiveness channel, notably that this channel has not always worked optimally due to sluggish wage and price responsiveness. Real interest rates, fiscal policies and financial markets also play a key role in a country's adjustment process. Experience shows that it is important to pay attention to the interaction of all these different elements to avoid unduly large swings in output and employment. The Commission's Annual Progress Report (APR) noted in its euro-area fiche that Member States have undertaken positive steps to foster growth and employment. However, Member States seem to be insufficiently aware of the euro-area dimension in planning their structural reform. This chapter discusses in more depth what role financial market integration, product market reforms and appropriate wage developments could play in smoothing the adjustment process.

**The external dimension** (Chapter 3): In 2006 the euro's real effective exchange rate appreciated by 3.5% in 2006, while bilateral movements vis-à-vis the US dollar and the yen were more pronounced. Global current account imbalances widened further in 2006. Given the risks this poses to the global economy, the IMF launched multilateral consultations on this issue. The euro has emerged as the second-most important international currency behind the US dollar. Given the increasing global role of the euro area, the institutional arrangements for its external representation remain inadequate although some improvements have been made recently. Furthermore, the EU's economic relationships with China, India and Russia are flourishing, making the macroeconomic dialogue and other forms of cooperation with these countries increasingly important.







# 1. MACROECONOMIC DEVELOPMENTS AND POLICIES

1. ***Economic activity in the euro area gained momentum in 2006.*** The strengthening recovery triggered adjustment of macroeconomic policies. This chapter describes macroeconomic developments in 2006 and discusses some challenges that the euro area is confronted with at the macroeconomic level. Section 1.1 sets the scene, describing economic developments last year. Section 1.2 takes up issues of monetary policy. It presents monetary developments during 2006 and looks into services inflation in more detail. Turning to fiscal policy, section 1.3 starts with fiscal developments over the last year. Subsequently, consideration is given to factors that contribute to successful consolidation. The last section concludes.

## 1.1 MACROECONOMIC DEVELOPMENTS

2. ***On 1 January 2007 the euro area welcomed its thirteenth member: Slovenia.*** Slovenia is the first of the ten Member States that joined the EU on 1 May 2004 to enter the euro area. After it reached a high degree of nominal convergence (as assessed by the Commission and the ECB<sup>1</sup>) the Ecofin Council allowed Slovenia to adopt the euro as from 1 January 2007.

3. ***The year 2006 saw a significant acceleration in economic activity in the euro area.*** Following fairly weak growth in the early phase of this cyclical upswing, GDP grew by 2.7%, up from 1.4% in 2005. This was the best

performance since 2000 and is clearly above the long-term average.

4. ***Domestic demand was the main factor driving the remarkable growth performance.*** After a sustained period of sluggishness, domestic demand picked up, reflecting buoyant investment spending and a turn-around in household spending (Graph 1.1). The former, which was rather subdued in the initial stages of the cycle, finally reached levels comparable to previous recoveries. This reflected favourable financing conditions, reduced spare capacity, and upbeat business confidence against the background of an improving outlook for growth.

Graph 1.1: Contribution to GDP growth, euro area

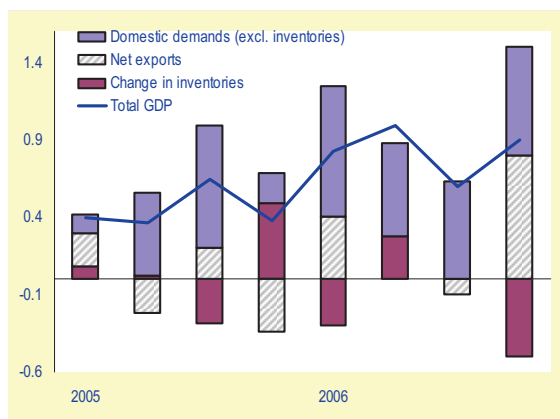

Source: Commission services.

<sup>1</sup> European Commission (2006), 'Convergence Report 2006 on Slovenia', May 2006; European Central Bank (2006), 'Convergence Report', May 2006.

## Box 1: SLOVENIA – THE THIRTEENTH EURO-AREA MEMBER STATE

1. **Slovenia has achieved a high degree of nominal convergence with the euro area.** Average inflation declined to 2.5% in 2006. The general government deficit has stayed below 3% since 2002 and the debt has stayed slightly below 30% of GDP. During its participation in ERM II since June 2004, the tolar exchange rate stayed close to the central parity. The short-term interest rate differential *vis-à-vis* the euro disappeared by the end of October 2006. The spread for long-term interest rates has been close to zero since spring 2006.

2. **Slovenia's economy has converged rapidly to the euro area also in real terms.** In 2006, Slovenian GDP per capita in Purchasing Power Standards (PPS) reached 79% of the euro area. Slovenia has maintained robust growth at around 4% since 2004, which accelerated to 5.2% in 2006. Labour productivity in Slovenia – now at approximately 75% of the euro-area average – is growing rapidly. Slovenia's labour market situation compares favourably with that of the euro area: Slovenia's employment rate is above the euro-area average (66%) and its unemployment rate is lower (6.1%).

3. **The euro brings considerable benefits to Slovenian economy.** The euro strengthens macroeconomic stability in Slovenia, which is a pre-condition for long-term economic growth and job creation. Slovenia also benefits from low interest rates in the euro area, which support investment and consumption. The lack of transaction costs and exchange-rate risk is beneficial for households and businesses: it is now easier and cheaper to travel and do business abroad, but it also makes Slovenia a more attractive trading and investment partner. This is a significant advantage as the Slovenian economy relies heavily on imports and exports.

4. **The advantages of the euro are accompanied by policy challenges.** Firstly, the euro-area's common monetary policy calls for alternative adjustment mechanisms to safeguard competitiveness in the face of asymmetric economic shocks. Wage flexibility and high labour productivity growth are important in this regard. Secondly, fiscal policy plays an important role in a monetary union since sound public finances create sufficient room for the automatic stabilizers. In the longer term, sustainable public finances are crucial in view of the costs of an ageing population. Moreover, in a catching-up economy as Slovenia additional challenges might occur. It has to be ensured therefore that rapid real convergence associated with high credit growth and price-level convergence do not interfere with price stability and do not endanger Slovenia's competitiveness.

Slovenia: convergence to the euro area (Index euro area=100)	Recent macroeconomic performance, Slovenia (annual percentage change)			
		2004	2005	2006
<p><i>Source:</i> Commission services.</p>		GDP growth	4.4	4
		Inflation	3.7	2.5
		Current account deficit (% of GDP)	-2.6	-2
		Budget balance (% of GDP)	-2.3	-1.4
				-1.6

5. **Slovenia is a small open economy.** Slovenia contributes 0.4% to euro area GDP and 0.6% to its population. This Annual Report aims to include Slovenia in the euro area aggregates – also for the years before 2007 – wherever possible.



5. **Private consumption gathered pace last year, benefiting from solid labour market performance.** The initially weaker development of private consumption compared to previous recoveries mirrored employment growth, which remained sluggish for several quarters after the turn-around in economic activity in mid-2003. In addition, wage growth remained subdued for a prolonged period in some euro-area Member States, particularly in Germany. This was welcome as a means to restore competitiveness. However, it also acted as a break on the growth of household income and, thereby, on private consumption. In 2006, however, employment growth picked up significantly and contributed to a much more robust expansion of private consumption both by increasing the number of people in employment and by strengthening consumer confidence.

6. **Two million new jobs were created in the euro area in 2006.** After moderate employment growth since 2002 the situation in the labour market improved considerably in 2006. Employment growth accelerated to around 1.5% in 2006 in the euro area, yielding an increase of close to 2 million new jobs. Since the introduction of the euro more than 10 million jobs have been created in the euro area, more than in the USA over the same period. In 2006 the unemployment rate dropped and reached 7.3% in March 2007 (Graph 1.2), the lowest level in 15 years. While the fall in the unemployment rate is largely attributable to the strong cyclical upswing, available estimates also point to a clear fall in the structural rate of unemployment.<sup>2</sup> It is currently estimated at around 7.8%, suggesting that earlier labour market reforms are starting to bear fruit.

7. **Exports contributed positively to GDP growth last year.** Notably, in the fourth quarter exports grew very strongly across euro-area countries. As a result, net exports were the main contributor to euro-area growth in the last quarter of 2006. The impact of the appreciation of the euro during 2006 on euro-area export growth was thus fairly contained. This happened in spite of a slowdown in the economic activity of some key trading partners over the last year, particularly the USA, and seems to be due to a

large extent to the broadening of world growth and the concomitant shift in the geographical composition of euro-area exports. In particular, the euro area's trade exposure to the USA has declined in recent years and as a result the direct effect from the US slowdown remained limited (see Box 2).

Graph 1.2: The euro-area labour market

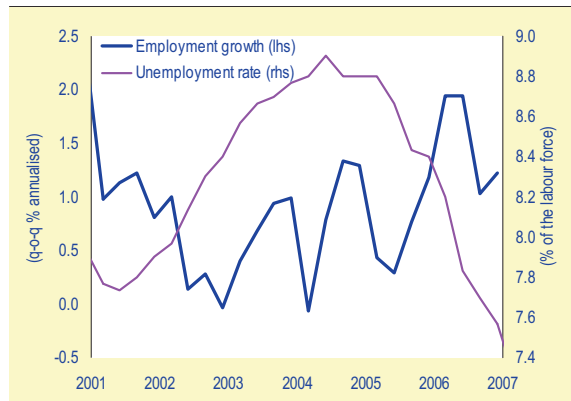

Source: Commission services.

8. **Summing up, in 2006 the euro area witnessed a clear pick-up in economic activity.** While this reflects the strengthening of the cycle, some indicators suggest that structural improvements may also be under way. This is, for instance, the case for developments in labour productivity (see Chapter 2) and estimates of the structural rate of unemployment.

9. **Economic prospects for the euro area appear to be promising.** The strong and broad recovery in 2006 bodes well for 2007. Downside risks to the outlook seem to have diminished over the last year and the external environment is more supportive than expected. However, domestic demand, i.e. private consumption and investment, show most momentum and are expected to be the main driver of the ongoing recovery in 2007.<sup>3</sup>

<sup>2</sup> The structural rate of unemployment reported here is based on DG ECFIN estimates of the NAWRU (the Non-Accelerating Wage Rate of Unemployment).

<sup>3</sup> More information on the outlook can be found in the economic forecasts published by the European Commission in spring and in autumn each year ([http://ec.europa.eu/economy\\_finance/publications/euro\\_pean\\_economy/forecasts\\_en.htm](http://ec.europa.eu/economy_finance/publications/euro_pean_economy/forecasts_en.htm)).

### Box 2: THE ECONOMIC CONSEQUENCES OF A SLOWDOWN IN THE US ECONOMY

1. *The US economy is going through a temporary dip.* Signs of a slowdown in the US economy have become evident in the course of 2006. The slowdown has its origin in the housing sector. The outlook for the US economy depends crucially on the speed at which the housing sector will cool down and on how strong the spill-over effects to the rest of the economy will be. So far, the slowdown has not affected other parts of the economy. Consumer spending is held up by wage and employment growth and supported by the recent fall in energy prices. Therefore, the risk of a "hard landing" in the USA appears low at the moment.

2. *The US impact on the euro area goes beyond the direct trade effect.* Euro-area exports to the USA will be directly affected by a US slowdown. But because of the size of the US economy and the global role of the US dollar, there will also be an indirect trade effect. The economies of third countries will be affected by the US slowdown and euro-area exports to these countries might suffer as a result. Finally, the magnitude of the trade channel effects depends strongly on the responses of exchange rates to lower demand from the USA. In case of a depreciation of the dollar, the negative effect of a US slowdown on the euro-area economy via trade effects would be higher. However, the importance of the US market for the euro-area economy has decreased over time, reflecting the growing importance of the recently-acceded Member States, oil-producing countries and Asia (see table).

**Table: Geographical distribution of euro-area exports of goods (%)**

	2000	2002	2004	2006
<b>Industrialised non-EA</b>	55.6	54.2	51.1	47.8
DK, SE, UK	25.1	24.6	23.8	21.7
USA	17.2	16.9	14.9	14.4
Other (1)	13.3	12.7	12.4	11.6
<b>EU-11 (2)</b>	14.5	15.3	16.7	18.5
<b>Candidate countries (3)</b>	3.1	2.7	3.4	3.5
<b>CIS (4)</b>	2.4	3.4	4.2	5.1
<b>Dev. Countries</b>	24.3	24.4	24.6	25.1
MENA (5)	7.4	7.9	7.9	7.6
Sub-Saharan Africa	2.7	2.7	2.6	2.8
Latin America	5.0	4.3	3.8	4.2
Asia	9.2	9.5	10.2	10.5

(1) Japan, Canada, Norway, Switzerland, Iceland, Australia, New Zealand.

(2) 2004 and 2007 accession countries excluding Slovenia.

(3) Croatia, Turkey, Former Yugoslavian Republic of Macedonia.

(4) Commonwealth of Independent States.

(5) Middle East and North Africa.

Source: IMF.

3. *A US slowdown would also have spill-over effects through corporate and financial linkages.* The US activities of euro-area companies are considerable. A lower profitability of US affiliates would have an adverse effect on the balance sheets of the euro-area parent companies. This is likely to have an additional dampening effect on investment in the euro area. A reassessment of global risks, a shift in preferences of international investors and other financial linkages could also have an impact through financial asset prices. A stronger-than-expected slowdown would likely lower the value of US assets, including those held by euro-area companies and households. This would dampen investment and consumption in the euro area.

4. *However, lower import prices and interest rates may mitigate the impact of the US slowdown on the euro-area economy.* First, lower world demand growth will reduce global price pressures, thereby reducing import prices. This will impact real incomes, profit margins and the monetary policy. Second, a decline in the growth of domestic demand in the USA will lead to higher global savings, thereby exerting downward pressure on interest rates, supporting domestic demand in the euro area.

5. *There are a number of reasons why a US slowdown would have a more limited effect on euro-area growth now than in 2001-2003.* First, the slowdown in the USA has this time not been sparked by a common adverse shock as was the case in 2000-2001 (the dot-com bubble burst). Second, the relative importance of the USA for euro-area exporters has declined. Third, the slowdown in the USA is mainly affecting the construction and housing sector, while the import demand of investment goods should hold up comparatively well. Fourth, euro-area growth is expected to be increasingly based on domestic demand in the coming years. Favourable financing conditions, good employment growth and higher profitability all point to continued solid growth of domestic demand. Finally, structural reform efforts in past years may have contributed to stronger potential growth and thereby also to the resilience of the euro-area economy to external shocks.



## 1.2. MONETARY POLICY AND DEVELOPMENTS

10. **Despite a surge in energy prices, inflation remained contained.** Increasing energy prices kept headline HICP inflation above 2% until August 2006. Since then, the substantial drop in oil and energy prices in the subsequent months helped to bring inflation down below 2%. For the year as a whole, headline HICP inflation averaged 2.2%, unchanged from the previous year. In contrast, core inflation (HICP excluding energy and unprocessed food prices) remained fairly steady throughout the year at about 1.5%, suggesting the absence of significant second-round effects from the energy price hikes (Graph 1.3). This is all the more significant as it took place in a situation of cyclical acceleration and strong labour demand.

Graph 1.3: **Headline and core inflation, euro area**  
(Harmonized Index of Consumer Prices)

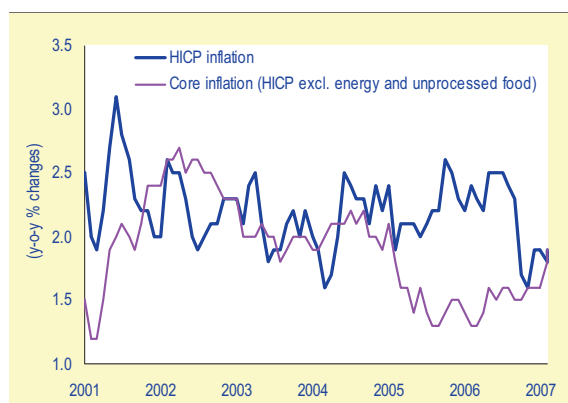

Source: Commission services.

11. **The gap between core and headline inflation narrowed in 2006.** Between late 2001 and end-2004 headline and core inflation stayed at a comparable level. From late 2004 onwards, the difference widened on the back of the fall in core inflation components, in particular non-energy industrial goods inflation and processed food inflation. In mid-2005 headline inflation rose sharply, pushed by the oil price hikes, and brought the gap between headline and core inflation to around 1 percentage point. Only in the course of 2006 did the gap narrow reflecting a sharp fall in headline inflation but also a slight rise in core inflation. Services inflation continues to make the highest and most persistent contribution to core inflation (for more discussion on services inflation see below).

12. **The ECB continued raising interest rates in 2006.** Since December 2005, the ECB's Governing Council has increased interest rates seven times, by a total of 175 basis points, to presently 3.75%. The last rate hike was decided in March 2007 (Graph 1.4). These decisions were motivated by upside risks to price stability, identified in both the economic and monetary analyses.

Graph 1.4: **ECB minimum bid rate and 3-month market rate**

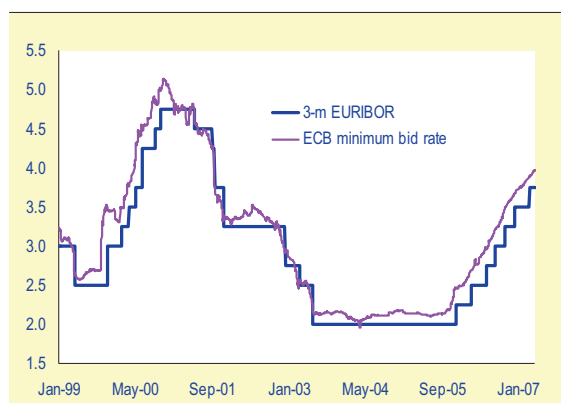

Source: Commission services.

13. **Monetary conditions in the euro area tightened somewhat last year.** This was driven by the above-mentioned policy rate increases and the appreciation of the real effective exchange rate of the euro by around 3.4% in 2006. The appreciation was even more accentuated in nominal terms against major currencies (Graph 1.5). Exchange rate developments are discussed in more detail in Chapter 3.

Graph 1.5: **Euro exchange rates**

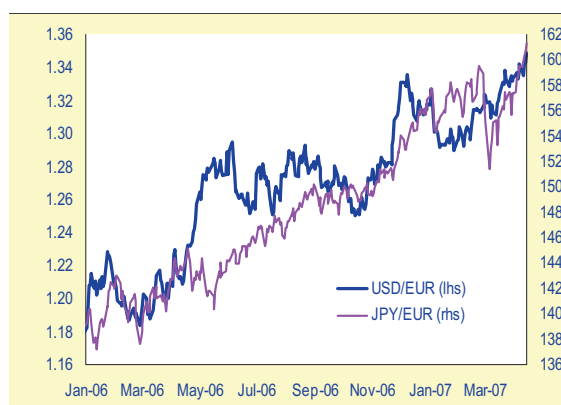

Source: Commission services.

## Annual Report on the Euro Area

Graph 1.6: Real interest rates in the euro area

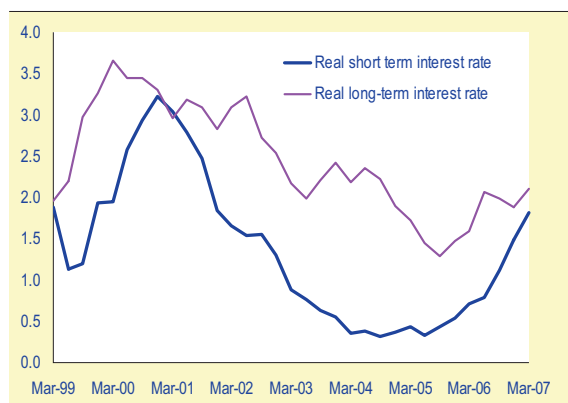

Source: EcoWin, Commission services.

14. *Despite recent interest rate hikes, both real and nominal interest rates are still at low levels* (Graph 1.6). The short-term interest rate is slowly approaching a level that might be considered to be neutral. Although the calculation of the neutral interest rate is associated with a high degree of uncertainty, most academic studies find a level between 2% and 3% for a real short-term neutral interest rate in the euro area. Recent analyses even suggest that the natural (real) rate in the euro area might have declined to slightly below 2%.<sup>4</sup>

Graph 1.7: Retail interest rates in the euro area

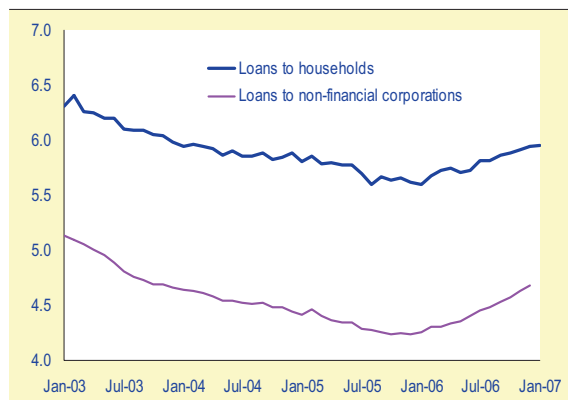

Source: Commission services.

15. *Other factors also point towards continuing favourable monetary and financing conditions.* Although long-term interest rates climbed up throughout 2006, they are still at relatively low levels. Hence financing

conditions remain favourable. Retail long-term interest rates both for households and companies increased only slightly in 2006 (Graph 1.7). Moreover, money and credit growth remain strong, and liquidity in the euro area is still ample by all plausible measures (Graph 1.8).

Graph 1.8: Monetary developments in the euro area

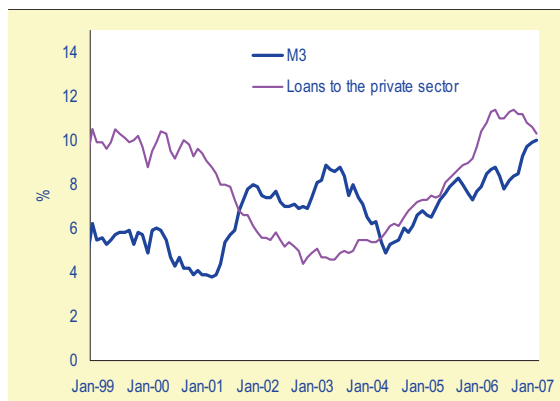

Source: Commission services.

*More competition in services will lead to lower inflation.*

16. *Services inflation has a high impact on overall consumer inflation.* The overall Harmonised Index of Consumer Prices (HICP) can be decomposed into its components to show price dynamics in different sectors of the euro-area economy. Energy inflation is by far the most variable component followed by unprocessed food. This explains why these two components are excluded in measures of core inflation. The other three components show more stability (Graph 1.9). Of these core components, services inflation has consistently made the highest contribution to overall inflation since 1999. Inflation in the services sector is in general higher than that in other sectors and is also higher than headline inflation. To some extent this can be explained by temporary factors such as reforms in health-care services or the rise in transportation costs due to oil price rises. However, the permanent character of higher inflation in services shows that structural factors are at work as well.

<sup>4</sup> For an overview of recent studies on the neutral interest rate, see European Commission (2006), *The EU Economy 2006 Review*, European Economy No. 6 2006, p. 126.



Graph 1.9: Contributions to euro-area HICP inflation  
(Annual percentage changes)

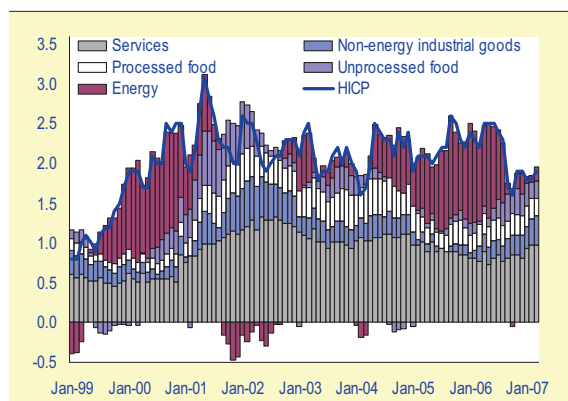

Source: Commission services

17. **Services inflation is also persistent and contributes to inflation dispersion in the euro area.** Services inflation is not only the highest but also the most persistent component of the HICP. Microeconomic research confirms that prices of services are stickier and adjust more slowly than prices of goods.<sup>5</sup> At the country level, it has also been found that the services-industry inflation differential is correlated with the overall HICP inflation differential vis-à-vis the euro-area average.<sup>6</sup> This means that countries with relatively high services inflation also tend to have overall inflation above the euro-area average, and vice-versa. This suggests that services inflation is an important contributor to inflation differentials among euro-area countries.

18. **Slow productivity growth in services is the main cause of the high services inflation.** For instance, productivity growth in industry averaged 2.3% and only 0.2% in services between 1999 and 2005. This can in part be explained by the need for a face-to-face relationship between providers and consumers of many services, and less scope for technological change than in other sectors. Wages, meanwhile, have tended to equalise among sectors. Different productivity growth and similar wage growth have led to higher unit

<sup>5</sup> See Altissimo, F., M. Ehrmann and F. Smets (2006), "Inflation persistence and price setting in the euro area. A summary of the IPN evidence", ECB Occasional Paper, No. 46.

<sup>6</sup> See Task Force of the Monetary Policy Committee of the European System of Central Banks (2006), "Competition, productivity and prices in the euro area services sector", ECB Occasional Paper, No. 44.

labour costs in services and higher inflation in comparison to other sectors (see Chapter 2). The slow productivity growth in euro-area services stands out especially in comparison with the United States. It is widely recognised that the United States' productivity boom in the 1990s had its roots in the surge in productivity growth in the services sector, mainly in retail and in wholesale trade (see also section 2.1). The US experience also shows that the intrinsic slow productivity growth in services can be overcome.

19. **The limited competition in a number of service industries exacerbates the situation.** Besides the above-mentioned factors, the lack of competition is another explanation for weak productivity gains and price rigidity in a number of service industries. Many service sub-sectors are much less exposed to international (or even inter-regional) trade and foreign competition than goods. Many service sub-sectors are also still subject to overly constraining regulations. Restrictions on competition tend to reduce pressures to innovate and to put in place more effective production processes (see Chapter 2).

20. **Completion of the single market in services is important.** The services sector is the largest sector in the euro-area economy. It represents around 70% of GDP and employment. More than 40% of consumers' expenditure is spent on services. Moreover, services also provide an important input for other sectors of the economy. Yet, despite their overwhelming importance in the euro-area economy, the completion of the single market in services has lagged behind. For instance, much progress can still be made in the area of public procurement. The problem of insufficient competition in services has been recognised by Member States, with the Lisbon Strategy calling for more competition in services markets and a fully operational internal market for services. This is also the aim of the new Services Directive (see Chapter 2).

21. **Competition-enhancing measures would help to reduce services inflation and overall inflation.** By removing unnecessary regulatory restrictions at both state and regional levels, services markets would function better. National competition authorities need sufficient powers and resources, to monitor and prevent collusion, abuse of dominance and anticompetitive

## Annual Report on the Euro Area

mergers on services markets and, perhaps, to review the impact of services legislation on competition. Consumer protection laws and powers also have a role to play. Since wage rigidities are an important determinant of price stickiness in services, higher labour market flexibility and more wage differentiation between sectors would help keep wage developments aligned with productivity growth. The example of the USA suggests that more could be done to boost productivity in services. The spread of new technologies, in particular ICT, in services could improve productivity and thereby lower inflation in the sector. As explained in Chapter 2, a better functioning services market would not only contribute to low inflation, but would also raise the euro area's capacity to adjust to shocks.

### 1.3. FISCAL POLICY AND DEVELOPMENTS

#### 22. *Revenue surprises contributed to a fall in the fiscal deficit for the euro area as a whole.*

In 2006 the nominal budget balance in the euro area improved. The deficit stood at 1.6% of GDP, down from 2.5% in 2005. This mainly reflected buoyant economic growth that led to better-than-expected budgetary revenue. The revenue-to-GDP ratio increased to 45.8% – higher than expected in early 2006. The level of budgetary expenditure was essentially stable but the expenditure-to-GDP ratio fell to 47.4% because of higher GDP growth.

#### 23. *The current buoyancy of tax revenues has gone hand in hand with a sharp rise of tax elasticities.*

Tax elasticities were well below their average in the past economic slowdown. Their current rise reflects a number of factors such as a steep recovery of corporate profits, rising oil prices, a recovery of tax-rich domestic consumption expenditure, a positive performance of equity markets and, in some countries, -rising house prices.

#### 24. *The fiscal stance was broadly neutral in 2006.*

The fiscal policy stance can be approximated by changes in the cyclically-adjusted primary balance (CAPB) that shows the budgetary correction net of cyclical factors and interest payments. 2006 saw a broadly neutral stance after a moderate tightening in 2005. In 2006 the CAPB increased slightly, by 0.3%, which falls short of the 0.5% benchmark

improvement envisaged for "good times" by the revised Stability and Growth Pact. The consolidation effort was also much lower than in 2005 in spite of the much better economic situation (Graph 1.10).<sup>7</sup>

25. *In some countries there is a risk of a pro-cyclical policy.* The slower pace of fiscal adjustment in the euro area stems mainly from the deterioration of structural balances in countries that have already achieved their medium-term objectives (MTO). Given the good economic performance, a looser fiscal stance might result in pro-cyclical fiscal policies in those countries and contribute to overheating of the economy. Moreover, the structural adjustment in 2007 is expected to remain below 0.5%, suggesting that Member States do not take full advantage of the current good economic conditions.

Graph 1.10: Fiscal policy stance in the euro area

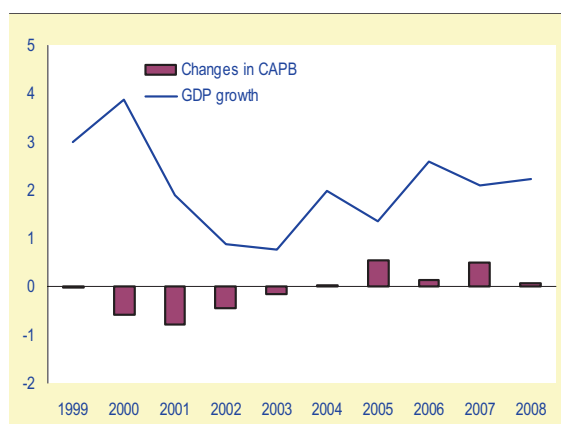

Note: Commission forecasts for 2007 and 2008 data.

Source: Commission services.

#### 26. *There are worrying similarities between the current situation and the past recovery.*

The current configuration of rapid economic growth and positive surprises in tax revenue closely resembles the situation that prevailed at the turn of the decade. Major policy mistakes were made then. In 1999-2001, several Member States did not make use of the good economic conditions to achieve healthy public finances. These countries subsequently found themselves in an uncomfortable position when the cycle entered a less favourable phase. The absence of budgetary margins to let automatic stabilisers

<sup>7</sup> Graph 1.10 up to Graph 1.12 (and references in the text to the figures presented there) are based on the interim economic forecasts. New data will be available in May 2007.





operate resulted in either a breach of the reference value, or pro-cyclical fiscal policy, or both. The inappropriate fiscal stance of those years has been widely recognised as being at the roots of the difficulties with the implementation of the original Stability and Growth Pact.

**27. The policy mistakes of 1999-2001 should be avoided.** It is essential that the spirit of the 2005 SGP reform be upheld in the current benign economic environment. The revised Pact contains clear provisions on the need to strengthen consolidation efforts when growth conditions are favourable, with particular reference to tax revenue. In such periods, Member States which have not yet reached sound fiscal positions are expected to strive for significant improvements in their structural balance.

**28. Currently, four euro-area Member States have excessive deficits: Germany, Greece, Italy and Portugal.** On 30 January 2007, the Council decided that the excessive deficit procedure against France should be closed as its budget deficit remained below 3% also in 2006. In Germany, the economic recovery has helped to bring the budget deficit below 3% of GDP one year ahead of schedule. In Greece, there has been a strong correction in 2006 which has led the budget deficit to remain at 2.6% of GDP. Portugal and Italy have also recorded a significant structural improvement in 2006, masked in the case of the latter by the effect of one-off measures.

Graph 1.11: Current structural balance and medium-term objective (MTO)

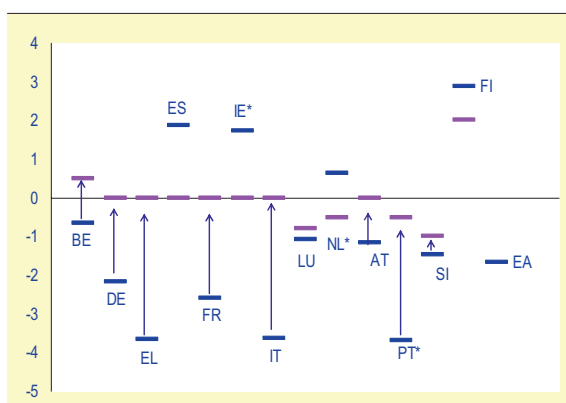

**Note:** Ireland has an MTO of "close to balance", the Netherlands has an MTO "between -0.5% and -1% of GDP" and Portugal has an MTO of "at least -0.5% of GDP"

**Source:** Commission services.

**29. Most Member States have set their MTOs at levels consistent with the principles of the reformed Stability and Growth Pact.** Some countries have set more ambitious targets, exceeding the minimum levels required, mainly for consistency with their national strategy to face sustainability challenges (Graph 1.11). In most Member States the current structural balances still differ significantly from the MTO. Three broad groups of Member States can be identified (Graph 1.12):

- Member States which had already achieved their MTOs recorded deteriorations in their structural balances in 2006.
- Member States with a deficit of below 3% of GDP which had not yet reached their MTOs posted a fiscal adjustment of less than the 0.5% of GDP benchmark in 2006. The adjustment effort is planned to be stepped up in 2007 and 2008.
- Member States with deficits of above 3% of GDP have, on average, planned significant consolidation efforts over the years 2006-2008.

Graph 1.12: Change in the structural balance of euro-area Member States

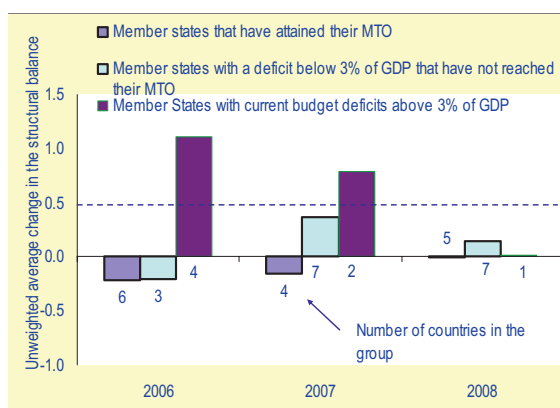

**Source:** Commission services.

**30. On 20 April 2007, the Eurogroup adopted orientations for fiscal policies in euro area Member States, recalling the commitment to actively consolidate public finances in good times and to use unexpected extra revenues for deficit and debt reduction.** With a view to improving the coordination of fiscal policies in the euro area, euro area Finance Ministers discussed national budgetary developments in 2007 and the preliminary policy outlook for

## Annual Report on the Euro Area

2008 and their implications for the euro area. Firstly, they committed to build on the better-than-expected budgetary outcomes in 2006 and to pursue more ambitious budgetary targets than those set in the 2006 Stability Programmes. Secondly, they agreed to implement budgets for 2007 as planned, avoiding expenditure overruns, and using unexpected extra revenues to reduce government deficit and debt. Thirdly, it was agreed that fiscal policy plans for 2008 should be carefully designed so as to accelerate adjustment towards the medium-term budgetary objectives for Member States which have not reached it and for those which have reached it to avoid fuelling macroeconomic imbalances.

### *Achieving successful fiscal consolidation*

31. ***Sound fiscal policy remains a necessary pre-condition for sustained growth, investment and employment creation.*** Low budget deficits and government debt foster low and stable inflationary expectations and help maintain low interest rates. Unsustainable public finances in one Member State could lead to higher interest rates and financial instability in the rest of the euro area. Hence, sound fiscal policy supports a stability-oriented monetary policy and is a prerequisite for the success of the monetary union. Against this backdrop, fiscal consolidation is essential for countries with a high deficit and a high debt level. Fiscal consolidation then also creates room for manoeuvre for the working of automatic stabilisers.

32. ***Consolidation helps to face the budgetary challenge of ageing.*** Country-specific strategies are needed to face the upcoming massive impact of ageing on public finances. Age-related public expenditure in the euro area, which includes spending on pensions, healthcare and long-term care, is projected to increase on average by around 4% of GDP by 2050 under a no-policy change scenario. This, however, masks a variety of situations across euro area Member States, with some at risk of double digit increases over the next decades. Ideally, the country-specific strategies contain measures to reduce budget deficits and debt, as well as structural reforms to face the prospective increase of expenditure items related to ageing populations (pensions, healthcare and long-term care). It is crucial that Member States that have not attained their

MTOs make rapid progress towards reaching them. In this context the present favourable cyclical conditions provide a window of opportunity of speeding up fiscal consolidation.

33. ***The success of fiscal consolidation depends on a number of factors.*** Effective fiscal consolidation can be defined as a relatively sharp improvement in a country's primary budget balance net of cyclical factors that is implemented over a given number of years. A consolidation episode is deemed to have been successful if the fiscal correction is sustained in time. Empirical evidence suggests that a number of specific factors increase the likelihood of success. The first group of factors relates to the composition of the adjustment, the economic environment and political factors. The second group relates to institutional factors such as fiscal rules.

### *Composition, economic conditions and other factors*

34. ***Expenditure-based consolidations tend to be more successful.*** One of the most important factors affecting the success rate of fiscal consolidation is its composition. The potential for a durable budgetary adjustment is typically larger when driven by restraint in expenditure than when relying on higher revenue. There is also an additional benefit in terms of economic effects. Compared to revenue-based corrections, expenditure-based consolidations tend to have a less restrictive or even an expansionary impact on the economy. Cases in point are Spain in 1996-1997, the Netherlands, and Ireland in the early and mid-1990s and Finland in the mid- and late 1990s. This can be explained by a number of factors, of which three are mentioned here:

- Spending curbs are more likely than revenue increases to trigger lower interest rates (as revenue increases may have adverse effects on costs and prices); this in turn may lead to higher consumption and investment and finally have a positive impact on real GDP growth.
- Expenditure cuts can create room for tax cuts, which in turn have beneficial



effects on wage-bargaining, investment, consumption and growth.

- Governments which tackle high expenditure demonstrate a commitment that paves the way for further substantial consolidation.

As regards the type of expenditure, adjustments that primarily rely on cuts in transfers and the government wage bill have a better chance of being successful than cuts in public investment, which are very often reversed and do not usually have any positive impact on output growth.

35. ***In practice, consolidation episodes are composed of both revenue and expenditure measures.*** When budgetary consolidation is brought about via one-off measures the chances of success are usually slim. In practice, many successful consolidation episodes involved a combination of revenue and expenditure measures. These often take the form of so-called switching strategies: the government begins the fiscal consolidation process by increasing taxes and/or cutting investment, and subsequently tackles the more politically sensitive current expenditures.

36. ***Economic factors influence the success of consolidations.*** Firstly, initial conditions play a significant role. Large initial deficits tend to prompt fiscal consolidation and are also positively correlated with the size, intensity, and length of the consolidation episode. The size of the fiscal correction is also enhanced by higher, rather than lower, interest rates. The role of economic growth is somewhat more complex. Consolidation episodes in weaker economic conditions often take longer and make only a relatively small annual correction. However, the overall improvement in the budget balance tends to be higher. In a similar vein, cautious forecasts of GDP growth (and implicitly of tax revenue) promote consolidation by reducing the probability of negative growth surprises and revenue shortfalls.

37. ***Structural reforms and political factors also play a significant role.*** Fiscal consolidation is generally more durable and hence more successful when it is accompanied by structural reforms that improve the public finances in the long run. Consolidation is boosted in situations in which both the population as a whole and all interest groups

involved fully realise the need for reforms. Thus successful consolidations and any underlying reforms are commonly supported by strong political leadership by the Prime Minister and/or Finance Minister. They are also assisted by clear communication to the public via politicians, think tanks, and the media. Painful changes are often publicly justified by reference to the objective of preserving the welfare state. A case in point was Sweden in the early and mid-1990s.

### ***Fiscal governance and fiscal rules***

38. ***Fiscal policies in industrialised countries have not always been optimal.*** The economic literature provides abundant analysis of how taxes, government expenditure and government balance should be set over the business cycle for fiscal policy to be considered optimal and sustainable. However, experience shows that policy-makers have not always acted in line with these prescriptions. This has resulted in large and persistent deficits and growing public debts. Fiscal policy has also often turned out to be pro-cyclical, particularly in good economic times, in spite of the broad agreement that a neutral or counter-cyclical stance would be preferable.

39. ***Institutional settings contribute significantly to sound fiscal policies.*** There has been growing consensus in recent years among economists and policy-makers that the sources of the “deficit bias” and the “pro-cyclical bias” in the conduct of fiscal policy are rooted in the “political economy”. They include factors such as the system of incentives and rewards that shape the behaviour of fiscal authorities.

40. ***The Council has recently emphasized the importance of strengthening fiscal governance in the Member States.*** Both the Treaty and the Stability and Growth Pact stress the importance of national rules and institutions for budgetary discipline. In its report of 20 March 2005 on the reform of the Stability and Growth Pact, the Council stated that “national budgetary rules should be complementary to the Member States’ commitments under the Stability and Growth Pact”. The Council further underlined that domestic governance arrangements should complement the EU framework, and that national institutions could play a more prominent role in budgetary surveillance.

## Annual Report on the Euro Area

41. **Various institutional elements can reduce spending and deficit biases.** First, *procedural rules* laid down in law or in the constitution govern the implementation of the annual budget law and fix the respective powers of the various actors. Second, *numerical fiscal rules*, which fix targets and ceilings for fiscal aggregates or set benchmarks for the conduct of fiscal policy, can limit the discretion of fiscal authorities that are prone to deficit bias. Third, *independent fiscal institutions* (e.g. fiscal councils) can play a valuable role by providing inputs or recommendations on fiscal policy issues.

42. **Numerical fiscal rules can play a useful role.** Such rules can be defined in many different ways. For instance, they can introduce limits on the deficit or debt of different government entities (*budget balance and debt rules*). The limits can be set on a yearly basis or on average over a given period. Alternatively, they can set benchmarks for the evolution of some categories of government expenditure (*expenditure rules*) or predefine the allocation of certain categories of tax revenue (*revenue rules*). Numerical fiscal rules can be more or less strong. Fiscal rules enshrined in the constitution or in other forms of law and subject to strict monitoring and enforcement mechanisms, can impose binding limits on the conduct of fiscal policy. While still allowing some room for discretion in policy-making, they can directly contribute to fiscal discipline. Numerical fiscal rules based on political commitments or informal agreements between different tiers of general government can also have a positive impact on the conduct of fiscal policy. Such rules provide benchmarks against which fiscal policy can be assessed by the public, and can effectively contribute to policy coordination between different levels of government.

43. **Euro-area Member States increasingly rely on numerical fiscal rules.** According to a survey conducted by the European Commission in 2005, the number of fiscal rules in force in the euro-area Member States has increased continuously over the last fifteen years (Graph 1.13). There has been an interesting evolution in the government sub-sectors covered by numerical fiscal rules. While the existence of numerical fiscal rules at local and regional level was already frequent in the early nineties, an increasing number of numerical fiscal rules has since been introduced at central government level. A relatively recent feature is the

introduction of numerical fiscal rules in the social security sector and rules covering the whole of the general government sector. Such developments may be a response to the introduction of the EU fiscal rules, which impose requirements for the general government deficit and debt, and to the increasing spending pressures in the social security sector.

Graph 1.13: Number of numerical fiscal rules in force in the euro-area Member States

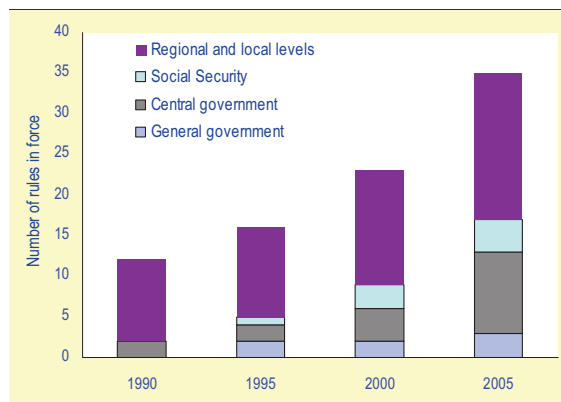

Source: Commission services.

Graph 1.14: Statutory base of fiscal rules at different levels of general government



Source: Commission services.

44. **The characteristics of the rules vary with the level of government.** According to the same survey by the European Commission, rules applied to regional and local governments generally rely on annual schemes. In contrast, rules concerning the general government and central government sectors have a longer time horizon. These rules generally play a key role in those Member States where the annual budget process is embedded in a comprehensive medium-term budgetary framework. The statutory basis of numerical fiscal rules also seems to depend on the level of government.



The large majority of numerical fiscal rules applied to local and regional levels of governments are enshrined in law or the constitution. Rules concerning central government and the whole of the general government sector are, on the other hand, generally based on forms of political agreement – e.g. internal stability pacts or other forms of political agreement or commitment (Graph 1.14)

45. **Rules applied at local levels of government generally have stronger monitoring and enforcement procedures.** A crucial characteristic of fiscal rules is the nature of the monitoring and enforcement mechanisms. Automatic correction or sanction procedures in the event or risk of non-compliance tend to favour respect of rules. Regular monitoring of compliance by an independent authority is also important. Such monitoring and enforcement procedures are, on average, applied more often at local and regional government levels than at higher levels of government (Graph 1.15). However, the apparent weaker status of the latter may be compensated by more public attention and media interest. High media visibility of a fiscal rule can be expected to contribute to its enforcement, through higher reputation costs in the event of non-compliance.

Graph 1.15: Enforcement mechanisms of numerical fiscal rules in force in 2005

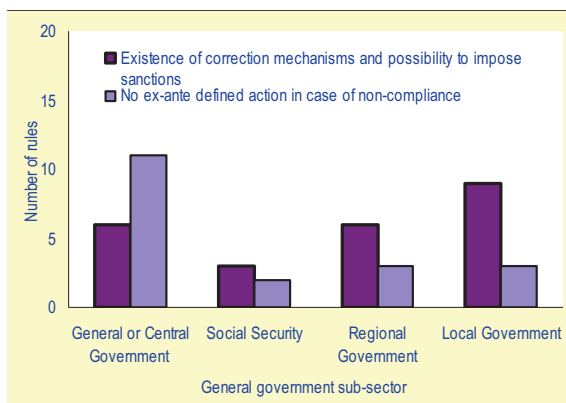

Source: Commission services.

46. **Empirical evidence suggests that a larger reliance on numerical rules can help to reduce deficits.** The European Commission's report 'Public Finances in EMU – 2006' shows that there is a relation between the size of government deficits and the reliance on numerical fiscal rules. Over the last fifteen years,

the cyclically-adjusted primary balance has on average improved in the years following the introduction of numerical fiscal rules. Another key result is that an increase in the share of government finances covered by numerical fiscal rules seems to lead, *ceteris paribus*, to lower deficits or higher surpluses (Graph 1.16). The analysis in the above-mentioned report also confirms the effectiveness of expenditure rules in addressing a possible spending bias. In particular, the decline in the ratio of primary government expenditure adjusted for the cycle was significantly larger after the introduction or strengthening of expenditure rules. In addition, the introduction of an expenditure rule helped to secure a primary balance large enough to stabilise the debt-to-GDP ratio. As for revenue rules, rules on how to use extra revenues stemming from windfall gains under cyclically favourable conditions (which could involve the setting-up of stabilisation funds) can be instrumental in achieving fiscal consolidation.

Graph 1.16: Relation between numerical fiscal rules and budgetary outcomes

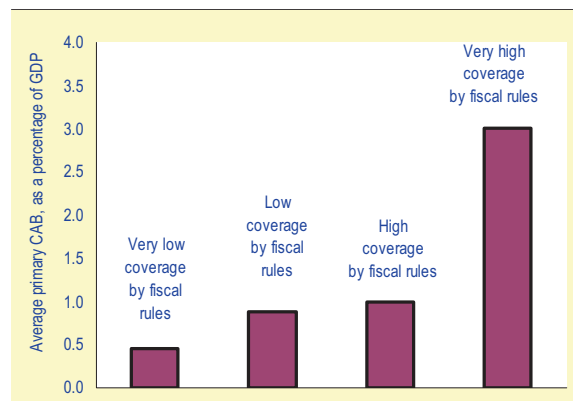

Source: Commission services.

47. **The impact of numerical fiscal rules on budgetary outcomes depends on their design.** On average, rules enshrined in law or the constitution, and provided with well-defined enforcement mechanisms that can be activated by independent authorities seem to have a greater influence on budgetary outcomes. However, other, less formal, rules can also positively influence budgetary outcomes. There are several examples of rules which are not enshrined in law or in the constitution, but are based on strong political commitments (e.g. coalition agreements), that have had a clear influence on budgetary developments and played a key role in fiscal consolidation strategies.

## Annual Report on the Euro Area

Graph 1.17: Cyclical behaviour of primary government expenditure

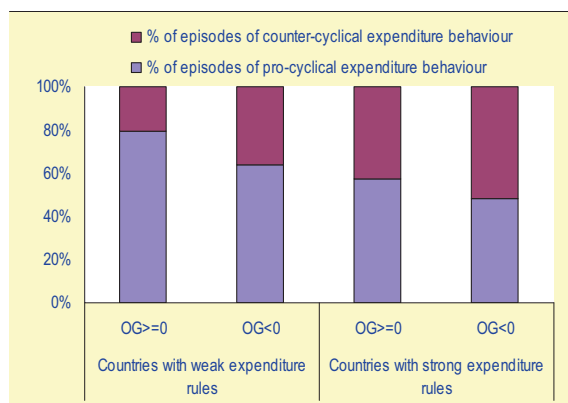

Note: OG – output gap.

Source: Commission services.

48. *The nature and design of numerical fiscal rules is also important for the cyclical behaviour of fiscal policy.* Some economists have argued that overly strict numerical rules may hamper the stabilisation function of fiscal policy. Therefore, it is crucial how rules are defined. Rules that exclude cyclically-sensitive items or that are applied "over the cycle" may actually reduce the risk of pro-cyclicality in fiscal policy. Moreover, multi-year expenditure rules or frameworks can effectively curb the tendency for expenditure to grow faster during economic good times. In the same way, "rainy-day funds" or numerical fiscal rules that pre-define the allocation of possible revenue windfalls are valuable. They can help governments to credibly commit not to spend or give away via tax cuts better-than-expected tax revenue during good times. Such rules therefore can be instrumental in avoiding pro-cyclical policies as can be seen from the empirical evidence. Countries in which numerical fiscal rules are properly designed in order not to hamper the stabilisation function of fiscal policy tend to have a more counter-cyclical fiscal stance. Empirical analysis also confirms the positive properties of expenditure rules. Pro-cyclical behaviour of expenditure in good times is less frequent in countries with strong expenditure rules (Graph 1.17).

49. *Overall, national fiscal rules can play an important role in supporting fiscal consolidation while helping avoid pro-cyclical policies.* The desirable characteristics of fiscal rules depend on domestic circumstances. There is no "one-size-fits-all" design. However, it appears that a number of features support the effectiveness of national fiscal rules. As highlighted by the Ecofin Council

in its conclusions adopted on 10 October 2006, fiscal rules, to be effective, should benefit from strong national ownership as well as from a clear political commitment by all levels of government and parliament.

### 1.4. CONCLUSIONS

50. *The euro-area economy is benefiting from a strong recovery.* The upturn is now well established and broadly based among sectors. Domestic demand picked up strongly in 2006, as private consumption was boosted by the solid performance of the labour market. Risks to the outlook are mainly on the upside.

51. *The robust recovery has made an adjustment of the policy mix appropriate.* Accordingly, the ECB has been increasing interest rates in 2006 and in the early months of 2007. Although monetary conditions have become somewhat tighter in the light of these interest rate increases and the appreciation of the euro exchange rate, monetary and financial conditions have remained favourable. Fiscal policy has been only marginally adjusted so far, with more remaining to be done in view of the still-high debt levels and the budgetary challenges of ageing. Better-than-expected revenue led to a slight fall in the euro-area's fiscal deficit and the fiscal stance became somewhat tighter. However, several Member States failed to make full use of the improved economic situation. Some countries that have achieved their medium-term objectives run the risk of procyclical policies. Moreover, some Member States that have not yet achieved their MTO failed to achieve the required structural adjustment of 0.5% of GDP. On the positive side, it is noteworthy that the largest part of fiscal adjustment in the euro area comes from Member States with excessive deficits.

52. *Measures to reduce services inflation would enhance the scope for an accommodative monetary policy.* Inflation rates came down in the last months of 2006 and are expected to remain moderate over 2007 and 2008. Services inflation continues to be the largest and the most persistent component of core inflation. This is due to low overall labour productivity growth – combined with the often high labour intensity and insufficient wage differentiation between sectors – and the barriers to competition in many services sectors.



Addressing these deficiencies would contribute to lower inflation.

53. ***Best practices from Member States show how successful fiscal consolidation is best achieved.*** Expenditure-based consolidations appear to be more successful than revenue-based consolidation. To succeed with consolidation, it also helps to create national ownership for the process and to show strong political leadership.

Institutional settings can significantly contribute to sound fiscal policies. Many euro-area Member States are successfully making use of numerical rules in their fiscal policies. When designing these rules, it is important to keep in mind: (i) how these rules can best contribute to favourable budgetary outcomes, (ii) which level of government they apply to, and (iii) how pro-cyclical outcomes can be avoided.







## 2. A DYNAMIC, SMOOTHLY FUNCTIONING EMU

54. *While a smooth adjustment to economic disturbances is of central importance to EMU, more progress is needed.* The benign economic environment provides a good opportunity to make further progress. Section 2.1 examines divergences in growth, inflation and current accounts. First lessons from adjustment in the euro area are presented in section 2.2. Section 2.3 highlights recent positive developments in structural reform under the Lisbon Strategy for growth and jobs and in productivity growth. Finally, sections 2.4, 2.5 and 2.6 look at the role of financial markets, product markets and labour markets respectively, within the adjustment process. Section 2.7 concludes.

### 2.1 ECONOMIC ADJUSTMENT IN THE EURO AREA REMAINS SLUGGISH

55. *Growth differences exhibit some persistence in the euro area.* Growth differences between euro-area Member States already existed before 1999 and have tended to persist, though not to any markedly different extent. Since 1999, annual growth in Germany, Italy, the Netherlands and Portugal has nearly always been below the euro-area growth average, while Greece, Spain, Ireland, Luxembourg and Finland consistently recorded above-average growth rates (Graph 2.1). The remaining euro-area countries grew by close to the average. These growth differences have persisted during the whole period, but narrowed somewhat in 2006 due to the strengthening of the German economy and improvements in the Italian economy. Overall, what is noticeable is that these growth differences persist, even though the euro-area countries have become much more

integrated and business cycles have become more closely aligned.

Graph 2.1: Annual GDP growth in the euro area (in %)

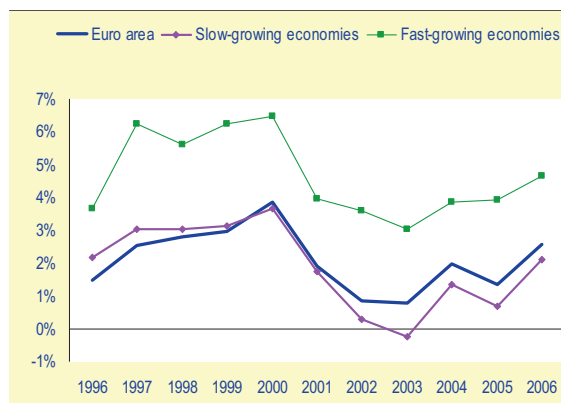

Fast-growing economies (unweighted): GR, ES, IE, LU and FI  
Slow-growing economies (unweighted): DE, IT, NL, PT  
Source: Commission services.

56. *Inflation differentials in the euro area are low but also tend to be persistent.* From a historical perspective, inflation dispersion clearly dropped in the run-up to EMU, from around 5-6 percentage points at the beginning of the nineties to less than 2 percentage points in 1999. In EMU's first two years dispersion increased somewhat, but it returned to low levels afterwards (see graph 2.2). However, inflation differences among euro-area Member States have tended to persist. Six Member States, namely Greece, Spain, Ireland, Italy, Portugal and Slovenia, were found to be persistently above the average, while the other three – Germany, France and Austria – were persistently below. Only four Member States, i.e. Belgium, Luxembourg, Finland and the Netherlands, recorded periods of both positive and negative differentials vis-à-vis the euro-area average over the period 1999-2006.

## Annual Report on the Euro Area

### 57. *Persistent differences in growth and inflation originate in a number of factors.*

Differences in growth and inflation should not be a source for concern *per se* if they reflect different positions in the cycle or if the main reason for such a divergence was a one-off event. However, there were other factors behind the persistence phenomenon in this case, the three main ones being as follows. First, initial conditions matter. The strong decline in interest rates in the run-up to EMU in some countries inflated consumption and investment such as in real estate. These developments were fuelled to a certain extent by financial exuberance and the credit cycle. Second, prices and wages were too slow to adjust to national cyclical conditions, with wage flexibility, which is conducive to the reallocation of factors of production, remaining particularly insufficient. Third, some budgetary policies were pro-cyclical and failed to achieve the necessary fiscal consolidation (see Chapter 1). As a result of these three elements, national business cycles were amplified.

**Graph 2.2: Inflation dispersion for euro-area Member States HICPs**  
(year-on-year growth in %)

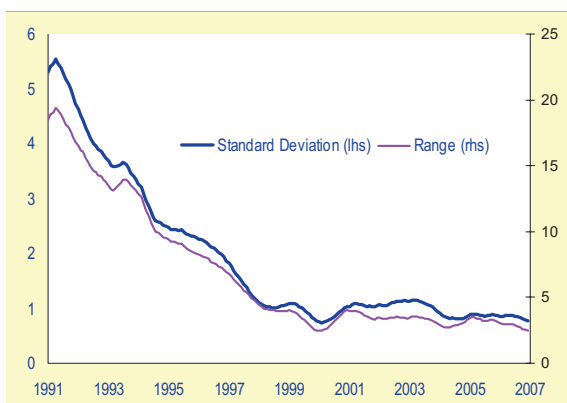

Range: distance between highest and lowest inflation performance  
Source: Commission services.

### 58. *Persistent current account differences suggest that competitiveness adjustments are slow.*

The dispersion of current account balances within the euro area has widened significantly since the late nineties. This is a result of the sharp deterioration of current account deficits in Greece, Portugal, and Spain and – to a lesser degree – of the markedly rising surpluses in Finland, Germany, Austria and the Netherlands (which have seen improvements in their current account position of respectively 5.5, 4 and 3.4 percentage points, see Graph 2.3). At the same time, the external balance of countries

already in deficit at the start of EMU did not rebound. Portugal saw no improvement in the period 1999-2006 and still records a deficit of close to 9% of GDP, and the current account position of Spain and Greece deteriorated between 1999 and 2006 by 6 and 2.8 percentage points respectively.

**Graph 2.3: Current account balances for selected euro-area Member States**  
(in % of GDP)

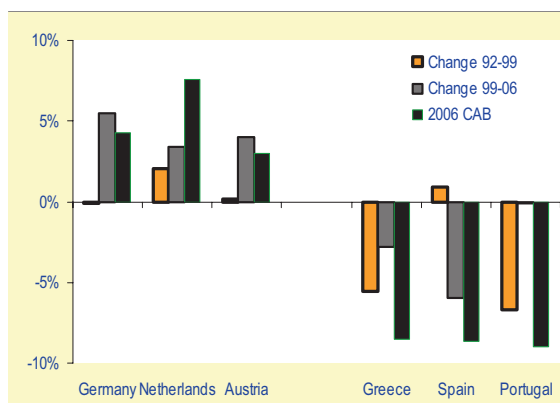

CAB = Current account balance  
Source: Commission services.

The widening dispersion of current account positions within the euro area is due to a combination of causes. Differences in cyclical positions had some impact, albeit rather modest. Deeper financial integration, mostly related to the European integration and the euro, played a stronger role. It allowed a cut in the risk premium and a loosening of credit constraints. This enlarged the borrowing capacity of the private sector in Greece, Portugal and Spain. As these three countries have lower per capita income than the euro-area average, financial deepening has made it possible to meet their potentially higher financing needs through additional foreign capital flows. A third explanation for the dispersion of current accounts stresses competitiveness changes. Although changes in competitiveness and therefore in the current account balance are needed to adjust to a shock, the extent and duration of these changes reveal some structural inefficiencies. In particular in Spain and Portugal, losses in competitiveness have been compounded by the sluggish response of wages in the face of a sharp productivity slowdown. Overall, whereas current account differences can still be reabsorbed without significant consequences in the longer term, the rebalancing process will need to be followed carefully in the



coming years from both an analytical and a policy perspective.

59. **Slow adjustment is compounded by low productivity growth.** Slower productivity growth lowers the economy's potential growth and means that the correction of an accumulated competitiveness gap takes longer. Restoring competitiveness means a downward adjustment of unit labour costs, which are determined by the evolution of nominal wages and productivity. A failure to achieve higher productivity growth thus means that nominal wages will have to bear the brunt of the adjustment.

Graph 2.4: Labour productivity in the euro area Member States  
(Average annual growth in %)

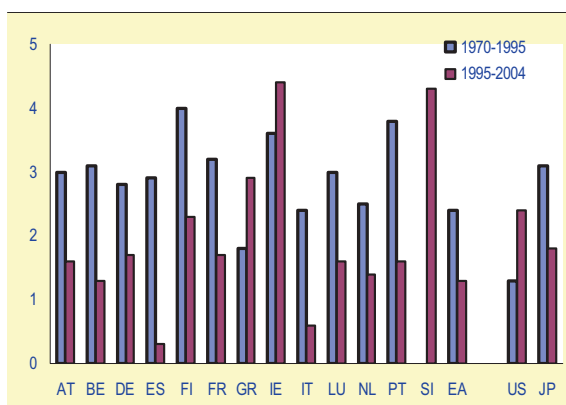

Source: Commission services and EU KLEMS database.

60. **Historical data from the new EU KLEMS database confirm weak productivity growth.**

The EU KLEMS project builds a system of analysis at the industry level for the EU Member States (as well as the US and Japan) which encompasses internationally harmonised statistics, as well as a growth accounting analytical framework.<sup>8</sup> The comparison of average growth figures from the period 1970-1995 to the period 1995-2004 indicates that labour productivity growth decelerated for all euro-area Member States except Ireland and

<sup>8</sup> This project, funded under the 6th Research Framework Programme of the European Commission, will eventually cover over 60 industries, with 25-30 countries, up to 35 years of data and between 60-70 variables and indicators included. The first results were released in March 2007. The EU KLEMS database could be accessed at: [www.euklems.net](http://www.euklems.net).

Greece.<sup>9</sup> While annual productivity growth decelerated from 2.4% to 1.3% in the euro area between the two periods, it accelerated from 1.3% to 2.4% in the United States (Graph 2.4).

Graph 2.5: Labour productivity in the euro area 7-sector breakdown  
(Average annual growth in %)

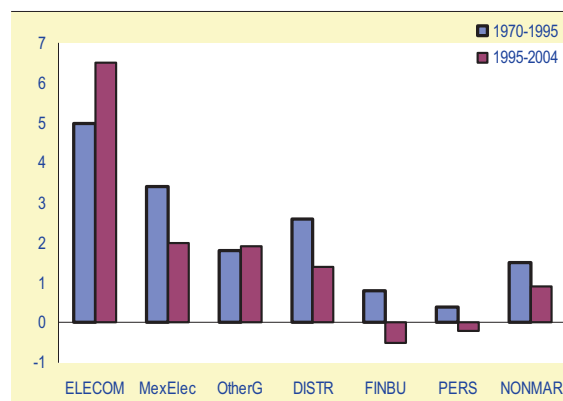

Note: ELECOM= Electrical machinery, post and communication; MexElec= Manufacturing excluding electrical; OtherG= Other goods producing industries; DISTR= Distribution services; FINBU= Finance and business services; PERS= Personal and social services; NONMAR= Non-market services.

Source: Commission services and EU KLEMS database.

61. **Wider positive spillovers from the acceleration of productivity in the high-tech sector have not been visible.**

Evidence suggests that information and communication technologies (ICT) play a significant role in the revival of productivity in advanced countries. But although productivity accelerated markedly in the ICT-producing sector<sup>10</sup> of the euro area in the 1995-2004 period, its contribution to aggregate euro-area productivity figures remained small (Graph 2.5). This is due to its low share in total output and the absence of discernable productivity spillovers to other sectors (Table 2.1). In fact, productivity decelerated in manufacturing and all services sub-sectors.

62. **Trends in total factor productivity (TFP) confirm this picture.**

TFP can be defined as the capability to combine efficiently labour and capital in the productive process<sup>11</sup>. In all euro-

<sup>9</sup> Data for Slovenia are available only from 1995 on.

<sup>10</sup> Proxied here by the ELECOM sector.

<sup>11</sup> TFP reflects the joint effects of many factors including research and development (R&D), new technologies, economies of scale, managerial skill, and changes in the organisation of production.

## Annual Report on the Euro Area

area countries except Finland and the Netherlands, the contribution of TFP to output growth has decreased (Graph 2.6). In Italy, Spain and Luxembourg TFP-growth even turned negative. Beyond these lacklustre developments, there are grounds for hope. First, some euro-area countries, such as Finland and the Netherlands, owed their better performance to a significant acceleration of TFP in the ICT-producing sector and in distribution services. Thus in these countries some form of spillover, albeit limited to one sector, may have materialised. Second, the recent rebound in productivity growth could be more than just cyclical in nature (see Section 2.3).

**Table 2.1: Contribution to labour productivity growth (in percentage points)**

	Euro area		United States	
	1980-1995	1995-2004	1980-1995	1995-2004
Total industries	2.4	1.3	1.3	2.4
ELECOM	0.2	0.2	0.3	0.4
MexElec	0.8	0.4	0.4	0.4
OtherG	0.5	0.3	0.0	0.0
DISTR	0.5	0.3	0.6	0.9
FINBU	0.0	0.0	0.0	0.4
PERS	0.0	0.0	0.0	0.1
NONMAR	0.2	0.2	0.1	0.2

**Note:** In the period 1980-1995, reallocation of labour contributes to 0.1 percentage point in the euro area and to -0.1 point in the US.

**Source:** Commission services and EU KLEMS database.

**Graph 2.6: Total factor productivity in the euro area Member States, market economy (Average annual growth in %)**

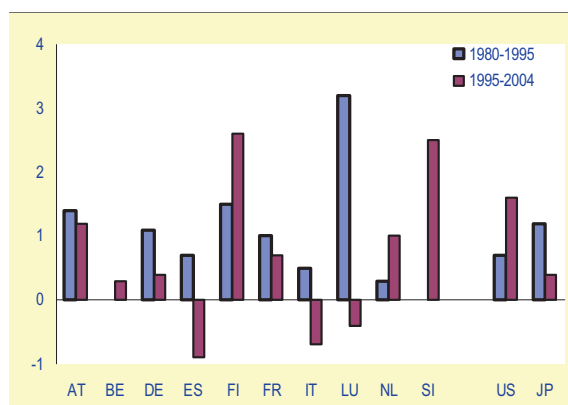

**Note:** The first period covers 1987-1995 for Belgium and 1982-1995 for France. Only the data for 1995-2004 are available for Slovenia.

**Source:** Commission services and EU KLEMS database.

## 2.2 FIRST LESSONS FROM THE EURO AREA'S ADJUSTMENT PROCESS

### 63. *The euro area has an even greater stake in successful structural reform than the EU.*

Whereas the European Union as a whole needs reforms to boost its growth potential and stimulate job creation, the euro-area, being a monetary union, should pay even more attention to such reforms as they enhance internal adjustment through market flexibility. The first years of EMU provide a number of country-specific experiences that are especially useful in this regard. Since 1999, the euro area has had to face several episodes of economic turbulences (bursting of the dot-com bubble, 9/11 terrorist attacks, high volatility of oil prices). In addition, the economic impact of the run-up to EMU had differentiated effects among euro-area Member States before 1999, and these effects persisted after 1999. All these elements enable policy-makers to better understand how the adjustment process has worked in practice and to draw tentative conclusions.

### 64. *Competitiveness is the main channel for adjustment.*

Theoretically, above-average demand in a given country should push costs and prices upwards. The deterioration in the relative cost situation should then worsen that country's cost and price competitiveness and slow the pace of economic activity towards the euro-area average. The experience of the Netherlands during 1997 to 2005 illustrates that this adjustment process has worked in practice (see Box 3 for country examples). At times of country-specific weakness the reverse would occur if real prices and wages are flexible downwards.

### 65. *However, the real-interest rate channel can complicate adjustment.*

Real interest rates in euro-area Member States tend to fall as inflation accelerates in a boom, and to increase during a slowdown. This may amplify swings in output and inflation in the short and medium term. Such effects are inherent to some degree in all monetary unions. As shifts in competitiveness get underway, real interest rates at the national level can affect the adjustment path in a perverse (i.e. pro-cyclical) direction.

### 66. *Evidence shows that adjustment in the euro area is working but could be slow.*



According to a Commission model<sup>12</sup>, the adjustment process in the euro area is dynamically stable, because the balancing effects of the competitiveness channel are stronger than the unbalancing impact of the real interest rate channel. However, the adjustment can be quick or slow. It could even led to overshooting, when corrective action is pursued beyond what is needed (Graph 2.7).

Graph 2.7: Potential patterns of adjustment in a monetary union

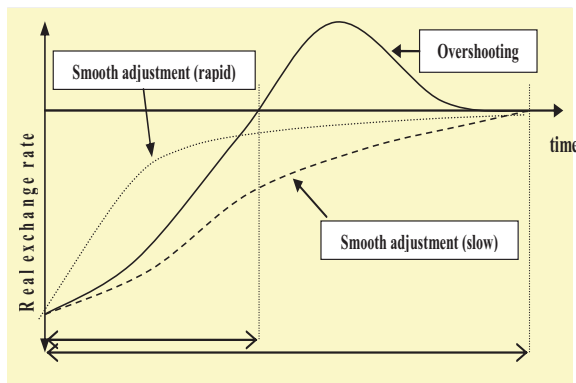

Source: Commission services.

67. *In some cases sluggish price and wage responsiveness have impaired adjustment.* Wage behaviour, taken together with underlying trends in productivity, has an important influence on the efficiency of adjustment process. Significant divergences exist in the extent to which wages and prices have responded to changes in national output gaps. Some countries have experienced sluggish wage adjustment, compounded by low downward real price flexibility. Thus adjustment through changes in competitiveness may be slow, resulting in a less efficient adjustment process and larger swings in output and employment (see section 2.6 for further analysis.)

68. *Financial markets have played an important role in the adjustment process.* Financial markets encourage risk-sharing and can help to smooth the effect of an economic shock. The decline in risk premia and the easing of credit constraints have opened up new economic opportunities, including higher scope for household borrowing. But financial markets

have not always made a positive contribution to the adjustment process. Asset markets have tended to boom as real short- and long-term interest rates declined, so that wealth effects have amplified the real interest rate channel (see section 2.4.)

69. *Fiscal policy has sometimes been pro-cyclical.* During upswings, budgetary authorities have sometimes overestimated the underlying strength of revenues, which have been boosted temporarily by a consumption-rich composition of GDP and, in some cases, asset market booms. In addition, there is a tendency to revise potential growth up too sharply, and to factor it into public sector wage agreements and budgetary projections. Therefore, some countries have failed to accelerate fiscal consolidation in "good times". As a corollary, there has been sometimes insufficient fiscal flexibility to support economic activity during the downswing.

70. *Fiscal policies and financial and labour market developments interact and jointly influence adjustment.* Individual countries' experiences show that it is important to pay attention to the potential interactions between policies and sectors in order to smooth the adjustment process. Otherwise there is a risk of pro-cyclicality, which amplifies swings in output and inflation. The experiences of Spain and the Netherlands illustrate this risk. In Spain, a fall in risk premia, a relaxation of credit constraints on households, strong migration flows and demographics heavily strained the housing market. In the Netherlands, pro-cyclical developments in financial markets, wages and the fiscal stance proved mutually reinforcing.

71. *Finally, there can be sizeable spillover effects in the euro area.* For instance, strong housing investment in large euro-area countries affects other Member States through demand effects. Inflationary pressures in one country could raise aggregate euro-area inflation and lead to a tightening of monetary conditions for the euro area as a whole. Hence, it is important for Member States to promote reforms to facilitate adjustment in the euro area in the context of the Growth and Jobs Strategy.

<sup>12</sup> European Commission (2006), "Market adjustment, the competitive channel", Chapter 4 in "Dynamic Adjustment in the Euro area: Experiences and challenges", EU Economy Review 2006.

### Box 3: Country-specific experiences with adjustment in EMU

*Germany* had a poor growth performance in the first years after the creation of the euro area. However, growth was already slow since the mid-nineties. After unification, wages increased well in excess of productivity, large overcapacities were created in the construction sector and public finances became unsustainable. As productivity growth remained low, adjustment took place through wage moderation. As strong constraints were also set on public spending, domestic demand remained muted for a decade. Competitiveness improved markedly, through lower wage increases than in the rest of the euro area. Rising current account surpluses have demonstrated the renewed strength of the German economy, while the recent revival of construction and consumer spending points to a more balanced growth mix. As a result, growth in Germany is now close to the euro-area average for the first time since 1994.

*Spain* has consistently recorded higher growth rates than the rest of the euro area. As a result, Spanish real GDP per capita rose from around 80% of the euro-area average in the mid-nineties to 90% in 2005. In the early years of monetary union, declining interest rates boosted investment, especially in the housing sector. This trend was fuelled by financial innovation and a rapid population growth. As a result, inflation increased steadily and the decline in real interest rates added to demand pressures. The current account deficit widened significantly to reach 6% of GDP. Labour market reforms, a relatively cautious budgetary policy and increased trade openness have mitigated somewhat inflationary pressures and positively influence the ongoing adjustment process.

The *Netherlands* outpaced the euro-area average growth by 1 % point in the period 1996-2000. High growth rates were fed by strong consumption and investment growth, in particular in housing. The sharp increase in housing prices and consequent wealth effects together with expansionary fiscal policy at the end of the economic boom induced some overheating. The tightening labour market exerted upward pressures on wages from 2000 to 2002, while inflation peaked at 5.1% in 2001, the highest rate among euro-area countries at the time. The cumulative increase in nominal unit labour costs between 1998 and 2003 resulted in an accumulated loss in competitiveness and a fall in corporate investment. Significant wage restraint, together with fiscal consolidation, dampened domestic demand and restored competitiveness. After three years of slower growth, GDP moved back to the euro-area average from 2004 on.

*Portugal* went through a boom in the run up to euro-area membership. Annual GDP growth exceeded 4% until 1999, driven by strong investment as interest rates fell. Because of the rising demand pressures, wage and price inflation exceeded the euro-area average in the 1990s by more than 5 and 2% points respectively. Private debt rose gradually to high levels, representing eventually 120% of households' disposable income in 2005. Competitiveness was hurt, which resulted in rising current accounts deficits. Fiscal policy in the last decade was initially pro-cyclical and thereby reinforced domestic demand pressures, whereas the subsequent fiscal consolidation limited the country's capability to smoothen adjustment. Between 2000 and 2003, a sharp downward adjustment occurred as consumption and investment slowed down considerably. Against the background of weaker productivity and increased competition in export markets from emerging countries, the external sector only provided limited support. Adjustment challenges remain.

## 2.3 RECENT IMPROVEMENTS IN ADJUSTMENT CAPACITY

### *Progress with the Lisbon Strategy*

72. *The Lisbon Strategy for growth and jobs coordinates structural reform in the European Union.* It aims to foster employment and raise potential growth in the whole Community through reforms in product markets, budgetary institutions, financial and labour markets.

Moreover, as emphasised by the European Parliament in its resolution on the situation of the European economy, the Lisbon Strategy is also essential for "strengthening innovation, technological advances and human capital accumulation, removing remaining barriers hampering the operation of the Internal Market, and creating a more conducive environment for business activities".<sup>13</sup> The fact that integrated reforms strengthen Members States' capacity to adjust to economic shocks in an economic and monetary union is an additional incentive to undertake them.

<sup>13</sup> European Parliament Resolution on the Situation of the European economy: preparatory report on the Broad Economic Policy Guidelines for 2007 (2006/2272 (INI)).



73. *Euro-area Member States have addressed many reform areas that are important to stimulate growth and jobs.* This is shown in the Annual Progress Report of December 2006 in which the Commission assesses the National Reform Programmes and Implementation Reports of the Member States. Promising reforms have been undertaken, or have been planned, to increase labour participation rates, boost R&D and innovation, develop human capital and create a more attractive business environment, notably through policies improving the quality of regulation. There have also been important steps to reinforce fiscal sustainability, with governments generally setting out measures to improve their budgetary positions and tackling projected increases in pension and health care costs.

**Graph 2.8: Structural indicators earmarked for the Growth and Jobs Strategy, euro area**  
(change in percentage points from 2000 to 2005)

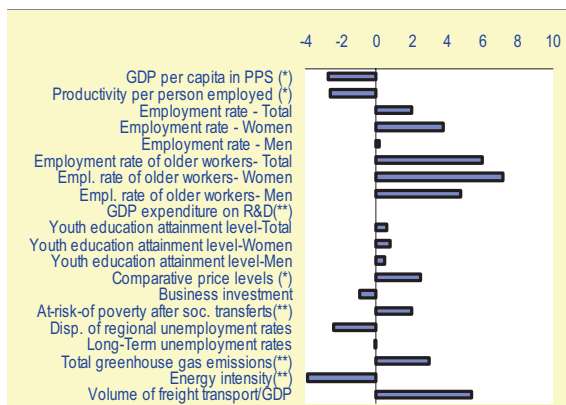

**Note:** data and methodology could be accessed on the Eurostat website (<http://europa.eu.int/comm/eurostat/structuralindicators>)  
(\*) change in relation to the EU25 average; (\*\*) 2000-2004 change  
**Source:** 2006 Commission assessment of National Reform Programmes, euro-area fiche.

74. *Structural indicators point to progress in several areas.* In particular, the employment rate in the euro area rose by 2 percentage points between 2000 and 2005 to reach 63.5% (Graph 2.8). The employment of women contributed most to this increase and reached 55.2%. However, this performance was skewed, with Spain (+7 points) and Italy (+3.9 points) accounting for the bulk of the improvement. In contrast, progress was broad-based for older workers, whose area-wide employment rate grew by 6 percentage points to reach 40.4% in 2005. The dispersion of regional unemployment rates followed the same downward trend and decreased from 12.9% in 2000 to 10.5% in 2005,

mainly due to positive developments in Spain, Italy, Greece and Finland.

75. *Further progress is needed with the structural reforms most relevant to increase the adjustment capacity of the euro area.* Therefore, the Commission has included a fiche dedicated to the euro area in its Annual Progress Report on the state of implementation of the Lisbon Strategy. The euro-area fiche focuses on reforms that are deemed especially relevant for the smooth functioning of EMU and, on the basis of a thorough dialogue with euro-area Member States, issues four recommendations to them:

- Firstly, to make use of the favourable cyclical conditions to aim at or pursue ambitious budgetary consolidation towards their medium-term objectives in line with the Stability and Growth Pact, hence striving to achieve an annual structural adjustment of at least 0.5% of GDP as a benchmark;
- Secondly, to improve the quality of public finance by reviewing public expenditures and taxation with a view to enhancing productivity and innovation, thereby contributing to economic growth and fiscal sustainability;
- Thirdly, to effectively implement measures that improve competition, especially in services, and step up measures that promote the full integration of financial markets and competition in retail financial services;
- Fourthly and finally, to improve flexibility and security on labour markets inter alia by better aligning wage and productivity developments, balancing employment protection and security in the market and enacting measures to promote labour mobility across borders and between occupations.

## Box 4: The euro-area fiche: assessment of reforms in euro-area Member States

This box presents a summary of the Commission assessment on reforms undertaken by euro-area Member States.

**Macro-economic dimension:** Progress has been made towards achieving sound budgetary positions. Sound public finances will create the necessary room to cope with fluctuations over the economic cycle and reinforce fiscal sustainability in perspective of ageing populations. The combined euro-area budgetary position should improve and the public deficit is expected to be lowered to 1.5% of GDP in 2007. The euro-area Member States with the highest budget deficits are expected to record relatively strong improvements in their structural balances in 2006 and/or 2007. During 2006, measures in the area of pension and health reform have been adopted or announced in a number of euro-area countries, including in countries considered to face a medium or high risk to the sustainability of their public finances. While progress has been made to reduce deficits, some countries need to accelerate the pace of budgetary consolidation and continue reforming pension and health care systems.

**Microeconomic dimension:** The assessment of reform efforts in the field of goods and services markets in the euro area shows signs of progress. While all euro-area countries took policy actions to promote better regulation, encourage R&D and the diffusion of innovation, the measures proposed or taken could be more ambitious in order to effectively address the challenge of low productivity growth in the services sector. In order to improve the functioning of the euro-area services markets, the adoption of the Directive on Services in 2006 represented notable progress (see below for a discussion of the Services Directive). In this respect, quick implementation is essential to enhance competition in sheltered services. Many Member States addressed competition issues in network industries (notably in the gas and electricity sector but also in electronic communications). Nevertheless, greater efforts are needed in many countries in respect of issues such as the separation of network management and supply as well as the resources and independence of the regulator. Many Member States are taking positive steps towards reform in the key area of professional services, whereas others yet need to undertake major efforts. The 2007 Internal Market Review will propose essential actions that Member States, especially euro-area countries, must take.

The single currency crucially enhanced the integration of financial markets among the euro-area Member States, but more needs to be done to exploit untapped potential. At the EU level, some initiatives of particular importance for the euro area are advancing, namely the Directive on payment services, the results of the Commission's inquiry into competition in financial services and the application of a code of conduct on clearing and settlement of securities. Some progress in the transposition of the Market in Financial Instruments Directive has been achieved in some euro-area Member States.

**Employment dimension:** The general assessment of labour market reforms is fairly positive. A number of policies were initiated in order to increase labour supply and make work pay. A number of countries have adopted further measures to increase labour supply through interventions targeted towards particular groups (women, older workers, the young, migrants, and disabled people). To make work pay, a number of countries have adopted measures to reduce income taxes. These cuts either benefited all employees or were targeted at vulnerable groups (long-term unemployed, low-wage workers, young and older workers). There is still insufficient action to enhance incentives for older workers to stay longer in the labour force. Reforms of unemployment benefit systems to promote activation measures are also insufficient. Only limited action has been taken in the area of employment protection. Most Member States made progress with the implementation of programmes to foster human capital formation. However, they mostly focused on education for the young at the expense of training for adults already in the workforce. Finally, a review of the functioning of wage setting and measures to enhance labour mobility in euro-area countries is warranted.

### Monitoring Implementation of the Lisbon Strategy - Key dates and procedures

<b>Autumn 2005</b>	Each Member State produces its <b>National Reform Programme (NRP)</b> , which defines the main national challenges in view of the Lisbon objectives, as well as the policies addressing them.
<b>Autumn 2006</b>	The NRPs are followed by annual Member State <b>Implementation Reports (IR)</b> that show where progress is made in meeting Member States' own reform strategies. The Commission submits a Technical Implementation Report on the progress with policy measures at the Community level.
<b>Winter 2005 and 2006</b>	The NRPs and subsequent annual IRs are then subject to a thorough <b>assessment</b> , first by the <b>European Commission</b> , and then by the Member States themselves. In its 2006 assessments, the Commission highlights what it considers to be the strengths and weaknesses of each Member State. A separate assessment is produced for the euro area, the so-called euro-area fiche.
<b>Winter 2006</b>	The concluding section of the Commission's assessment includes specific policy recommendations covering those areas where weaknesses need to be urgently tackled. These were <b>addressed to each Member State and to the euro area as a whole</b> . They are discussed by the Council in view of adopting a Council Recommendation on the 2007 Broad Economic Policy Guidelines (Art. 99(2)) and on the Employment Guidelines (Art 128(4)) addressed at each Member State and, concerning the euro-area fiche, at the euro-area Member States.
<b>Spring 2007</b>	





***Rebound in productivity growth: more than just cyclical?***

76. ***Higher labour productivity growth is important for the euro area.*** For many years, the euro area has been lagging behind the US in terms of productivity growth (see Section 2.1). This has led to lower potential growth in the euro area. However, higher potential growth alleviates the economic consequences of ageing. Higher productivity and economic growth also facilitate the adjustment to economic shocks. In particular, high productivity growth could reduce the need for wage restraint in adjusting to a negative competitiveness shock.

77. ***Labour productivity in the euro area surprised on the upside in 2006.*** Boosted by the acceleration of economic activity, labour productivity growth in the euro area averaged 1% last year, compared with an annual average rate of 0.7% during the previous decade. The acceleration in labour productivity in 2006 was broad-based. Within the private business sector, labour productivity growth strengthened in manufacturing industry, largely thanks to capital deepening. Labour productivity increased markedly in the private services sector. It grew by 1% in 2006 (see Graph 2.9), which constitutes a significant improvement from the previous decade (0.2%). Given the higher weight of services in GDP, the services sector contributes now as much to overall labour productivity growth as the industry sector.

78. ***Cross-country divergence of labour productivity growth was marked in 2006.*** Among the larger euro-area Member States, productivity gains in Germany have doubled (3.7%) in comparison with the average over the 1995-2005 period. Labour productivity growth in France also accelerated to 2.5%, from 1.4% on average over the previous ten years. In Spain, productivity grew by 1.1%, compared to -0.7% in the earlier period. Italy presented a less favourable picture, with labour productivity only slightly accelerating from 0.3% to 0.7% in 2006. However the Spanish and Italian figures might have been subject to temporary downward pressures due to the effect of the regularisation of immigrants on employment statistics in 2006.

79. ***Productivity usually picks up strongly in the early stages of an economic upturn and***

***tends to decelerate in a downturn.*** This pro-cyclical behaviour reflects the lagged response of employment to output changes. But labour productivity growth is also subject to long-run dynamics typically captured by trend patterns. As a key determinant of long-run economic growth, trend productivity growth (i.e. productivity growth without its cyclical component) constitutes a core economic indicator. Hence, trend labour productivity is of significant policy relevance, as it is a key variable for competitiveness, potential output and ultimately economic welfare.

80. ***A number of factors suggest that the productivity revival is not solely due to a cyclical recovery.*** The recent rise in productivity growth appears to be broad-based and also comprises sectors that are less sensitive to the business cycle such as services. Other supportive factors for a more than cyclical improvement in productivity include: the strong rise in the investment ratio in recent years, a reversal of the trend decline in total factor productivity growth, an increase in the share of productivity-enhancing ICT investment and use, and, last but not least, recent reforms in product and labour markets in the framework of the Lisbon Strategy for Growth and Jobs (see Box 4). Therefore, whilst a clear-cut decomposition of the recent acceleration in productivity growth into cyclical and structural components is difficult, the above-mentioned factors suggest that the recent rebound in labour productivity could be more than just cyclical in nature.

Graph 2.9: **Actual and trend labour productivity growth in the euro area**  
(Private business sector, in %)

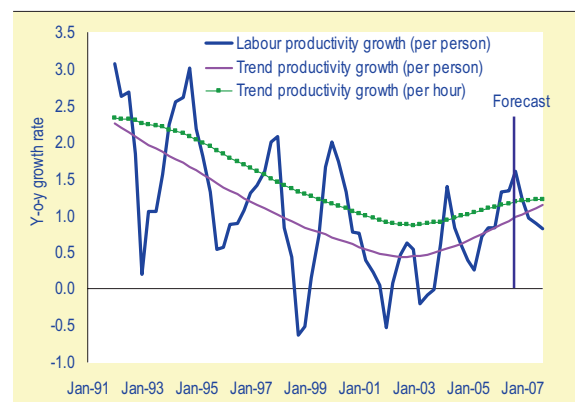

Source: Commission services.

## Annual Report on the Euro Area

### 2.4 COMPLETING FINANCIAL MARKET INTEGRATION

81. ***Financial integration creates an efficient financial system and boosts economic potential.*** The financial sector fulfils key functions that are necessary for an efficient allocation of financial resources in time and space and allows real sector activity to expand optimally. These functions include: (i) executing financial transactions safely and economically thanks to appropriate mechanisms for trading, clearing and settlement; (ii) pooling investor resources and subdividing investment opportunities, thereby overcoming mismatches of scale; (iii) effectively pricing and managing the risks related to financial transactions through providing liquidity; (iv) reflecting available information efficiently in prices; and (v) addressing possible information asymmetries and conflicts of interest in the financial intermediation process. To the extent that the financial sector is constrained in the performance of these various functions, there is a consequent cost in terms of sub-optimal economic performance and welfare loss.

82. ***Financial integration also raises a region's capacity to cope with economic shocks.*** With well-integrated financial markets, the euro area would be less vulnerable to external shocks, while a regional shock – originating within the euro area – would be diffused and thereby diluted more easily. Moreover, financial integration creates new opportunities for cross-border diversification of portfolios. Such reallocation reduces home bias, promotes risk-sharing and increases the overall capacity of the financial system to bear risks. On the other hand, integration increases contagion risk so that a local financial disturbance can propagate rapidly across the entire financial system. This could be a risk for financial stability if the procedures for crisis prevention, management and resolution remain segmented on a national basis, making area-wide responses more difficult. In this context, improved co-operation among the relevant national authorities is essential to ensure that the financial-stability arrangements keep pace with financial-market innovations. Finally, empirical evidence for the United States reveals that financial markets play a non-negligible role in smoothing the macro-economic cycles. Better-

integrated financial markets within the euro area could do the same.

83. ***The euro has provided a major impetus to financial integration in the EU.*** The process of EU financial integration has accelerated markedly since the introduction of the euro. The euro has created large and liquid financial markets in which financial intermediaries can reap the benefits of larger economies of scale and scope. Before the introduction of the euro, the need for market participants to operate in national currencies was a major obstacle to an integrated financial system. The presence of currency risk limited the attractiveness of cross-border financial activity, thereby restricting competition between the domestic markets of the Member States. However, the elimination of currency risk has also shifted attention to the need to remove remaining obstacles to financial integration, linked to differences in national regulation, supervisory practices, laws and taxation (see below).

84. ***The global trend in financial innovation also helps financial integration.*** In particular, credit derivatives make it easier for financial institutions to rebalance their exposure to national or sectoral credit risk. This is done by issuing synthetic credit risk transfer such as collateralised debt obligations that are backed by diversified assets. This market has grown considerably over the last few years. Although precise data for the euro area are not available, such innovative products promote market completeness and have the potential to spread risk more evenly over the euro area.

85. ***The Financial Services Action Plan (FSAP) removed many remaining obstacles to an integrated financial market.*** The FSAP, which was launched in parallel with the introduction of the euro, comprises 42 legislative and non-legislative measures, of which 40 have been adopted, relating to both wholesale and retail financial markets. For example, the FSAP facilitates EU-wide capital-raising (through the Prospectus Directive), sets common standards for financial reporting (e.g. the Regulation on International Accounting Standards) and promotes investor confidence and market integrity (e.g. through the Market Abuse Directive). Recent measures include action to



improve the inter-operability of national clearing and settlement systems (through a code of conduct on clearing and settlement) and establishing common rules for securities and derivatives markets (through the Market in Financial Instruments Directive, also known as Mifid). The measures contained in the FSAP have now been largely adopted at the EU level and the latest legislative measures must now be transposed into national law.

Graph 2.10: Cross-border holdings of debt securities issued by euro-area residents (in %)

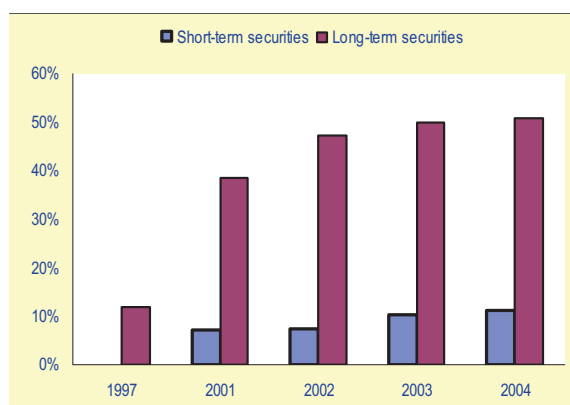

Note: share of debt securities issued by euro-area residents and held by residents (excluding central banks) in other euro-area countries. 1997 data for short-term securities is not available.  
Source: European Central Bank.

86. **Financial integration progressed over the last few years.** For instance, monetary financial institutions<sup>14</sup> have strongly increased their cross-border holdings of debt securities issued by government and corporations from other euro-area countries (their share rose from 15% in 1997 to 40% in 2006, see Graph 2.10.) Euro-area investment funds have also strongly increased their euro-area cross-border holdings (from 23% in 1999 to 47% in 2005). As regards equities, the ECB measured the proportion of domestic equity returns that can be explained by local and common factors<sup>15</sup>. Common factors included euro area-wide and US shocks. Over the past thirty years, national stock market returns have been increasingly driven by common shocks, with the share of the variance explained by euro-area common shocks rising more strongly (from 6% to 38%) than the US-related variance (from 10% to 15%). This points to growing regional

integration, although local factors remain important for equities (Graph 2.11).

Graph 2.11: Proportion of variance in local equity returns explained by euro area and US shocks (in %)

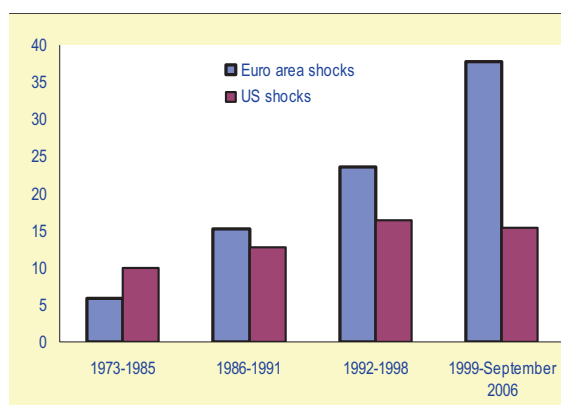

Source: European Central Bank.

87. **But financial market integration is not yet complete.** Wholesale markets tend to be better integrated than retail markets, but the pace of integration has also varied across different market segments. The *euro-area money and derivative markets* are now substantially integrated. The market for interbank short-term debt and deposits is highly integrated, with interest rates in participating Member States determined by EONIA (Euro Overnight Index Average) and EURIBOR (Euro Inter-Bank Offered Rate). The euro-area derivatives market is making progress towards integration with a sharp expansion of euro interest-swap activity and the rise of pan-European equity based index trading. The euro has also led to the creation of a more homogenous *euro-denominated government bond market*, with largely convergent prices among euro-area Member States (Graph 2.12) and evidence of cross-border portfolio diversification. However, this market remains fragmented on the supply side, which results in inefficiencies restricting its full development. The integration of *equity markets* has also thus far been less successful. The euro has affected the behavior of investors, with an overall reduction in “home bias” and a re-orientation of asset managers’ investment strategies towards a European approach. However, there are still few cross-border listings. Also *cross-border banking* has increased but it remains limited, in particular for retail activities which remain locally oriented. Due to remaining barriers, mergers and acquisitions in the banking sector have mainly

<sup>14</sup> Credit institutions and money-market funds.

<sup>15</sup> Indicators of financial integration in the euro area – ECB (September 2006).

## Annual Report on the Euro Area

occurred along national lines and national retail interest rates remain dispersed (for example for consumer credits or mortgages). Finally, consolidation has also taken place in *market infrastructure*. Progress has been made in the integration of national payment systems, such as through the Eurosystem's TARGET and consolidation in clearing and settlement systems. Many stock exchanges have also merged and further consolidation could take place.

Graph 2.12: Standard deviation of euro-area government bond yield spreads (in %)

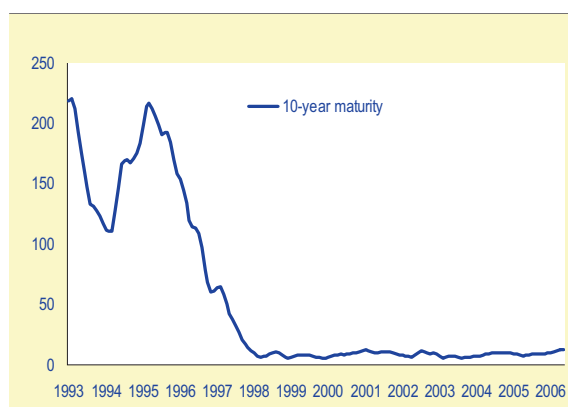

Note: Spreads were calculated against the German benchmark.  
Source: ECB.

88. **Remaining sources of fragmentation create bottlenecks for the euro area.** The euro has acted as a catalyst for financial integration, but more integration is needed to create an efficient financial system, boost economic growth and improve the euro area's capability to deal with economic shocks. As the introduction of the euro has removed one important obstacle to financial integration and increased the incentive to engage in cross-border financial transactions, the urgency of removing remaining obstacles has been brought to light. The specific importance of financial integration to the smooth functioning of EMU gives the euro area a good reason to be in the vanguard of the integration process and take a leading position vis-à-vis the remainder of the EU. For instance, a study on the costs and benefits of integration of EU mortgage markets estimated that full integration of mortgage markets would increase GDP in the euro area by 0.7% and private consumption by 0.5% in 2015. Gains would mostly derive from increases in product availability, which would in turn boost total demand for housing and domestic investment. The Commission White Paper on Financial

Services Policy in 2005-2010 has set the agenda for EU-level financial sector reform in the coming years. High priority is given to timely and convergent implementation and rigorous enforcement of EU law at Member State level. Another priority is to ensure continuous consultations and impact assessments of new Commission proposals as well as ex-post evaluation of existing EU policies and rules implemented under the FSAP. The Single Euro Payments Area (SEPA) is another promising project to advance euro-area integration. SEPA will enable consumers, companies and other economic actors to make and receive payments in euro, whether across or within national boundaries under the same basic conditions, rights and obligations, regardless of their location.

### 2.5 PRODUCT MARKET REFORMS REMAIN NECESSARY

*Competition problems and rigid prices remain, especially in network industries and services*

89. **Flexible and competitive product markets are essential for a well-functioning euro area.** A country with competitive markets and flexible prices adjusts more easily to shocks in competitiveness. Moreover, higher market flexibility facilitates the adoption of new technologies and enhances productivity growth. In order to compete successfully in the global marketplace, euro-area firms need to have a sound and competitive home base, which provides incentives for firms to improve efficiency and innovative performance. The internal market provides the opportunity to become increasingly specialised in high-value added production and exploit economies of scale in R&D, production and advertising.

90. **EMU has deepened economic integration between euro-area Member States.** Better allocation of resources resulting from more open markets can positively affect productivity growth within the euro area. Economic integration can lead to increased sectoral and regional specialisation, as in an integrated market the emergence of front-runners on specific location or advantages is expected. Research reveals that the single currency has increased intra euro-area trade by



5% to 10% and may deliver further benefits over a longer period of time. Furthermore, EMU has provided incentives for mergers and acquisitions (M&A) within the euro area: the share of the euro area in the total cross-border M&A by euro-area firms increased from 34% in 1999 to 42% in 2004, despite sluggish economic growth in the interim. Cross-border M&A are especially important to boost market integration in deregulated network industries as they give firms the possibility to expand beyond their traditional domestic markets by acquiring or merging with local firms. EMU has also led to substantial price convergence (Table 2.2): the level of price dispersion for traded goods in 2001 was already close to that of the US, while the level of price dispersion for non-tradeables was lower than in the US.

**Table 2.2: Price dispersion in the euro area**

	1999	2001	2003	2005
Services	18.3	17.6	15.4	14.2
Durable Goods	8.8	7.3	6.7	6.5
Semi-Durable Goods	8.8	7.6	5.7	6.0
Non-durable Goods	9.6	11.9	12.0	10.9

Note: Price dispersion is measured through the coefficient of variation of prices contained in the HICP.

Source: Commission services.

91. *Yet, there is scope for further progress regarding intra euro-area trade.* With respect to the rest of the world, the trade openness of the euro area is similar to that of the US. The extra-euro area trade to GDP ratio in manufacturing is also similar to the figure for the US. However, the intra-euro area trade to GDP ratio in manufacturing (around 20%) was below that of intra-US trade in manufacturing (30%) in 2002. Intra euro-area trade in services remains particularly low, representing just slightly more than 5% of GDP compared with over 30% of GDP for trade in goods.

92. *Prices remain rigid in the euro area, especially in services.* Recent surveys on price setting behaviour, published in 2005, point to a lack of flexibility in product markets. On average, only 15% of consumer prices and 20% of producer prices change every month in the euro area. In the US the frequency of change in producer prices is similar, but consumer prices are considerably more flexible, with 26% of prices changing every month. Overall, consumer prices change on average every two quarters in the US against four to five quarters in the euro area. Prices of services are especially sticky. Downward price rigidities are strongest in network industries, retail trade and professional services, where regulation is more stringent. The most prominent factors preventing immediate price adjustments in the euro-area are implicit and explicit contracts with customers (that firms use to seek to make sales more profitable) and the still widespread use of "cost-based pricing" strategies that imply that prices are not changed unless costs change, and "competitors' prices" strategies when firms prefer not to change their price unless one of their competitors moves first.

93. *The adoption of the Directive on Services in 2006 represents notable progress.* It sets up a dynamic process for modernising national systems regulating service activities, lifting barriers and improving administrative co-operation between Member States. In particular, the Directive introduces an ambitious programme of administrative simplification under which Member States will have to screen their legislation relating to services, simplify requirements as well as administrative procedures and formalities. The setting-up of "points of single contact" and electronic procedures will make it possible for service providers to complete all procedures and formalities relating to their activities through one single interlocutor and by electronic means. The Directive will also substantially facilitate the establishment of business (by obliging Member States to eliminate unjustified requirements) and the provision of services across borders (by limiting the grounds and circumstances upon which Member States can impose their legislation to services legitimately provided from other Member States). Moreover, an Internal Market Information System (IMI) will improve administrative co-operation between Member States' competent authorities by providing for a

## Annual Report on the Euro Area

tool for fast and secure information exchange and cooperation. Countries in the euro area should concentrate efforts and deploy the necessary resources to ensure a proper and consistent implementation as part of their efforts to enhance competition and reduce administrative burdens on businesses.

94. **Competition issues in network industries require greater effort.** Many Member States are currently addressing competition issues in network industries, but a greater effort is needed with respect to issues such as the effective separation of network and generation activities (unbundling) as well as the budgetary resources and statutory independence of regulatory bodies. In particular, unbundling aims to increase price competition in the energy consumer market, to remove access barriers to energy networks and avoid distortions in network investments. Even when all legal barriers to trade are removed, market access remains hampered by insufficient cross-border interconnecting infrastructures. Competition problems persist in specific sectors. For example, in the electricity and gas sectors, incumbent firms still hold high market shares.

95. **Energy and climate policy has made its way to the top of EU's political agenda.** Soaring energy prices, rising concerns about climate change and its potentially devastating effects on wealth accumulation as well as concerns about the security of energy supply, have put energy and climate policy high on the political agenda. As a result, the EU put forward a series of policy initiatives in the energy field to address in a balanced way the three objectives of security of supply, competitiveness and environmental sustainability. Competitiveness, energy and environmental policies are closely interrelated and have a significant impact in particular on many basic and intermediate product industries. Thus, a cost-effective tackling now of the upcoming issues regarding climate change and security of supply will help to safeguard the competitiveness of the EU's economy in future (see Box 5 for an elaborated analysis). While this new energy policy is very important for all EU Member States, it also raises some specific issues for euro area members in view of its possible implications on, *inter alia*, current-account developments, price adjustment and adaptability of product markets.

### ***Entrepreneurship and innovation need to be fostered***

96. **Business dynamism could be further improved.** Historical data show that while product market regulation in the euro area countries declined during the 1998-2003 period, entry and exit rates remained substantially below those of the US (Table 2.3). For example, the average entry rate over the 1997-2003 period was larger in the US than in all major euro-area countries. The gap with respect to the US was even wider in terms of exit rates, reflecting the social stigma associated with going bankrupt as well as the more onerous bankruptcy legislation in Europe. Not only entry and exit *per se* but also the growth performance of enterprises in the years after entry is critical. According to an OECD study, US firms are smaller than euro-area firms when they enter the market. If they survive, they grow much faster and reach higher average sizes in terms of employment. Recent measures have been taken or announced to promote better regulation and facilitate business start-ups. Nevertheless, further improvements to the business environment (e.g. access to financing, restrictive employment protection legislation) would allow the best performing firms in the euro area to grow rapidly.

**Table 2.3: Entry and exit of companies in selected countries**

	Entry rate	Exit rate
Germany	4.2	3.0
France	4.5	2.0
Italy	3.5	3.0
Spain	8.3	2.0
Netherlands	6.2	1.2
US	10.0	9.7

Note: 1997-2003 data for EU countries, 1999-2001 for the US  
**Source:** Commission services.

97. **Barriers to entrepreneurship in the euro area decreased less.** The World Bank's "ease of doing business" indicator shows that in 2006 it is still more difficult to start a new business in most euro-area countries than in the United States. This is confirmed by the OECD's indicator, which shows that barriers to entrepreneurship have declined by less over the 1998-2003 period than barriers to trade, investment and state control, and that most euro area Member States underperformed relative to the US. Hence, more could be done to improve the regulatory environment, especially for small and medium enterprises.



### Box 5: Energy policy and the euro area

A broad policy consensus has emerged that the EU should continue on a path towards significantly reducing greenhouse gas (GHG) emissions beyond 2012 and dramatically improving on the economy's energy efficiency. At the same time, the EU must diversify the energy mix much more in favour of renewable and carbon-free energies.

To this end, the Commission adopted in January 2007 a comprehensive "Energy Policy for Europe" which intends to reconcile environmental aspects, security of supply and ensure the competitiveness of Europe. These objectives and a comprehensive Energy Action Plan with highly ambitious goals were endorsed by the European Council at its Spring Meeting. Main targets of the Energy Action Plan are to improve the energy efficiency by 20% in 2020 compared to the baseline as well as to increase the share of renewable energies in overall EU energy consumption to 20% by 2020, with a separate 10% target for biofuels. Regarding climate policy, the European Council stipulated a firm independent commitment for the EU to reduce its greenhouse gas emissions by 20% in 2020 compared to 1990. An even more ambitious 30% reduction target was announced provided that commitments to comparably ambitious reduction targets are made in an international agreement.

Implementing these ambitious legislative proposals will imply a tremendous regime change as regards the European energy systems as well as energy production and consumption in Europe. Indeed, the twin objectives of reducing GHG emissions and reducing energy consumption will require a substantial cut in the use of carbon-intensive energy sources and an improved energy performance of goods and services marketed in the EU. Also, diversifying energy supplies and strengthening transmission grids to improve energy security and complete the internal market, will require substantial investments and improvements in energy production as well as its distribution.

Currently the Commission works towards proposals on how to best achieve these targets and on the burden sharing between individual Member States. The below table shows that even between euro-area countries there exist substantial differences as regards key performance indicators of energy and climate policies. On the one hand, these differences indicate that there exists ample room for improvement without really challenging the economic status quo if all countries aimed at benchmarking the best performers. On the other hand, they show that there is still a long distance to go to achieve the overall energy and climate policy objectives.

**Table: key performance indicators of energy and climate policies.**

2004	EU target	EA <sup>(3)</sup>	BE	DE	IE	EL	ES	FR	IT	LU	NL	AT	PT	SI	FI
<b>Energy intensity</b> kgoe per € 1000 (1)	-20% to 40%	185	208	159	157	240	223	185	189	194	203	<b>146</b>	240	329	272
<b>GHG emission</b> Tons of CO <sub>2</sub> equivalent per capita	n/a	11	14	12	16	12	10	9	10	28	13	11	<b>8</b>	10	15
<b>Distance to Kyoto target</b> % (2008-2012) (2)	92% of 1990	n/a	-8	-4	-10	<b>+1</b>	-33	+1	-19	-28	-8	-29	-14	-7	-15
<b>Renewables</b> Share of gross inland consumption (%)	20%	6.3	2.1	4.0	2.1	5.1	6.4	6.3	6.8	<i>1.6</i>	2.9	20.7	14.9	11.6	<b>23.4</b>
<b>Biofuels</b> Share of fuel consumption for road transport (%)	10%	0.9	<i>0.0</i>	<b>1.8</b>	n/a	n/a	0.8	0.8	0.7	<i>0.0</i>	n/a	0.2	n/a	n/a	0.2
<b>CO<sub>2</sub> emissions of passenger cars</b> g/km	120	161	156	175	168	169	155	153	150	170	171	162	<b>147</b>	n/a	<i>180</i>
<b>Interconnection capacity of national electricity grid</b> Share of generating capacity (%)	10%	n/a	<b>30.1</b>	15.1	5.2	10.9	<i>4.9</i>	8.4	6.6	n/a	28.1	<b>30.1</b>	8.5	n/a	21.1

Best performance is given in bold; worst performance in italics.

(1) At 1995 prices. (2) Positive value means overachievement. (3) Euro area 13.

**Source:** Commission services.

At first glance one would expect that energy production as well as energy-intensive goods and services will become significantly more expensive over the coming decade. Investments in improving energy efficiency and tightening of energy performance standards are likely to make these products more expensive. This might give rise to accelerating headline inflation. On the other hand, energy efficiency measures will result in savings on the energy bill and induce cost-saving technical progress. Additionally, if intended measures induce more competition in energy networks, this exerts downward pressure on energy prices. These factors partially compensate the afore-mentioned tendency of rising energy prices. Moreover, the impact of these policies on individual regions of the euro area might be rather different, depending on how new standards and instruments will be designed across Member States.

All this asks for a careful design of instruments to achieve the overall energy and climate objectives. Thus, special attention should be given to cost-effective instruments that strengthen market powers and competition and, thus, enable a largely inflation- and friction-free pro-active climate and energy policy.



Graph 2.13: Euro-area Product Market Regulation indicators  
(1998 levels and contribution to 1998-2003 change)

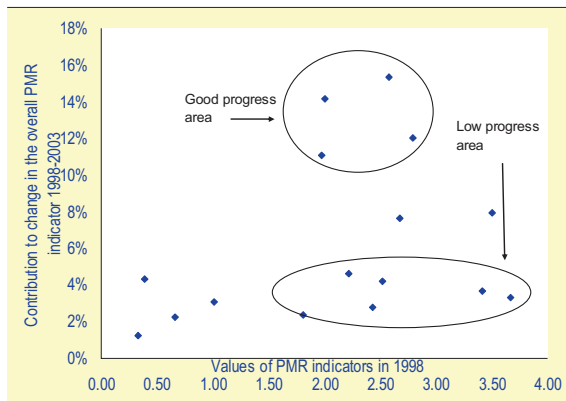

Note: Good progress area includes indicators such as price controls, State control over business enterprises, tariffs and ownership barriers. Low progress area includes scope and size of public enterprise sector and administrative burden to companies.  
**Source:** OECD.

98. *The innovative performance of the euro area lags behind that of top performers.* The innovative performance of the euro area, measured either by Research and Development (R&D) spending as a percentage of GDP or by the summary innovation index, is lower than in the US and Japan (Graph 2.14). Since the launch of the Lisbon Strategy for Growth and Jobs in 2000, all of the euro-area Member States undertook significant efforts to boost R&D and innovation, develop human capital and ensure a more innovation-friendly business environment. Nevertheless, total R&D spending of the public and private sector in the euro area has been stagnating at around 2% of GDP, which is well short of the Barcelona objective of reaching 3% of GDP by 2010. It continues to be below the levels in the US (2.6%) and Japan (3.2%). Furthermore, business expenditure on R&D in the euro area, at slightly above 1.2% of GDP, is significantly lower than in the US (1.9%) and Japan (2.4%). The National Reform Programmes (see section 2.3) have announced promising reforms to encourage R&D and innovation.

99. *Improving the innovation environment remains an important challenge in euro-area Member States.* Despite increased efforts to ensure conditions favourable to innovation, more ambitious action is needed. Companies in the euro area are not sufficiently encouraged to innovate: some markets, in particular in services, remain too fragmented; the Intellectual Property

Rights (IPR) could be clearer and more efficient and the potential of a less constrained public procurement system has not been sufficiently exploited. Currently in the euro area only 17.5% of public procurement is published and thus open to competition. National systems of higher education exhibit a number of structural weaknesses. Moreover, the pool of researchers in the euro area, in particular in the business sector, is considerably smaller than in the US or in Japan.

Graph 2.14: Research and Development and innovation performance

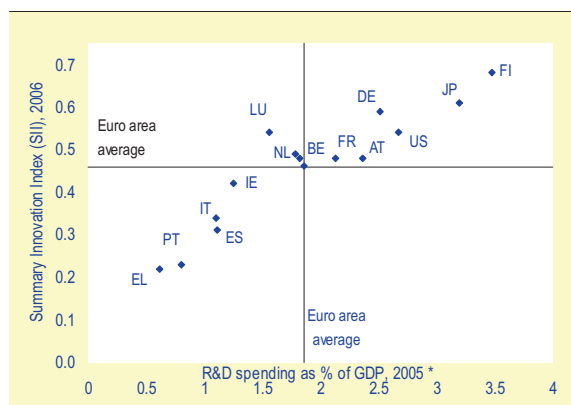

(\*) 2004 data for IT, NL and US; 2003 data for JP.  
**Source:** Commission services.

Graph 2.15: Launching of new goods and services in national and EU markets (\*)

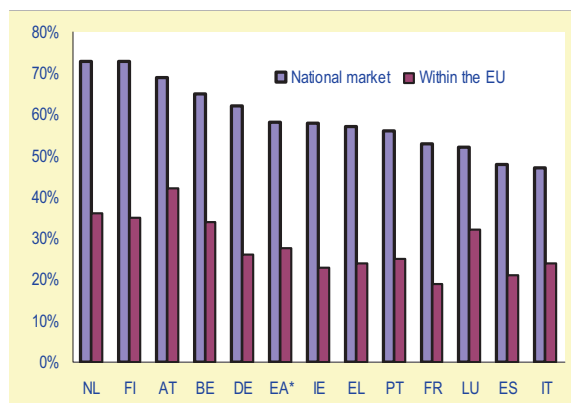

(\*) Percentage of companies having declared the launching of new goods and services in the two years preceding the poll.  
**Source:** Commission services (Innobarometer 2004).

100. *Euro area companies do not yet fully exploit the opportunities provided by the Internal Market.* Evidence shows that over 50% of innovative companies are launching their new products on national markets, while less





than 30% are doing the same in other Member States (see Graph 2.15). Other means of knowledge diffusion, such as patent disclosure and licensing, are therefore essential to stimulate technological progress and productivity growth. Intellectual property rights can play indeed an important role in fostering innovation but the design of an effective system remains a difficult challenge. On the one hand, granting protection must not stifle diffusion of innovation. On the other hand, SMEs, especially start-ups, have specific needs for patents, as their business is generally focused on one activity and the protection of a competitive advantage based on technology may be crucial for their survival.

101. *The forthcoming Internal Market Review should highlight main achievements and unexploited potential.* Following the conclusions of the European Council of June 2006, the Commission is carrying out an assessment of the internal market policies in view of the upcoming challenges in terms of new technologies, globalisation and EU enlargement. Internal market policies have to take into account the fact that the euro will progressively become the currency of a large majority of EU Member States. In an interim paper released in February, the Commission pointed out that policies and instruments should become more flexible and concentrate on actions they have most impact. An increased partnership between Commission and Member States would also be helpful to improve the governance of the Single Market. A full review transposing these principles into concrete proposals is scheduled for publication in the autumn of 2007.

## 2.6 WAGE DEVELOPMENTS AND COMPETITIVENESS

102. *Wages in the euro area have continued to grow moderately.* In spite of a sharp rise in oil prices, HICP inflation above 2% as well as strong output and employment growth in 2006, wage growth was contained. The compensation per employee increased by 1.8% (year-on-year) in the fourth quarter of 2006. This figure is close to the figures recorded since the introduction of the euro. There were some signs of increasing wage growth in the first half of 2006 (Graph 2.16). However, in the second half of the year, some indicators fell to levels that prevailed

for most of the period since 2004. Also from a historical perspective, the wage developments registered in the past few years have been both smoother and significantly more moderate than in previous cycles. This has contributed to a more accommodative monetary policy during the latest downturn.

Graph 2.16: Wage indicators in the euro area (year-on-year growth)

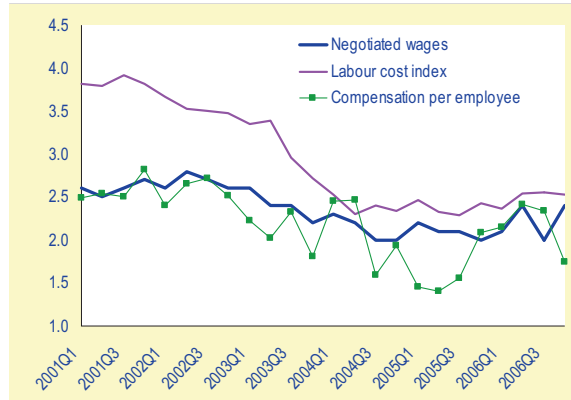

Source: Commission services.

103. *Wage behaviour in Germany has been crucial for the euro area.* The rather muted wage growth in the euro area has been heavily influenced by low wage growth in Germany. Since the start of EMU, compensation per employee in the euro area grew by 2.5% annually. However, excluding Germany from the aggregate would yield a less-benign figure of 3% (Graph 2.17).

Graph 2.17: Unit labour costs in the euro area

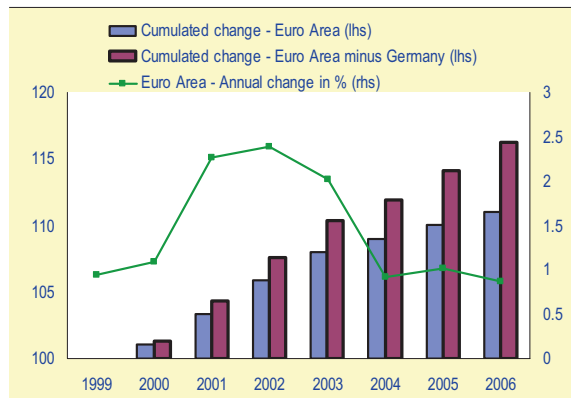

Note: Cumulated figures are expressed in index (1999=100)

Source: Commission services.

104. *The different behaviour of wages compared to past recoveries and high oil*

## Annual Report on the Euro Area

**price episodes point to structural changes.** In particular, there have been significant changes in wage formation in the euro-area economies since the 1990s. Automatic wage indexation has become less prevalent. Labour market reforms that have increased flexibility have probably also contributed to dampen wage growth. Altogether, this has reduced the potential for second-round effects induced by the previous oil price increases. Global trends seem to have played a role. A heightened globalisation process has intensified the degree of competition in product markets and has dampened the demand for higher wages. The direct impact of the oil price increase on inflation has also been mitigated by the substantial reduction in the oil intensity of production and the strength of the euro exchange rate. Similarly, the share of household spending on fuel has also declined steadily over the past twenty years. This means that oil price increases are less likely to have an as strong direct impact at the production stage and on wage demand as they had in the 1970s or 1980s.

Table 2.4: **The elasticity of wages with respect to expected inflation**

	Short-term		Long-term	
BE	0.62	(4.22)	0.86	(3.44)
DE	1.00	(4.76)	0.78	(1.96)
EL	1.18	(5.3)	0.92	(1.98)
ES	1.13	(8.36)	1.00	(5.76)
FR	1.08	(8.75)	0.83	(2.44)
IE	1.19	(12.8)	0.93	(4.42)
IT	1.44	(18.7)	0.99	(3.13)
NL	1.67	(8.52)	0.81	(2.81)
AT	1.72	(9.26)	0.92	(1.77)
PT	0.67	(9.33)	0.97	(7.96)
FI	1.3	(10.1)	1.02	(4.14)
US	0.75	(12.2)	0.83	(6.20)

**Note:** Elasticities from an error correction model with instruments. The dependent variable was compensation per employee 1972-2004. Control variables were labour productivity, unemployment, terms-of-trade, t-values in brackets.

**Source:** J. C. Duque, R. Ramos and J. Suriñach (2006): "Wages and productivity: the role of labour market institutions in OECD countries" *Empirica*.

105. **The credibility of the ECB is another key reason for the moderate wage developments.** Wage claims could be influenced by both past and expected inflation. If expected inflation increases, employees could demand higher wages. As can be seen in Table 2.4, the adjustment of wages to expected inflation takes some time to materialise, but over time the response seem to be close to unity in

most euro-area countries.<sup>16</sup> Anchoring inflation expectations is thus crucial and all measures point that the ECB has been very successful in keeping them stable at a level consistent with price stability. Especially the longer term and the expectation for two years ahead have been very stable. The expectation for one year ahead has showed a slightly higher volatility and increased during most of 2006 but has stabilised at 2.1%, i.e. close to the target of the ECB.

106. **The outlook for wages is surrounded with uncertainty.** In 2007 several wages agreements will be renegotiated. The brightening economic situation, the steady decrease in unemployment and the emergence of labour shortages in some countries could exert upward pressure on wage settlements. In addition, as the phase of wage adjustment following the German unification is coming to an end, higher wage settlements in Germany could raise wage demands in other euro-area countries. Finally, companies might feel that they can pass-through a wage cost increase on to consumers due to the stronger domestic demand. For smooth adjustment it is essential that the process of wage determination in euro-area members pays due regard to price stability, medium-term trends in productivity and differences across skills and local labour-market conditions

Graph 2.18: **Real effective exchange rate developments**  
(Index 1999=100)

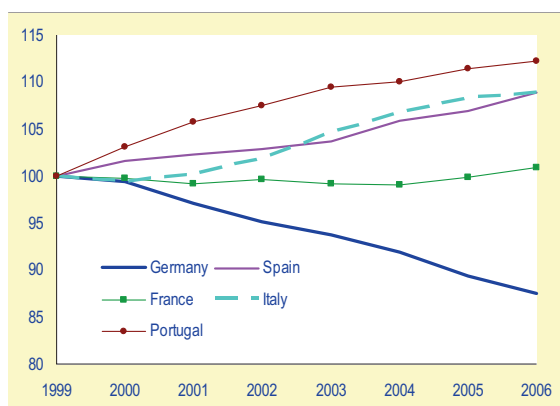

**Note:** The real effective exchange rate is based on the unit labour costs. An increase is equivalent to a deterioration of costs competitiveness.

**Source:** Commission services.

107. **Wage developments at the country level play an important role in the adjustment to**

<sup>16</sup> From a theoretical perspective, the causal link is unclear between wages and prices, as the causation runs both ways and is blurred by a complex dynamics.



**competitiveness shocks.** A country's competitiveness (i.e. expressed in unit labour costs relative to the average of main trading partners) needs to adjust when its economic conditions move out of line with those in the rest of the euro area. With slow wage responses, there is a risk that movements in the intra euro-area real effective exchange rates become persistent in the medium-term with lasting losses in output and employment or persistent overheating of the economy as a result (see sections 2.1 and 2.2). Cross-country differences in wages and productivity growth resulted in substantial changes in price and cost competitiveness in recent years (Table 2.5 and Graph 2.18).

**Table 2.5: Growth in real wages (RW) and labour productivity (LP) across cycles**  
(annual change in %)

		Previous two cycles	Current cycle	Diff.
Euro area	RW	0.4	-0.4	-0.8
	LP	1.6	1.1	-0.5
DE	RW	0.9	-1.2	-2.1
	LP	2.1	1.8	-0.3
FR	RW	1.0	1.2	0.2
	LP	1.3	1.2	-0.1
IT	RW	-0.5	-0.6	-0.1
	LP	1.4	0.3	-1.1
ES	RW	-0.6	-0.8	-0.2
	LP	1.6	0.1	-1.5
NL	RW	0.6	0.3	-0.3
	LP	0.4	2.5	2.1

Source: Commission services.

**108. Smooth adjustment requires unit labour costs and wages to respond to fluctuations in output gaps.** Evidence presented in a recent Commission study<sup>17</sup> suggests that the responsiveness of unit labour costs and wages to the slack in the economy varies considerably across countries. For example, a one percentage point change in the output gap of Italy and Austria leads to a 1.2 percentage point change in the growth rate of unit labour costs (ULCs). The response of the unit labour costs growth is among the lowest in Ireland (0.7%), France

<sup>17</sup> European Commission (2006), "Market adjustment, the competitive channel", Chapter 4 in "Dynamic Adjustment in the Euro area: Experiences and challenges", EU Economy Review 2006.

(0.6%) and Portugal (0.4%). However, there are less cross-country differences in manufacturing than in the rest of the economy. The elasticity of unit labour costs also tends to be stronger. This points to a quicker adjustment in industry to withstand area-wide and global competitive pressures (see Graph 2.19).

**Graph 2.19: Relative unit labour cost elasticity to output gap in the manufacturing sector**

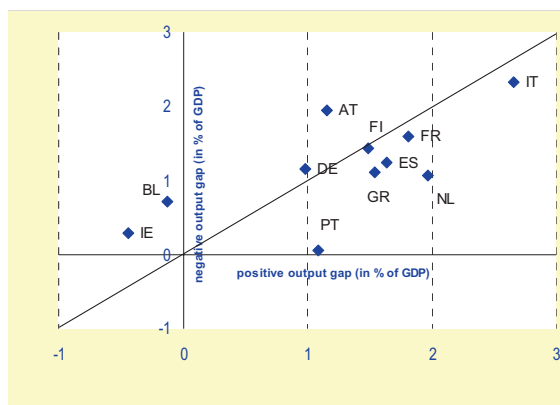

Note: BL=Belgium and Luxembourg. The graph depicts the elasticity of unit labour costs to the previous year's output gap over the period 1970-2000. Two sets of results are estimated depending whether the output gap is positive or negative. The graph shows for each country two ULC elasticities, one when the output gap is positive and one when it is negative.

Source: Commission services.

Significant cross-country differences could also be found in wage elasticities, with Germany recording a higher sensitivity to economic conditions than other euro-area countries. In addition, the response of wage costs is asymmetrical over the cycle: in some countries (see Graph 2.20), wage growth tends to pick up more quickly in upturns than it tends to slow in downturns. This is especially the case for Italy, the Netherlands, Portugal, Belgium-Luxembourg and Greece. Downward wage and ULC rigidity implies that unemployment has to rise more strongly to trigger a change in competitiveness.

**109. Countries with downward rigidities are confronted with specific challenges.** If there are downward rigidities, it is difficult for countries to rebalance their cost competitiveness by keeping unit labour costs below the euro-area average for some time, especially when growth is low. This could delay adjustment a great deal and lead to significant output and employment losses. Incidentally, countries with stronger rigidities tend to have witnessed higher relative growth of unit labour costs between 1999 and

## Annual Report on the Euro Area

2005. Finally, other hindrances could arise for countries with lower wage levels compared to the euro-area average, since there is a long-term tendency for nominal prices and wages to converge in the euro area. Such pressures arising from nominal convergence might make adjustment more difficult.

Graph 2.20: **Relative wage elasticity to output gap in the total economy**

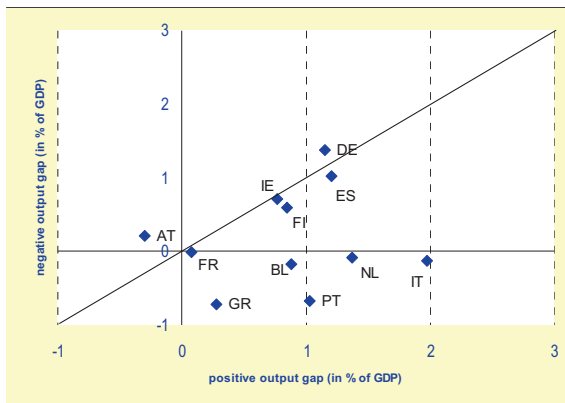

Note: BL=Belgium and Luxembourg. The graph depicts the elasticity of wages to the previous year's output gap over the period 1970-2000. Two sets of results are estimated depending whether the output gap is positive or negative. The graph shows for each country two wage elasticities, one when the output gap is positive and one when it is negative.

Source: Commission services.

## 2.7 CONCLUSIONS

110. **Economic adjustment within the euro area remains sluggish.** Growth and inflation differences within the euro area are not unusually high, but their persistence shows that the adjustment process in the euro area is not functioning smoothly. The fact that some current account differences in the euro area have become entrenched over time, also suggests that changes in countries' competitiveness have been too sluggish. Finally, adjustment in euro-area countries has been hampered by the relatively low productivity growth in the euro area.

111. **Country-specific experiences provide useful lessons.** First, the competitiveness channel plays an important role but has not always worked well in practice due to sluggish wages and prices. Second, the real interest rate channel can complicate adjustment dynamics in the short and medium term as real interest rates tend to fall during economic booms (and rise during downturns.) Third, fiscal policy has been pro-cyclical in some countries which have failed to accelerate fiscal consolidation in "good times"

and have consequently ended up with insufficient fiscal flexibility to support economic activity during the downswing. Fourth, financial markets have played an increasing role, though its effect on adjustment has not always been beneficial in practice due to, for instance, asset price volatility. Finally, it is the interaction of these different elements that shapes a country's adjustment process. It is important that policy-makers ensure that this interaction does not lead to unduly large swings in output and employment.

112. **Euro-area Member States have striven to stimulate growth and employment but more attention is needed for policies that raise their adjustment capacity.** The Commission's Annual Progress Report notes that Member States have undertaken positive steps to foster growth and employment. However, the euro-fiche in the Annual Progress Report also reported that Member States are doing little in the way of reforms that could raise the euro-area's adjustment capacity and that are therefore important for the smooth functioning of EMU.

113. **Further financial market integration, product market reforms and sensible wage setting would smooth the adjustment process.** Financial market integration is still far from complete, especially in certain retail segments. This means that the potential of financial markets to cushion economic shocks and encourage risk-sharing is not yet being exploited to the full. Further product market reforms remain necessary to raise price flexibility and boost productivity growth. There is currently still much evidence of competition problems and rigid prices, especially in network industries and services. Moreover, there are indications that business dynamism in the euro area is insufficient and that entrepreneurship and innovation need to be fostered. Finally, wage developments at the country level play an important role in adjustment to competitiveness shocks. On the whole, national wage developments should be consistent with overall price stability in the euro area and cross-country differences in productivity growth. Member States that need to regain competitiveness should keep their unit labour cost growth below the euro-area average until economic imbalances are corrected.



### 3. THE EXTERNAL DIMENSION

114. **EMU has a global impact.** EMU is often considered the most important event in the international monetary system since the collapse of the Bretton Woods exchange rate system in the early 1970s. Section 3.1 discusses recent exchange rate developments and developments in relation to global current account imbalances. Section 3.2 continues with a presentation of recent data on the euro as a global currency. A discussion of the rapid economic development in China, India and Russia and their increasing economic integration with the euro area follows in section 3.3. Section 3.4 presents the current state of play on the external representation of the euro area and the IMF discussion on quota and voice. Section 3.5 concludes.

#### 3.1 THE EURO'S EXCHANGE RATE AND GLOBAL IMBALANCES

115. **The euro gained substantially in value vis-à-vis both the US dollar and the yen.** Since January 2006, the euro appreciated by 14.6% against the US dollar in three rounds of appreciations in the spring and autumn of 2006 and in the spring of 2007 (see Graph 3.1). Against the yen, the euro appreciated at a steady pace in the course of 2006. A correction in February 2007 was short-lived, and the yen quickly resumed its depreciating trend. In mid-April 2007, it stood at 162 JPY, 15.9% higher than a year earlier and the lowest yen exchange rate since the introduction of the euro.

116. **The euro's evolution against the currencies of other main trading partners was more mixed.** Since the beginning of 2006, the euro depreciated slightly by 1.5% to 0.68 GBP by mid-April. The euro also depreciated by 1.9% against the Swedish krona. While its appreciation against the Swiss franc was moderate (5.5%), the appreciation against the Chinese renminbi was more pronounced (9.7%).

Graph 3.1: Changes in EUR bilateral rates  
(in % - daily data, January 2006–Mid-April 2007)

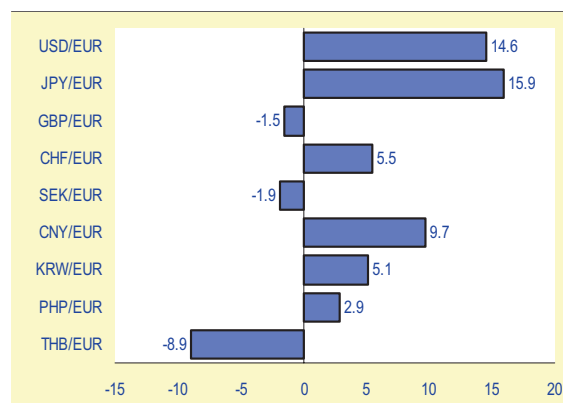

Note: "-" indicates a euro depreciation.  
CHF=Swiss Franc; SEK=Swedish Crown;  
CNY=Chinese Renminbi; KRW=Korean Won;  
PHP=Philippine Peso; THB=Thai Baht.  
Source: European Central Bank.

117. **The euro's appreciation against the US dollar and the yen was driven by an improvement of euro-area economic fundamentals.** The euro-area economy grew by 2.7% in 2006, the highest annual growth rate since 2000. The US economy grew at a rate of 3.3%, but growth decelerated in the course of the year as industrial production was slowing down. In Japan, economic growth remained robust, though some of the optimism of 2005 did not materialise and it took longer than expected to leave deflation behind. Structural improvements in the euro-area economy also contributed to the strengthening of the euro. The annual potential growth rate in the euro area has accelerated to somewhat above 2%.

118. **The euro's real effective exchange rate rose less than bilateral changes against the US dollar and yen suggest.** Ultimately, what matters for the competitiveness of euro-area exports is the real effective exchange rate (REER). Graph 3.2 presents the REER as a trade-weighted average exchange rate against a group of 41 countries, accounting to more than 80% of extra euro-area exports, adjusted for

## Annual Report on the Euro Area

differences in consumer price inflation (CPI). In 2006 the euro REER appreciated 3.5% and now stands 3.3% above its long-term (1994-2006) average.

Graph 3.2: Euro real effective exchange rate\*  
(Monthly data, January 1994 – March 2007, 1999=100)



\*Against group of 41 countries representing more than 80% of extra euro-area exports.

Source: Commission Services.

119. *The euro's appreciation was also a sign of global interest rate differentials.* In turn, interest rate differentials also reflected the euro-area's cyclical performance. Between December 2005 and April 2007, as shown in Graph 3.3, the ECB increased its main policy rate in seven steps, of 25 basis points (bp) each, to 3.75% (see Chapter 1). The US Federal Reserve raised its interest rate by 4.25% in total until 5.25% between June 2004 and June 2006. As the prospect of further rate hikes in the US waned and expectations of rate cuts in 2007 began to take hold, the differential in expected short-term interest rates diminished by some 90 bp in the second half of 2006. The yield differentials of the benchmark 10-year bonds also decreased from a 100 bp gap last spring and summer to around 50 bp by April this year. The negative interest rate gap between Japan and the euro area widened, as the Bank of Japan pursued a cautious course. In light of continued weak price developments and a slow recovery in domestic consumption, the Bank of Japan increased its interest rate in July 2006 and February 2007 to reach 0.75%. Despite sound growth perspectives in Japan, expectations of a persisting interest gap have given rise to very substantial carry trades<sup>18</sup>, which weakened the

<sup>18</sup> Carry trades consist of borrowing in a country with low interest rates (e.g. Japan) in order to invest in a country with high interest rates (e.g. Australia or New Zealand).

yen further against the currencies of countries with higher interest rates. Carry trades, which expose its actors to exchange-rate risk, were also helped by the relatively low level of volatility in foreign exchange markets.

Graph 3.3: Central bank policy rates  
(Daily data, January 1999 – April 2007)

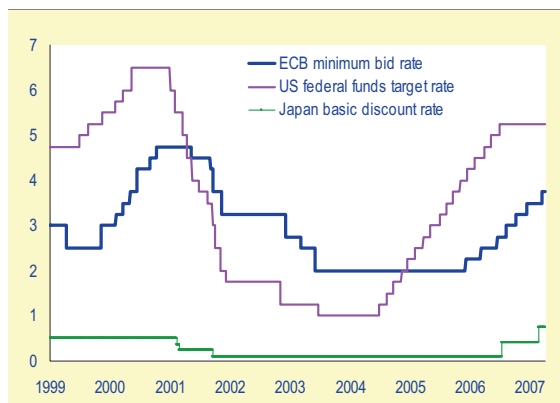

Source: EcoWin.

120. *The impact of a stronger euro on economic growth is likely to be moderate at the current juncture.* In the past, euro-area economies were able to cope with an appreciating currency whenever their domestic demand was robust, as is now the case. Moreover, the euro-area's export sector is healthy and its profit margins have increased substantially in the past three years. Finally, the negative impact of an appreciation on output growth via the export sector is partly compensated by lower import prices and higher real incomes.

121. *Global current account positions seem to have had only a minor impact on exchange rates.* Exchange rate developments in 2006 were only partly in line with what one would expect in light of the structure of global current account positions. While the US dollar depreciated substantially against the euro and the pound sterling, its depreciation vis-à-vis surplus countries was more muted. In real effective terms, the US dollar thus depreciated 1½ % since early 2006. The Chinese renminbi appreciated somewhat vis-à-vis the US dollar but remained broadly stable in real effective terms, even though China's trade surplus has been surging. Despite Japan's current account surplus, the yen real effective exchange rate fell by some 8% in 2006 and continued to depreciate in early



2007 to levels last seen in the first half of the 1980s.

122. **The current account shows some signs of stabilising in the US.** For the year 2006 as a whole, the US current account deficit widened to USD 857 billion, or 6.3% of GDP after 6.2% in 2005 (see Graph 3.4). However, on the back of lower oil prices, dollar depreciation and the global rebalancing of growth, the deficit shrunk somewhat in the fourth quarter, to 5.8% of GDP.

Graph 3.4: Evolution of current account balances  
(Billions of USD – annual data)

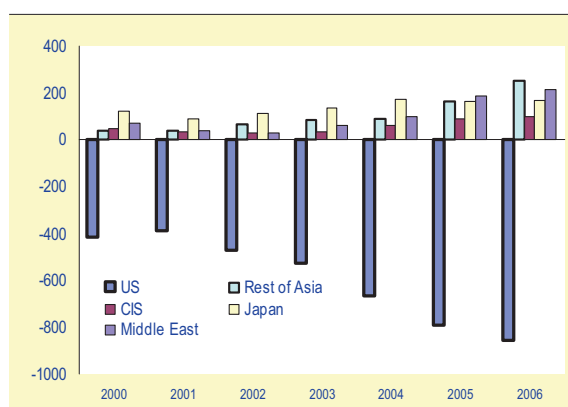

Source: IMF World Economic Outlook, April 2007.

123. **Imbalances also increased in the major surplus regions.** In Japan, emerging Asia and oil-exporting economies in the CIS and in the Middle East, imbalances continued to widen. China's global current account surplus increased sharply in 2006 – by almost 50% compared to the previous year – to a record USD 238.5 billion, thereby significantly exceeding the previous year's record of 9.1% of GDP. Equally, Russia's current account surplus increased to USD 95.6 billion in 2006 from USD 83.3 billion in the previous year, which is around 9.8% of GDP. Oil-exporting economies in the Middle East received significantly higher revenue due to the high oil prices. Mainly owing to these windfall gains, oil exporters' aggregate current account surplus increased further in 2006 (to USD 422 billion) and now represents the largest counterpart to the US deficit. However, their imports have recently also increased as part of the additional oil revenue is being spent. This has helped sustain exports of the euro area, their closest trade partner. The yen's weakness, also against some regional currencies such as the

Korean won, helped the continued growth of Japanese exports.<sup>19</sup> Japan's exports to the rest of Asia grew at a particularly fast pace, indicating also the role of increased import demand in the region's striving emerging market economies. In contrast to other major global regions, the euro-area current account position continues to be close to balance.

124. **It is important that exchange rates reflect economic fundamentals.** Excess volatility and disorderly movements in exchange rates are undesirable for economic growth. Therefore, exchange markets are to be monitored closely. In emerging economies with large and growing current account surpluses, especially China, it is desirable that their effective exchange rates move so that necessary adjustments will occur.

125. **Global imbalances continue to represent a risk for exchange rate developments and worldwide economic growth.** The recent dollar depreciation increases the value in US dollar of US investment abroad while decreasing the value of foreigners' holding of US assets. Thereby, it limits the accumulation of US net external debt. However, in the long run, this mechanism cannot make the US current account deficit sustainable, because it would require foreigners to hold US assets that under-perform systematically compared to alternative investments. A failure to address global imbalances poses clear risks. These include a disorderly correction with undesirably large movements in exchange and interest rates, disruptive capital flow reversals and negative effects on investor confidence. Although the euro area's current account is close to balance, it would not be immune to the effects of a disorderly adjustment. Failure to address the global imbalances could also lead to rising protectionist pressures and prevent major trading partners from reaching an agreement on the Doha Development Agenda (DDA), which has the potential to contribute to global growth, promote development and contribute to the achievement of the Millennium Development Goals. Failure of the DDA could seriously affect the multilateral trading system. For these reasons, it is becoming more urgent to bring about the necessary adjustment of fundamentals

<sup>19</sup> Imports grew at roughly the same rate, so that the trade surplus was stable at just above 2% of GDP in 2006.

## Annual Report on the Euro Area

that would contribute to an orderly unwinding of global imbalances. This should accompany the resumption of the Doha Development Agenda.

126. *Between June 2006 and April 2007, the IMF organised a series of multilateral consultations on global imbalances.* These involved China, the euro area, Japan, Saudi Arabia and the US. The objective was to identify concrete policy measures aimed at implementing the broad consensus strategy agreed on by the IMFC/G7 to reduce global imbalances. At the spring meetings of the IMF in April 2007, the participants in the consultations announced a number of policy measures that are in each individual economy's interest and also desirable from a multilateral perspective. The implementation of these measures, which is to be monitored by the IMF, should make a significant contribution to the gradual resolution of global imbalances.

### 3.2 THE EURO AS A GLOBAL CURRENCY

127. *In the late 1990s the advent of EMU triggered a debate about the potential for the euro to challenge the role of the US dollar as a global currency.* Before the euro was launched in 1999, the United States' role in world production and trade, its stable economy and its broad and deep financial market favoured the US dollar as the leading international currency. While some argued that the dominant role of the US dollar would not diminish, others predicted that the euro would soon develop into an international currency whose importance and use would be commensurate to that of the US dollar. The optimistic predictions about the future international role of the euro were based on factors such as the relative size of the euro-area economy and its importance in global trade – the new single currency would represent the world's largest trading area – as well as a conviction that EMU would stimulate the integration and growth of euro-area financial markets while providing for monetary stability.

128. *Meanwhile, the euro has emerged as the second most important international currency behind the US dollar.* This reflects inter alia the euro-area's weight in the global economy and its importance in world trade. The

prominence of the euro extends to most of the different roles that a global currency can play in its international use by private sector participants (international borrowers, investors and traders) and official institutions (government authorities and central banks). The US dollar has preserved its prominent role in many areas – partly because of the natural advantage of incumbency – but its dominance has declined. As a rule, the euro is now the second most widely used currency among private sector participants in capital markets, foreign exchange markets and in international trade.

Graph 3.5: **International debt securities, amounts outstanding (stocks)\***  
(in % of total stocks of bonds notes and money market instruments – quarterly data 1994 Q1-2006 Q3)

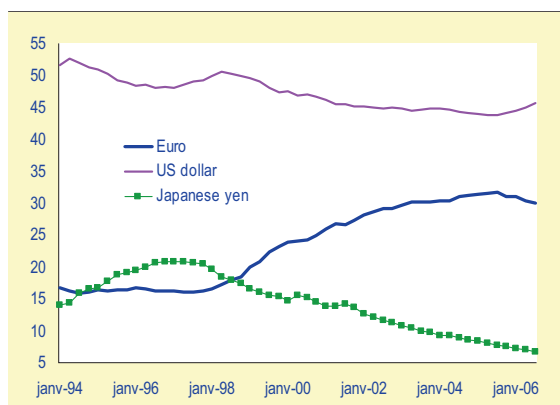

\*excluding home currency issuances.  
Source: ECB.

129. *The euro accounts for a substantial and increasing share of the stock of international debt securities,* which comprise instruments with both long-term (bonds and notes) and short-term maturities (money market instruments) (Graph 3.5). In particular, the wide use of the euro in international bond markets is a key feature of the euro's international role. Reflecting the opportunities created by deeper and more liquid capital markets in the euro area, the euro's share in gross issuance of short-term international debt securities surpassed that of the US dollar in 2006 (Table 3.1).





Table 3.1: Major currencies' shares in gross issuance of international debt securities

	Average 2004Q3- 2005Q2	2005Q3	2005Q4	2006Q1	2006Q2	2006Q3
<b>Short-term international debt securities</b>						
<b>Euro</b>	37.0	37.9	35.0	33.7	38.0	38.3
<b>US dollar</b>	39.6	36.5	39.2	40.2	36.5	37.9
<b>Japanese yen</b>	2.1	3.2	1.9	1.5	1.6	1.7
<b>Long-term international debt securities</b>						
<b>Euro</b>	35.6	30.3	25.1	28.7	26.9	28.5
<b>US dollar</b>	39.5	42.5	48.8	43.8	50.2	49.9
<b>Japanese yen</b>	6.2	7.0	5.3	4.3	3.9	3.8

Source: ECB based on BIS and ECB calculations.

130. *In foreign exchange markets, the euro is the second-most actively traded currency worldwide and accounts for roughly half of the US dollar's share* (Graph 3.6). A consequence of the euro-area's importance in world trade is that the euro is used extensively to quote, invoice and settle *international trade* transactions between the euro area and third countries and, in some cases, also between third countries. In most euro-area countries for which data are available, the share of euro-denominated exports and imports is above 50 per cent, for both goods and services. In *international commodity markets*, however, which are currently predominantly priced in US dollars, the impact of the euro has been limited. While oil and other commodity producers from time to time have declared their intentions to denominate their goods in euro, raw materials are still being predominantly priced in dollars. Factors such as inertia, tradition and the economic advantages of having a single currency of denomination have played an important role in this respect.

131. *The euro is widely used as an anchor or reference currency in foreign-exchange arrangements and as an official reserve currency.* The euro plays an important role as an *anchor* or *reference currency* in the managed exchange rate regimes of about 50 countries. Many of these countries are near the euro area, including most non euro-area EU Member States, or have special institutional arrangements with the EU, notably candidate countries, potential candidate countries and the countries of the CFA Franc-Zone. Although the US dollar remains the main currency of denomination of

*official foreign exchange reserves*, still accounting for about two-thirds of global official reserves, the share of the euro in global official reserves has been increasing gradually, from around 18% in 1999 to 25% in 2006 (Table 3.2).

Graph 3.6: Currency shares in the foreign exchange market  
(in % of total market turnover – annual data)

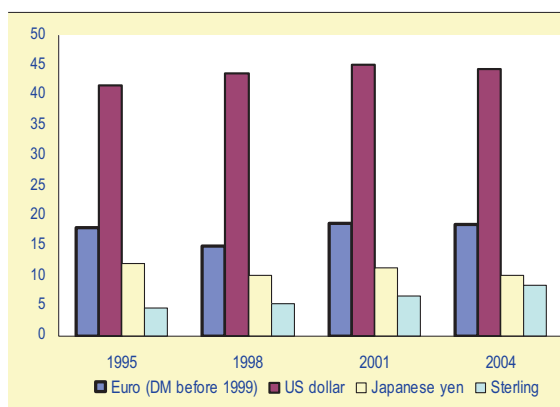

Source: BIS Triennial Survey 2005.

132. *The euro has the potential to further expand its international role.* The internationalisation of a currency is a gradual process, characterised by considerable inertia playing in favour of the incumbent currency. Nevertheless, the already significant and gradually expanding international use of the euro can be seen as a sign of confidence in the single currency and its underlying economic-policy framework. Therefore, the euro has the potential to grow further in its role as a key global currency.

## Annual Report on the Euro Area

Table 3.2: Currency shares in foreign exchange reserves\*

	Dec 01	Dec 02	Dec 03	Dec 04	Dec 05	Sep 06
<b>Global:</b>						
USD	71.4	67.0	65.9	65.8	66.6	65.6
EUR	19.2	23.8	25.2	24.9	24.3	25.2
<b>Industrialised countries:</b>						
USD	72.7	68.9	70.5	71.5	73.6	73.1
EUR	17.9	22.3	21.9	20.8	19.0	19.6
<b>Developing countries:</b>						
USD	70.1	65.2	61.3	60.2	60.7	60.1
EUR	20.6	25.4	28.5	29.0	28.7	29.4

\*disclosed currency composition at current exchange rates.

Source: ECB based on IMF and ECB calculations.

### 3.3 CHINA, INDIA AND RUSSIA – KEY ECONOMIC POWERS

133. *China, India and Russia have become major economic powers.* In terms of GDP growth since the early 1990s China and India rank first and second in the world while Russia has had high growth since 1999. Together with a few other rapidly growing emerging market economies, such as Brazil and South Africa, they are reshaping the world economy and have become key actors in the globalisation of production. Today, China, India and Russia are, in purchasing power parity terms, among the six largest economies in the world together with the EU, the US and Japan.

Graph 3.7: GDP growth rates of China, India and Russia (Annual data, 1980-2006)

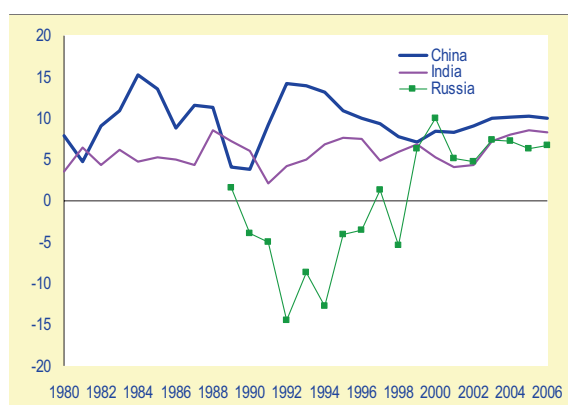

Source: Commission services, IMF.

134. *The observed acceleration of growth in China India and Russia is partly a response to the economic reform and liberalisation measures adopted by these countries.* With China's reforms having begun much earlier (in

the late 1970s) than in India and Russia (in the early 1990s), this helps to explain why China's improved growth performance significantly precedes that of the other two countries. China's per capita GDP is currently more than double that of India and roughly 60% of Russia's.

Graph 3.8: Degree of openness of China, India and Russia (Total trade/GDP, in % - annual data)

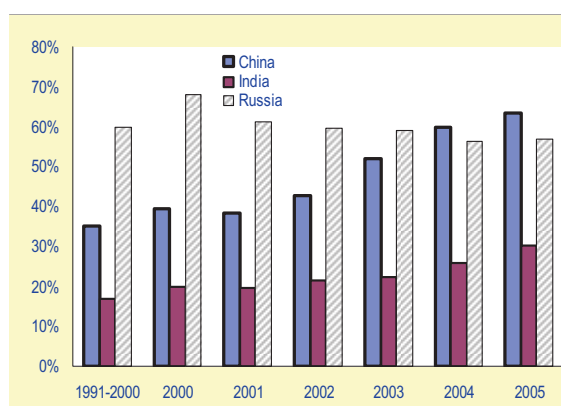

Source: EcoWin.

135. *The increasing importance of China, India and Russia for the world economy does not only stem from the rapid rates of growth they have exhibited in recent years.* It also reflects the fact that these economies are becoming increasingly integrated into the world economy, such as becoming key destinations for the outsourcing of productive processes by industrialised countries. As can be seen in Graph 3.8, the degree of openness of China, India and Russia, measured by the share of their exports plus imports over GDP has risen considerably. The increase in openness was particularly marked in the case of China (from an average of 35% in the 1990s to 63% in 2005).



136. *China's contribution to world-wide growth in the more recent past has indeed been impressive*, particularly considering the Asian financial crisis in 1997/98 and the worldwide slowdown following the bust of the IT-bubble in the United States in 2000. In real terms, GDP growth in China accelerated from 7.8% in 1998 to reach slightly more than 10% on average per year over the period 2003-2006. China's share in global output has risen from 1.7% in 1990 to 5% in 2005. Since 2000 the country has contributed about one third to overall worldwide GDP growth. Fixed asset investment, both in the industrial sector and in real estate, has contributed strongly to this impressive growth performance, as has the ongoing rise in exports, which are supported by a very competitive exchange rate. At the same time, the growth rate of private consumption has been much lower, as the lack of an adequate social security system keeps the savings ratio at high levels. As a consequence, the savings-investment gap has increased, driving up the current account surplus and foreign exchange reserves (Graph 3.9 and 3.10).

137. *Trade and investment flows between China and the euro area have been rising.* The euro area is a very important export destination for China, accounting for 19.4% of its total exports in 2005, equalling 9.7% of overall euro area imports in that year (Table 3.3) Although euro-area exports to China have also risen considerably, to EUR 43.5 billion in 2005, they remain modest as a percentage of total euro area exports. This suggests, however, a significant potential for further expansion. The euro-area trade deficit with China has kept growing, reaching slightly more than EUR 74 billion in 2005. Regarding, Foreign Direct Investment (FDI), euro-area flows to China have been rising both in absolute value and as a percentage of total euro-area outward FDI (Table 3.4). The euro area, however, remains a less important direct investment partner for China than the United States or Japan, which together accounted for 18.1% of China's total FDI inflows in 2005.

Graph 3.9: Foreign exchange reserves of China, India and Russia  
(Billions of USD - annual data)

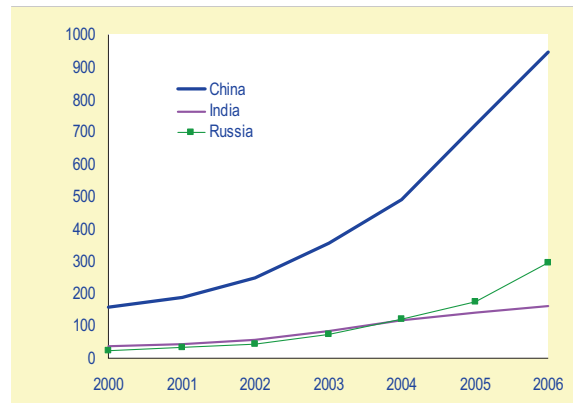

Source: EcoWin.

138. *Cooperation between EU and China is intense and is growing.* As strategic partners, the EU and China are already working together to promote world economic growth, sustainable development and macroeconomic stability. To this end, EU-China dialogues have been set up on a wide range of topics, from enterprise regulation to social security and macroeconomic policies. The annual macroeconomic and financial services dialogue between the EU and China – which has been taking place since 2005 between the Commission, the Chinese Ministry of Finance and the Chinese regulatory Commission – was complemented in 2006 by a dialogue with the Chinese National Development and Reform Commission.

Graph 3.10: Current account balances of China, India and Russia  
(% of GDP - annual data)

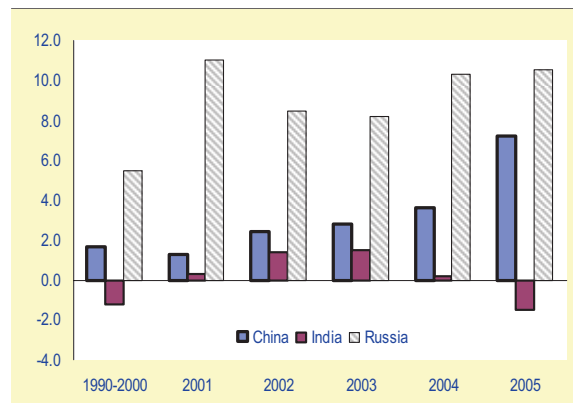

Source: IMF.

## Annual Report on the Euro Area

**Table 3.3 : Trade relationships between the euro-area and China/India/Russia** (Billions of EUR)

	1990-2000	2001	2002	2003	2004	2005
<b>Euro-area exports to China</b>	4,9	25,2	29,82	35	40,7	43,5
<i>% of total extra-euro-area exports</i>	1,8	2,4	2,8	3,3	3,5	3,5
Euro-area imports from China	24	57,1	61,8	74,5	93	117,6
<i>% of total extra-euro-area imports</i>	3,7	5,6	6,3	7,5	8,6	9,7
<i>% of China total exports</i>	21,5	27,0	23,8	21,3	19,7	19,4
<b>Euro-area exports to India</b>	6,2	8,8	10,2	9,9	12,2	15,3
<i>% of total extra-euro-area exports</i>	1,0	0,8	0,9	0,9	1,1	1,2
Euro-area imports from India	5,8	9,5	9,7	10	11,7	13,5
<i>% of total extra-euro-area imports</i>	0,9	0,9	1,0	1,0	1,1	1,1
<i>% of India total exports</i>	25,8	27,6	24,7	21,9	19,5	17,7
<b>Euro-area exports to Russia</b>	15	24,9	27,1	29,3	35,7	43,1
<i>% of total extra-euro-area exports</i>	2,2	2,3	2,5	2,8	3,1	3,5
Euro-area imports from Russia	21,5	42,8	42,1	47,4	56,4	73
<i>% of total extra-euro-area imports</i>	3,3	4,2	4,3	4,8	5,2	6,0
<i>% of Russia total exports</i>	28	46,5	37,3	41,0	42,7	38,2

**Source:** Commission services.

**Table 3.4 : Foreign Direct Investments between the euro-area and China/India/Russia**

	1996-2000	2001	2002	2003	2004	2005
<b>Euro area FDI flows to China (millions of EUR)</b>	1322	1038	1587	2724	2290	4625
<i>% of total extra-euro-area FDI outflows</i>	0,6	0,3	0,9	1,9	1,5	1,6
Total FDI inflows into China (millions of USD)	42696	46878	52743	53505	60630	72406
<b>Euro area FDI flows to India (millions of EUR)</b>	355	68	584	496	945	1389
<i>% of total extra-euro-area FDI outflows</i>	0,2	0,0	0,3	0,3	0,6	0,5
Total FDI inflows into India (millions of USD)	2906	5472	5627	4585	5474	6598
<b>Euro area FDI flows to Russia (millions of EUR)</b>	931	1475	2035	4154	2410	7595
<i>% of total extra-euro-area FDI outflows</i>	0,4	0,4	1,2	2,9	1,6	2,6
Total FDI inflows into Russia (millions of USD)	2524	2748	3461	7958	11672	14600

**Sources:** Commission services, UNCTAD.

139. *India has contributed to the reduction of the "Asian surplus" in the context of global current account imbalances.* The current account swung from a surplus in the fiscal year 2003/4 to a projected deficit of 1.3% of GDP in the fiscal year 2005/6 (Graph 3.10). This was primarily on the back of strong domestic demand and high oil prices.

140. *India's GDP has been growing at rates in the vicinity of 8% over the period 2002-2006,* with growth set to exceed 9% in fiscal year 2006/7 (April-March). Furthermore, growth is becoming more broad-based, as traditionally robust private consumption is now supported by buoyant investment activity (net FDI inflows increased by approximately 2.6 EUR billion over the last fiscal year to 2006/7) and a pick up in exports. As a result, the economy has been able



to withstand adverse global macroeconomic developments such as the slowdown of the US economy and increasing oil prices.

141. ***India is becoming a more important destination for the euro area's exports and FDI outflows*** (Tables 3.3 and 3.4). While euro-area exports to India are significant (more than EUR 15 billion in 2005, up by EUR 3 billion from the previous year), this only represents a 1.2% share of total extra-euro-area exports, which is low given the size of India's population and market. The same can be said for euro-area outward foreign direct investment (FDI) into India (at around EUR 1.4 billion in 2005). Hence, there is clearly scope for deepening trade and investment ties between India and the euro area.

142. ***Despite the economic successes to date, there are several risks to the sustainability of India's strong growth performance.*** These include large fiscal deficits (projected at 6 % of GDP for the fiscal year 2006/07) and high debt levels (projected at 80 % of GDP for fiscal year 2006/07). The more recent acceleration of India's rate of growth has had a negative impact on inflation and the current account. This could be a sign that the economy may be overheating. In combination with structural impediments, such as an excessive regulatory burden and labour market rigidities, this could negatively affect the investment climate. This contrasts to some extent with China where - despite the fears expressed by some analysts - inflation and the current account have not shown signs of deterioration despite the impressive recent growth performance.

143. ***Recent joint EU-India policy initiatives should contribute to further strengthening the bilateral relationship.*** The EU-India Summit of October 2006 agreed on the principle of concluding a Free Trade Agreement (FTA) between the two parties. A draft recommendation for a Council Decision authorising the Commission to negotiate a free trade agreement with India was adopted by the Commission in December of 2006. A regular macroeconomic dialogue between India and the European Union was also agreed upon at the EU-India Summit of October 2006 and will take place in July 2007 for the first time. It is also complemented by a specific dialogue on financial services, which started in June 2006.

144. ***Russia's growth has remained robust, in spite of the recent softening of energy prices.*** Russian GDP has fully recovered from the falls associated with the transition from planned to market economy and the 1998 crisis. While the average growth rate for the period 1990-1998 is a dismal -6.3%, the average growth rate for the period 1999-2006 is a robust +6.7%: the CIS is now the world's second fastest growing region, after East Asia. Real growth in Russia accelerated to 6.7% in 2006, from 6.4% in 2005. A significant part of the growth recovery is linked to higher energy prices, but accumulated structural reform and macroeconomic stabilization have generated broad-based growth: less than 30% of the growth observed between 2000 and 2006 is directly attributable to the energy sector. During most of this period, growth was increasingly driven by consumption and sustained by increasing export volumes. From 2005 onwards, with the reduction of the export volume growth - related to the sharp fall in the volume growth of oil exports - *net* exports started having a negative contribution to GDP. The main growth driver for 2006 became investment, reversing a previous relative underperformance of this item. Due to the oil price boom and the related large current account surplus (almost 10% of GDP on average since 2001), Russia now has the world 3<sup>rd</sup> largest foreign currency reserves, just after China and Japan (see Graph 3.9 and 3.10).

145. ***Russia is the 4<sup>th</sup> largest trading partner of the euro area.*** The euro area is the most important single trade partner of Russia, receiving 38% of its total exports in 2005. Russia provided 6% of the euro area total imports in that year (see Table 3.3), while the euro area supplied 43 EUR billion of exports to Russia (or 3.5% of the euro area total exports). This trade is very concentrated: most of the Russian exports to the euro area are energy products (around 60%). The euro-area trade deficit with Russia has almost doubled since the early 2000s, reaching around EUR 30 billion in 2005. Regarding FDI, the euro area is the single largest investor in Russia, climbing to over 61% in 2005 from around 47% in 2001. The 2005 value of euro area FDI in Russia was 64% higher than FDI into China. Total FDI inflows into Russia have risen substantially, reversing Russia's earlier relative under-performance in this area: in 2006, the share of FDI in GDP surpassed 3%, roughly the same share as in China.

## Annual Report on the Euro Area

146. *Also several EU-Russia dialogues have been set up on a wide range of topics, from enterprise regulation to macroeconomic policies.* An annual dialogue on macroeconomic, structural and financial services policies between the European Commission and the Russian Government was initiated in 2006. Russia is a EU strategic partner, most notably in the energy field, with which the EU intends to deepen its relationships, in particular through an enhanced partnership agreement and through the negotiations of a “deep” FTA that goes beyond simple market access and includes a significant degree of legislative and standards approximation after Russia accession to the WTO.

### 3.4 PROJECTING A STRONG VOICE ON THE WORLD STAGE

147. *The large and global role of the euro area and the euro call for an effective external representation.* Euro-area countries have a common interest and a common responsibility to monitor exchange rate developments and safeguard monetary and financial stability, both at home and on a global scale. This requires an enhanced representation for the euro area in international institutions and fora, in particular in the IMF and the G7. The objective of a consistent representation of the EU in the international economic and financial sphere has been politically backed by the conclusions of the 1998 Vienna European Council, where European leaders agreed on steps to ensure that the euro area speaks with one voice on issues of particular relevance to EMU.

148. *Over the last few years progress has been made in strengthening the external representation of the euro area.* This includes the creation of specialised committees in Brussels and Washington to coordinate Member State positions at the boards of the World Bank and the IMF, the participation of the ECB as an observer at the board of the IMF on euro-area related issues, the appointment of a two-year president of the Eurogroup and the full participation of the presidents of the Eurogroup and the ECB in the meetings of G-7 Finance Ministers.

149. *Still, the Community bodies of specific relevance to the euro area, i.e. the ECB, the Eurogroup president and the Commission, are represented to very different extents in the various international institutions and fora* (Table 3.5). At the IMF Board, for example, euro area countries continue to be dispersed over a large number of constituencies, some of which include non-EU countries, which makes it difficult to get a common position on some key IMF reform issues. All this tends to reduce the influence of the euro area in the IMF despite its significant aggregate voting power. The ECB’s observer status in the IMF Board is limited to euro-area related issues and multilateral surveillance sessions of relevance for the euro area. The Commission and the Eurogroup president are not represented at the IMF Board. Euro-area positions are presented to IMF Board by the Executive Director of the Member State holding the EU Presidency or the future holder of the Presidency in cases where non-euro area countries are in the Presidency chair. In the IMF’s International Monetary and Financial Committee (IMFC), the EU Presidency participates but not the president of the Eurogroup while the Commission and the ECB have only been granted an observer status. In the G7 Finance Ministers meetings, the ECB and the president of the Eurogroup now attend all agenda items while the Commission continues to participate only in a relatively limited part of the agenda, being often excluded from topics where it has Community competence. Furthermore, the Commission is not fully involved in the preparatory process leading to the G-7 ministerial meetings. In the same vein, the Commission is not a fully recognised participant in the G20, and attends only as part of the EU Presidency delegation, although it contributes on substance to the process. Moreover, the Eurogroup president does not attend the G20 at all, while the ECB fully participates. In the Financial Stability Forum (FSF), only the ECB participates while the Commission is the only major international financial regulatory body that is not involved in the FSF. The OECD is the only economic forum where all three relevant Community bodies are involved in discussions that are related to the euro area.



Table 3.5: External representation of the euro area: an overview

	Eurogroup Presidency	EU Presidency	European Central Bank	European Commission
OECD	<i>Participates in Economic and Development Review Committee examination of the euro area</i>		<i>Participation in Economic and Development Review Committee, Economic Policy Committee, and Committee on Financial Markets</i>	<i>Participation in all committees on behalf of the European Community</i>
IMF Executive Board		<i>Euro-area position represented by Executive Director holding EU/ euro-area Presidency</i>	<i>Observer status</i>	
International Monetary and Financial Committee		<i>Full participation depending on the constituency agreement</i>	<i>Observer status</i>	<i>Observer status</i>
Financial Stability Forum			<i>Full participation</i>	
G7 Finance Ministers	<i>Nearly full attendance</i>		<i>Nearly full attendance</i>	<i>Partial attendance; not involved in preparatory work</i>
G20		<i>Full participation</i>	<i>Full participation</i>	<i>Attends meetings as part of the EU Presidency delegation</i>

Source: Commission services.

150. *An issue which illustrates well the importance of an improved coordination among euro area and, more generally, EU countries, is the ongoing discussion on governance reform of the IMF.* At the Annual IMF/World Bank Meetings in September 2006 in Singapore, the IMFC approved a comprehensive program of internal IMF reforms to enhance the legitimacy, credibility and governance of the IMF. The reform started with a limited initial round of quota increases to address the legitimate claims of the four most underrepresented countries in the IMF, namely China, Korea, Mexico, and Turkey. Other elements of the reform, where further discussion is necessary, shall be completed within the next two years. They comprise:

- a revision of the current quota formula, making it simpler and more transparent and allocating a larger weight to GDP;
- further ad-hoc quota increases on the basis of the new formula, and a commitment to regular quota adjustments to ensure that quota shares evolve in line with economic developments;

- an increase in basic votes in the order of at least a doubling to enhance the representation of low-income countries in the Fund;
- a mechanism for preventing future erosion of voting shares of low-income countries; and,
- a review of the selection procedure of the Managing Director.

### 3.5 CONCLUSIONS

151. *Large global imbalances continue to pose serious risks for financial stability and the international trading system.* The changes in key exchange rates observed in 2006 have in general not gone in the direction or been of the magnitude warranted by current account disequilibria. The IMF's increased surveillance should therefore be welcomed as a step in the right direction to resolving these global issues. Tackling global imbalances is important not only to prevent a disorderly correction, which could

## Annual Report on the Euro Area

be very costly in terms of world growth and economic stability, but also because they risk feeding into protectionist sentiments. The multilateral consultations, in which the euro area is an active participant, are helping to improve the understanding and analysis of global imbalances

152. *The important international role of the euro is a sign of confidence in the euro and in its underlying policy framework.* While the dollar continues to benefit from incumbency, the euro is already playing a role in some areas, notably in bond markets and world trade, commensurate to that of the US dollar. And the international role of the euro has the potential to grow further. In this respect, future euro-area enlargements coupled with continued stability-oriented macroeconomic policies, growth-enhancing structural reforms and financial integration within the euro area will help to make the euro an even more attractive international currency.

153. *Trade and investment with China, Russia and India are important for the EU.*

The EU is responding by strengthening its bilateral framework of cooperation with these countries. As large emerging economies in the world, China's, Russia's and India's responsibilities now go beyond core bilateral issues to also include global challenges such as promoting world economic growth, sustainable development and macroeconomic stability.

154. *In October 2006, the Ecofin Council endorsed short-term measures aimed at strengthening external representation.* Nevertheless, the Community bodies of specific relevance to the euro area (i.e. the ECB, the Eurogroup president and the Commission) continue to be represented to very different extents in the various international institutions and forums. An issue which illustrates well the importance of better coordination among euro-area and, more generally, EU countries, is the ongoing discussion on governance reform of Bretton Woods institutions.



# List of contents of *European Economy*

## Basic editions

---

### 1, November 1978

- Annual Economic Report 1978–79
- Annual Economic Review 1978–79

### 2, March 1979

- European monetary system  
— Texts of the European Council of 4 and 5 December 1978

### 3, July 1979

- Short-term economic trends and prospects
- The European monetary system  
— Commentary  
— Documents

### 4, November 1979

- Annual Economic Report 1979–80
- Annual Economic Review 1979–80

### 5, March 1980

- Short-term economic trends and prospects
- Adaptation of working time

### 6, July 1980

- Short-term economic trends and prospects — Borrowing and lending instruments looked at in the context of the Community's financial instruments

### 7, November 1980

- Annual Economic Report 1980–81
- Annual Economic Review 1980–81

### 8, March 1981

- Economic trends and prospects — The Community's borrowing and lending operations recent developments

### 9, July 1981

- Fifth medium-term economic policy programme — The main medium-term issues: an analysis

### 10, November 1981

- Annual Economic Report 1981–82
- Annual Economic Review 1981–82

### 11, March 1982

- Economic trends and prospects — Unit labour costs in manufacturing industry and in the whole economy

### 12, July 1982

- Documents relating to the European monetary system

### 13, September 1982

- The borrowing and lending activities of the Community in 1981

### 14, November 1982

- Annual Economic Report 1982–83
- Annual Economic Review 1982–83

### 15, March 1983

- Economic trends and prospects — Budgetary systems and procedures — Industrial labour costs — Greek capital markets

### 16, July 1983

- Business investment and the tax and financial environment — Energy and the economy: a study of the main relationships in the countries of the European Community — The foreign trade of the Community, the United States and Japan

### 17, September 1983

- The borrowing and lending activities of the Community in 1982

### 18, November 1983

- Annual Economic Report 1983–84
- Annual Economic Review 1983–84

### 19, March 1984

- Economic trends and prospects — Industrial labour costs — Medium-term budget balance and the public debt — The issue of protectionism

### **20, July 1984**

- Some aspects of industrial productive performance in the European Community: an appraisal — Profitability, relative factor prices and capital/labour substitution in the Community, the United States and Japan, 1960–83 — Convergence and coordination of macroeconomic policies: some basic issues

### **21, September 1984**

- Commission report to the Council and to Parliament on the borrowing and lending activities of the Community in 1983

### **22, November 1984**

- Annual Economic Report 1984–85
- Annual Economic Review 1984–85

### **23, March 1985**

- Economic trends and prospects 1984–85

### **24, July 1985**

- The borrowing and lending activities of the Community in 1984

### **25, September 1985**

- Competitiveness of European industry: situation to date — The determination of supply in industry in the Community — The development of market services in the European Community, the United States and Japan — Technical progress, structural change and employment

### **26, November 1985**

- Annual Economic Report 1985–86
- Annual Economic Review 1985–86

### **27, March 1986**

- Employment problems: views of businessmen and the workforce — Compact — A prototype macroeconomic model of the European Community in the world economy

### **28, May 1986**

- Commission report to the Council and to Parliament on the borrowing and lending activities of the Community in 1985

### **29, July 1986**

- Annual Economic Review 1986–87

### **30, November 1986**

- Annual Economic Report 1986–87

### **31, March 1987**

- The determinants of investment — Estimation and simulation of international trade linkages in the Quest model

### **32, May 1987**

- Commission report to the Council and to Parliament on the borrowing and lending activities of the Community in 1986

### **33, July 1987**

- The economy outlook for 1988 and budgetary policy in the Member States — Economic trends in the Community and Member States

### **34, November 1987**

- Annual Economic Report 1987–88

### **35, March 1988**

- The economics of 1992

### **36, May 1988**

- Creation of a European financial area

### **37, July 1988**

- Commission report to the Council and to Parliament on the borrowing and lending activities in the Community in 1987

### **38, November 1988**

- Annual Economic Report 1988–89

### **39, March 1989**

- International trade of the European Community

### **40, May 1989**

- Horizontal mergers and competition policy in the European Community

### **41, July 1989**

- The borrowing and lending activities of the Community in 1988 — Economic convergence in the Community: a greater effort is needed

#### **42, November 1989**

- Annual Economic Report 1989–90

#### **43, March 1990**

- Economic transformation in Hungary and Poland

#### **44, October 1990**

- One market, one money

#### **45, December 1990**

- Stabilisation, liberalisation and devolution

#### **46, December 1990**

- Annual Economic Report 1990–91

#### **47, March 1991**

- Developments on the labour-market in the Community — Quest — A macroeconomic model for the countries of the European Community as part of the world economy

#### **48, September 1991**

- Fair competition in the international market: Community State aid policy — The ecu and its role in the process towards monetary union

#### **49, 1993**

- Reform issues in the former Soviet Union

#### **50, December 1991**

- Annual Economic Report 1991–92

#### **51, May 1992**

- The climate challenge: Economic aspects of the Community's strategy for limiting CO<sub>2</sub> emissions

#### **52, 1993**

- The European Community as a world trade partner

#### **53, 1993**

- Stable money — sound finances: Community public finance in the perspective of EMU

#### **54, 1993**

- Annual Economic Report for 1993

#### **55, 1993**

- Broad economic policy guidelines and convergence report

#### **56, 1994**

- Annual Economic Report for 1994

#### **57, 1994**

- Competition and integration — Community merger control policy

#### **58, 1994**

- 1994 broad economic policy guidelines — Report on the implementation of macrofinancial assistance to third countries

#### **59, 1995**

- Annual Economic Report for 1995

#### **60, 1995**

- 1995 broad economic policy guidelines

#### **61, 1996**

- Annual Economic Report for 1996

#### **62, 1996**

- 1996 broad economic policy guidelines

#### **63, 1997**

- Annual Economic Report for 1997

#### **64, 1997**

- 1997 broad economic policy guidelines

#### **65, 1998**

- Commission's recommendation concerning the third stage of economic and monetary union — Convergence report 1998 — Growth and employment in the stability-oriented framework of EMU

#### **66, 1998**

- 1998 broad economic policy guidelines

#### **67, 1999**

- 1999 Annual Economic Report

## **68, 1999**

- 1999 broad economic policy guidelines

## **69, 1999**

- The EU economy: 1999 review

## **70, 2000**

- 2000 broad economic policy guidelines — Convergence report 2000 — Proposal for a Council decision for the adoption by Greece of the single currency on 1 January 2001

## **71, 2000**

- The EU economy: 2000 review

## **72, 2001**

- 2001 broad economic policy guidelines

## **73, 2001**

- The EU economy: 2001 review  
Investing in the future

## **Reports and studies**

---

### **1-1993**

- The economic and financial situation in Italy

### **2-1993**

- Shaping a market economy legal system

### **3-1993**

- Market services and European integration: the challenges for the 1990s

### **4-1993**

- The economic and financial situation in Belgium

### **5-1993**

- The economics of Community public finance

### **6-1993**

- The economic and financial situation in Denmark

### **1-1994**

- Applying market principles to government borrowing — Growth and employment: the scope for a European initiative

### **2-1994**

- The economic and financial situation in Germany

### **3-1994**

- Towards greater fiscal discipline

### **4-1994**

- EC agricultural policy for the 21st century

### **5-1994**

- The economics of the common agricultural policy (CAP)

### **6-1994**

- The economic interpretation between the EU and eastern Europe

### **7-1994**

- The economic and financial situation in Spain

### **1-1995**

- The economic and financial situation in the Netherlands

### **2-1995**

- Report on the implementation of macrofinancial assistance to the third countries in 1994

### **3-1995**

- Performance of the European Union labour market

### **4-1995**

- The impact of exchange-rate movements on trade within the single market

### **1-1996**

- The economic and financial situation in Ireland. Ireland in the transition to EMU

### **2-1996**

- The CAP and enlargement — Economic effects of the compensatory payments

### **3-1996**

- Ageing and pension expenditure prospects in the western world

### **4-1996**

- Economic evaluation of the internal market

### **1-1997**

- The economic and financial situation in Portugal in the transition to EMU

### **2-1997**

- The CAP and enlargement — Agrifood price developments in five associated countries

### **3-1997**

- The European Union as a world trade partner

### **4-1997**

- The welfare state in Europe — Challenges and reforms

### **5-1997**

- Towards a common agricultural and rural policy for Europe

### **6-1997**

- The joint harmonised EU programme of business and consumer surveys

### **1-1998**

- Getting environmental policy right — The rational design of European environmental policy

### **2-1998**

- The economic and financial situation in Austria

### **3-1998**

- Income benefits for early exit from the labour market in eight European countries — A comparative study

### **1-1999**

- The economic and financial situation in Finland

### **2-1999**

- Income insurance in European agriculture

### **3-1999**

- State aid and the single market

### **4-1999**

- Liberalisation of network industries

### **5-1999**

- Italy's slow growth in the 1990s

### **6-1999**

- Generational accounting in Europe

### **1-2000**

- The report on the implementation of the 1999 broad economic policy guidelines

### **2-2000**

- Public debt and fiscal policy in EMU

### **3-2000**

- Public finances in EMU — 2000

### **4-2000**

- Performance of the European Union labour market — Joint harmonised EU programme of business and consumer surveys

## **1-2001**

- Current issues in economic growth

## **2-2001**

- Report on the implementation of the 2000 broad economic policy guidelines

## **3-2001**

- Public finances in EMU — 2001

## **4-2001**

- The budgetary challenges posed by ageing populations

## **5-2001**

- The efficiency defence and the European system of merger control

## **Special editions**

---

### **Special issue 1979**

- Changes in industrial structure in the European economies since the oil crisis 1973–78 — Europe — its capacity to change in question

### **Special edition 1990**

- The impact of the internal market by industrial sector: the challenge for the Member States

### **Special edition No 1/91**

- The economics of EMU

### **Special edition No 2/91**

- The path of reform in central and eastern Europe

### **Special edition No 1/92**

- The economics of limiting CO<sub>2</sub> emissions
- 

## **New numbering**

### **2002**

## **1-2002**

- Report on the implementation of the 2001 broad economic policy guidelines

## **2-2002**

- Economic forecasts — Spring 2002

## **3-2002**

- Public finances in EMU — 2002

## **4-2002**

- 2002 broad economic policy guidelines

## **5-2002**

- Economic forecasts — Autumn 2002

## **6-2002**

- The EU economy: 2002 review

## **Special Report No 1/2002**

- Responses to the challenges of globalisation

## **Special Report No 2/2002**

- European integration and the functioning of product markets

## 2003

### **1-2003**

- Report on the implementation of the 2002 broad economic policy guidelines

### **2-2003**

- Economic forecasts — Spring 2003

### **3-2003**

- Public finances in EMU — 2003

### **4-2003**

- Broad economic policy guidelines (for the 2003–05 period)

### **5-2003**

- Economic forecasts — Autumn 2003

### **6-2003**

- The EU economy: 2003 review

## 2004

### **1-2004**

- Report on the implementation of the 2003–05 broad economic policy guidelines

### **2-2004**

- Economic forecasts — Spring 2004

### **3-2004**

- Public finances in EMU — 2004

### **4-2004**

- The 2004 update of the broad economic policy guidelines (for the 2003–05 period)

### **5-2004**

- Economic forecasts — Autumn 2004

### **6-2004**

- The EU economy: 2004 review

### **Special Report No 1/2004**

- EMU after five years

### **Special Report No 2/2004**

- Convergence report 2004

### **Special Report No 3/2004**

- Quality and efficiency in education

## **1-2005**

- Second report on the implementation of the 2003–05 broad economic policy guidelines

## **2-2005**

- Economic forecasts — Spring 2005

## **3-2005**

- Public finances in EMU — 2005

## **4-2005**

- The broad economic policy guidelines (for the 2005–08 period)

## **5-2005**

- Economic forecasts — Autumn 2005

## **6-2005**

- The EU economy: 2005 review

## **1-2006**

- Convergence report — December 2006

## **2-2006**

- Economic forecasts — Spring 2006

## **3-2006**

- Public finances in EMU — 2006

## **5-2006**

- Economic forecasts — Autumn 2006

## **6-2006**

- The EU economy: 2006 review

## **2005**

### **Special Report No 1/2005**

- The contribution of wage developments to labour market performance

### **Special Report No 2/2005**

- Indicators and policies to make work pay

### **Special Report No 3/2005**

- Labour market and wage developments in 2004 with special focus on the risk of jobless growth

### **Special Report No 4/2005**

- Ageing populations: underlying assumptions and projection methodologies to be used in the age-related expenditure projections for EU-25 Member States (2004–50)

## **2006**

### **Special Report No 1/2006**

- The impact of ageing on public expenditure: projections for the EU-25 Member States on pensions, healthcare, long-term care, education and unemployment transfers (2004–50)

### **Special Report No 2/2006**

- 2006 Convergence report on Lithuania
- 2006 Convergence report on Slovenia

### **Special Report No 3/2006**

- Annual report on the euro area

### **Special Report No 4/2006**

- Labour market and wage developments in 2005, with special focus on labour market adjustment in the euro area

### **Special Report No 5/2006**

- The joint harmonised EU programme of business and consumer surveys



# ORDER FORM

---

## for European Economy

Office des  
publications officielles  
des Communautés européennes

L-2985      **Luxembourg**

---

### ORDER FORM — Annual subscription

**European Economy**  
**Main issues**

ISSN 0379-0991

**Special reports**

ISSN 1684-033X

Price of annual subscription (six issues minimum per year):  
EUR 150

Number  
of copies:

.....

.....

Name and address:

Date:

Signature: .....

---

### ORDER FORM — Single issue

**European Economy**  
**Main issue**

ISSN 0379-0991

ISBN .....

**Special report**

ISSN 1684-033X

ISBN .....

Title requested .....

Price of single issue: EUR 50

Number  
of copies:

.....

.....

Name and address:

Date:

Signature: .....

Office des publications officielles  
des Communautés européennes

**L-2985 Luxembourg**

Office des publications officielles  
des Communautés européennes

**L-2985 Luxembourg**

Want to keep track of the European Union's activities?

On the Internet, consult the *Bulletin of the European Union*, the source of information on the Union's activities.

The *Bulletin of the European Union* provides a monthly insight into the activities of the European Commission and of the other Community institutions. It is published by the Secretariat-General of the Commission and appears 10 times a year in French, English and German. The Bulletin is supplemented by the *General Report on the Activities of the European Union*, which provides an overview of the activities of the previous year.







*European Economy* appears six times a year. It contains important reports and communications from the Commission to the Council and the Parliament on the economic situation and developments ranging from the *Broad economic policy guidelines* and its implementation report to the *Economic forecasts*, the *EU Economic review* and the *Public finance report*. As a complement, *Special reports* focus on problems concerning economic policy.

Subscription terms are shown on the back cover and details on how to obtain the list of sales agents are shown on the inside back cover.

Unless otherwise indicated the texts are published under the responsibility of the Directorate-General for Economic and Financial Affairs of the European Commission, BU1, B-1049 Brussels, to which enquiries other than those related to sales and subscriptions should be addressed.

**Price (excluding VAT) in Luxemburg: EUR 50**

---

European Economy (6 issues minimum per year): EUR 150.

The annual subscription runs from 1 January to 31 December of each year.

Payments to be made only to sales agents on the list (see inside back cover for details).

These are surface mail rates; for air subscription rates please apply to the sales offices.

[http://ec.europa.eu/economy\\_finance](http://ec.europa.eu/economy_finance)

---



ISBN 978-92-79-04950-7



9 789279 049507