

The views expressed in this report, as well as the information included in it, do not necessarily reflect the opinion or position of the European Commission and in no way commit the institution.

Advanced Manufacturing

Measurement Technologies & Robotics

Business Innovation Observatory
Contract No 190/PP/ENT/CIP/12/C/N03C01

Authors: Laurent Probst, Erica Monfardini, Laurent Frideres, Steven Clarke, Dawit Demetri & Alain Kauffmann, PwC Luxembourg.

Coordination: Directorate-General for Enterprise and Industry, Directorate B “Sustainable Growth and EU 2020”, Unit B3 “Innovation Policy for Growth”.

European Union, September 2013.

Table of Contents

1. Executive summary	2
2. Automation using measurement technologies and robotics	3
2.1. Measurement Technologies	3
2.2. Robotics	4
2.3. Advantages of these automation solutions	5
3. Socio-economic relevance	6
3.1. Demand for these automation solutions	6
3.2. Examples of novel successful measurement technologies and robotics solutions	7
3.3. Socio-economic impacts of measurement and robotics solutions	11
3.4. Market adoption	12
3.5. Uptake of automation solutions by SMEs in the manufacturing sector	12
4. Drivers and obstacles	14
4.1. Proof of concept improves access to finance	14
4.2. Industrial partnerships help get a foothold into the market	14
4.3. A local knowledge and culture conducive to development of these technologies	15
4.4. Support schemes supporting innovative start-ups	15
5. Policy recommendations	16
5.1. Promoting R&D in measurement technologies and robotics	16
5.2. Raising awareness of the benefits of automation	17
5.3. Improving support of start-ups	17
6. Appendix	18
6.1. Interviews	18
6.2. Websites	18
6.3. References	18

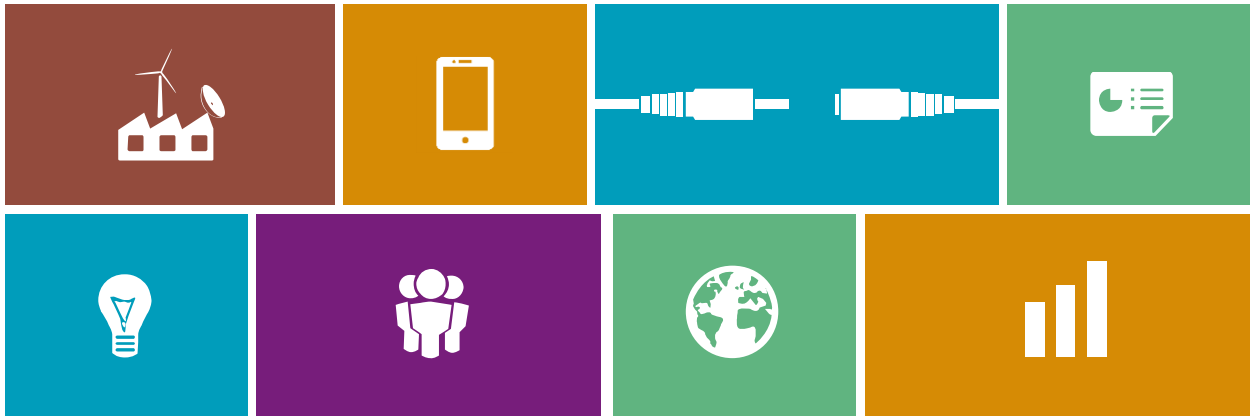

1. Executive summary

Faced with the mounting challenges posed by international competitors, Europe's industrial sector has sought to innovate by employing automation solutions that provide manufacturers with the means to increase their productivity by improving the quality and consistency of their products while reducing their operating costs. Further to this, manufacturers also employ automation solutions in order to offer health and safety benefits, as they remove the need for humans to work in hazardous or unsafe environments, as well as environmental benefits, in the form of more energy efficient production processes. For example, some industrial robots are able to operate on assembly lines without lighting.

Measurement technologies and robotics are two of the latest trends in automation, both of which have the potential to improve the productivity of European manufacturing. Measurement technologies, typically used for operational or regulatory purposes, improve the accuracy of data collated during the manufacturing process and enhance the production line's process control features. These features provide information about a dynamic variable (e.g. pressure, temperature and speed) that is ultimately controlled. These measurements are then translated into a signal processed by the control system, which assesses whether the measured value is in line with the desired value and takes action in order to remove or reduce variability. Action is taken via a feedback loop, whereby the device in question accepts a signal from the controller in order to adjust the manufacturing process according to pre-determined specifications.

In the case of robotics, which involves the design, construction and implementation of machines to perform tasks traditionally conducted by humans, manufacturing processes benefit most from improved flexibility. Robots are flexible in that they can easily change their function in order to meet the demands of the manufacturer or the client. In doing so, robots essentially perform three tasks, as they

“sense” by drawing on environmental stimuli, then “think” by using pre-set algorithms for planning and finally “act”, using the robots' end-effector (e.g. a clamp or welding torch) to pick up and place an object or weld two objects together. Yet in spite of such developments in measurement technologies and robotics, the adoption of automation solutions is constrained by two factors, namely: their particular dependence on the automotive sector in Europe; and their limited application by SMEs, who deem it inappropriate to integrate capital-intensive robots into their small-scale manufacturing processes.

Countering these obstacles are a number of trend drivers, including Europe's advanced research and development activities in the fields of metrology and robotics, which have led to the emergence of several European clusters of excellence in the field. Furthermore, industrial partners have supported Europe's academic excellence in these two fields by providing researchers with funding and a channel for market entry. Lastly, the public sector has also played a key role in supporting start-ups bring their innovative measurement technologies and robotics solutions to market.

To enhance its role in promoting the uptake of measurement technologies and robotics, the public sector should explore three strategic avenues. First of all, policy makers should assess how the public sector can best assist innovative businesses in bringing their measurement technologies and robotics solutions to market. Secondly, the public sector ought to investigate how it can use awareness raising activities to catalyse the market for measurement technologies and robotics solutions. Finally, the public sector could explore what support schemes innovative start-ups need, for instance, in areas related to business plan development or intellectual property. Should the public sector do so, Europe would be well-placed to capture a sizeable share of the world's EUR 55.2 billion automation market.



2. Automation using measurement technologies and robotics

Automation is the use of machines, control systems and IT solutions to improve the productivity of an industrial process that would otherwise be done manually. It should not be confused with mechanisation, which comprises mechanical solutions operated by workers as part of the manufacturing process. Where automation differs from mechanisation is that automation removes the need for workers to operate the machinery while increasing load capacity, speed, and repeatability. The key milestones in automation until now are listed in Table 1.

Table 1: The key milestones of automation

Date	Development
1920-1940	Transfer machines; mass production.
1940	First electronic computing machine.
1943	First digital electronic computer.
1947	Invention of the transistor.
1952	First prototype numerical control machine tool.
1954	Development of the symbolic language APT (Automatically Programmed Tool); adaptive control.
1957	Commercially available NC machine tools.
1960	Industrial robots.
1965	Large-scale integrated circuits.
1968	Programmable logic controllers.
1970s	First integrated manufacturing system; spot welding of automobile bodies with robots; microprocessors; minicomputer-controlled robot; flexible manufacturing system; group technology.

Source: Kalpakjian and Schmid (2008)¹

Today, automation and process integration in manufacturing is continuously improving as a result of technological developments. This case study will cover two new trends in automation solutions for manufacturing: the use of **measuring technologies** and the implementation of new **robotics** solutions.

2.1. Measurement Technologies

Measurement as an activity can be found inside every manufacturing organisation². This includes measurements for internal regulations to comply with rules that govern operations within the company such as health and safety. Measurements for external regulations comprise activities to ensure compliance with rules that govern the effects of operations on their external environment, such as the checking of green-house gas emissions. Operational measurements concern the measurement of the production process in order to ensure its correct operation and the quality of the product. Finally, there may be activities in an organisation directed towards the improvement of current measurement systems, through in-house R&D.

All of these measurement requirements are necessary to the organisation's success. Having reliable results of measurement and tests is therefore very important in order to ensure compliance with regulations. If it does not invest in these, it may not adhere to Good Manufacturing Practices (including health and safety regulations or environmental regulations) and be sanctioned as a result. At the same time, it is important to ensure operational measurements in order to make sure that production meets national standards. Without which, the company may be at a competitive disadvantage.

Within this trend of recent technological developments in measurement technologies there have been two new advances that affect automation. First, there are new, more powerful and sophisticated measurement technologies that are becoming available on the market. These new measurement technologies either enable the measurement of previously immeasurable data, or improve on conventional measurement solutions by providing unprecedented amounts of precision, accuracy and repeatability. They also allow to better measure different aspects of automation. In addition, measurement technologies can now be used in novel ways in automated processes, in particular in process control. In order to illustrate this second development, it is important to understand the control procedure before acknowledging to what extent automation and advanced measurement technologies bring value to this procedure.



The process-control loop, which is graphically represented in Figure 1, is defined as:

- **The process:** This is the manufacturing process itself, which can be the assembly of equipment, input of material, use of workers in order to produce the output i.e. the product. The process can be exposed to disturbances from both internal sources that are under the producers control, and external ones.
- **Measurement:** A measurement provides information about a dynamic variable (or variables) in the process which is (are) to be controlled. These measures can be for a variety of things like pressure, temperature, flow, position, speed, etc. Within an automated manufacturing system, this measurement is then translated into an analogue or digital signal to be processed by the control system.
- **Evaluation:** Within this stage, the controller compares the result of the measurement with that of the desired value and based on it determines the response in order to remove or reduce any variability.
- **Control:** The control element in the feedback loop is the stage where the action to be taken as determined in the evaluation by the controller, is fed back into the process to a control device. This can consist of a control device like a valve, a motor, a pump or a brake, for example. The control device accepts a signal from the controller in order to adjust the process according to specifications.

Figure 1: The process control loop

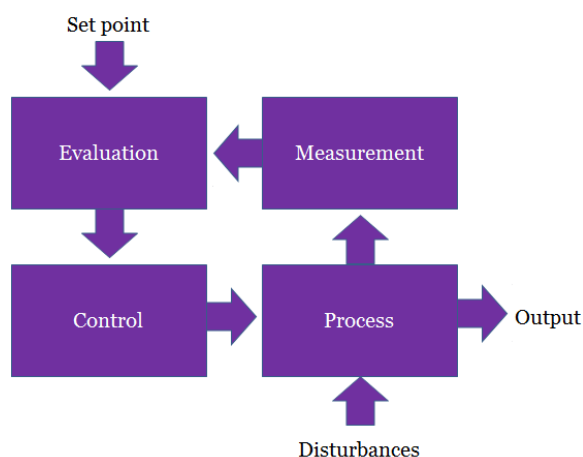

Source: Swann (2009)

Despite the increasing importance of automation in manufacturing, the taking of measurements for process control has predominately been done manually³. Measurements of quality control, machine status and rates of production for instance have almost always relied on either a manual operation of a machine or of a worker physically taking measurements.

Rather than this conventional ad hoc use of discrete conventional measurements, new solutions can be integrated as part of process control across the entire manufacturing process line. This can cover the input of feedstock or material input, to the final product output. This use of measurement technologies is important as measurement constitutes one of the 4 stages in process control loops in automated systems, as demonstrated earlier. The device used for such measurements could be a robot, a pump, a quality control instrument, a pressure valve or a thermometer, to list a few examples of the many different tools that play a role in production.⁴

2.2. Robotics

Robotics is the design, construction and use of machines to perform tasks done traditionally by human beings. According to the International Federation of Robots (IFR), an **industrial robot** is defined as “an automatically controlled, reprogrammable, multipurpose manipulator programmable in three or more axes, which may be either fixed in place or mobile for use in industrial automation applications”⁵.

Industrial robots differ from **service robots**, in that the latter are not involved in manufacturing operations. Since the present case study covers the trend of the use of robotics in automation solutions in manufacturing, it will concentrate on the developments in industrial robotic solutions rather than service robotics.

Robots have mostly been used since they were first invented over the last 50 years in industrial manufacturing⁶. However, despite promises of an industrial revolution as a result of the emergence of this technology, the best known uses of robotics in manufacturing is in the automotive industry⁷ (Figure 2). These industrial robots are for the most part programmed to carry out specific repetitive actions with little variation, but with a high degree of precision and accuracy.

Figure 2: Spot-welding performed by robots on an assembly line



Source: Kalpakjian and Schmid (2008)



As part of their function, robots essentially perform three tasks. They “sense” “think” and “act” (Figure 3). Robots “sense” environmental stimuli. From this, they “think” through pre-set algorithms for planning. Their reaction to stimuli is determined by these algorithms, which is then translated into physical movement (“act”). Using the robots’ “end effector”, which can be a clamp or a welding torch, this action could range from picking up an object and placing it into another tray, or welding two pieces of metal together.

Figure 3: Basic robotic functions with examples

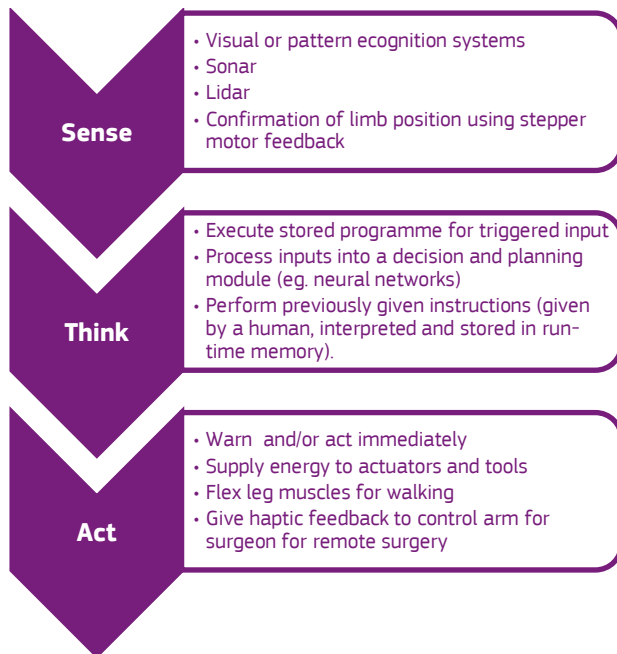

Source: Forge and Blackman (2010)⁶

The latest advances in robotics have aimed to bring robot solutions **to industries where they could not be used beforehand** such as waste management, packaging and food processing. These new, more powerful solutions are able to identify different object orientations and even material types, adjusting their behaviour accordingly.

Some new robots have been developed that provide their users with more **flexibility** through more intuitive and simplified means of re-programming the robot and its functions. In addition, there are developments in robotics to allow robots and workers to work together in the same space. Normally, industrial robots pose a threat to workers as they can be powerful and unable to register physical obstructions, like a person. This means that generally, production floors with industrial robots are clear of workers during operation, or that these robots are in cages. New developments in robotics allow workers to work within the same environment as robots safely, and even collaborate with one another.

2.3. Advantages of these automation solutions

Measurement technologies aim to ensure quality and compliance with standards and regulations, whilst robotics can provide solutions to improve the manufacturing process. The latest developments in these two novel technologies combined together is a new trend in advanced manufacturing technologies, as manufacturers seek to achieve a **competitive advantage**.

Automation of the manufacturing or other industrial processes can help **improve the consistency of processes and products**. The mechanisation of stations in a production line can remove some of the variables that can be attributed to human error. For example, workers on a production line can become tired or bored whilst performing monotonous tasks. Removing the variability as a result of human error can help standardise both the manufacturing process and the product.

In addition to removing human error, the automation of manufacturing can **improve product quality** as a result of increased precision in production. For example, some new measurement tools can provide an even more accurate estimation of the product quality, thus making it a superior product. Whilst robots could be implemented to perform a task with a high degree of precision (e.g. perform a cut-out from a mould).

Automation of manufacturing can help **reduce costs**. For example a robot could be programmed by a worker, to perform a task, allowing the worker to be reallocated to another more important tool. Another example of how automation could help reduce cost would be through the use of integrated measurement solutions. These could autonomously take measurements and only require the attention of workers when necessary, such as in the event of an error or a faulty product.

Measurement technologies could be implemented in order to better understand the performance or status of all the different devices within the manufacturing process. This would allow to better predict jams, or breakdowns, allowing to tailor maintenance strategies accordingly. Integrating measurements within production as it goes on would also help reduce time lost correcting production errors, thus minimising time spent producing the end-product.

Automation solutions can have **health and safety benefits**, removing the need for workers to operate in hazardous or unsafe environments (e.g. exposure to toxic fumes or extreme temperatures). In addition, they can remove the burden of heavy and repetitive labour that could result in injury.



The use of automation can have **environmental benefits**, through more energy efficient production processes. For example, some industrial robots can operate on an assembly line without the need for lighting, saving energy. Measurement technologies can also provide a better feedback as to the environment in which workers operate, reducing risk from exposure to harmful environments. In

addition new measurement technologies can help provide better solutions so as to measure with more precision the environmental impact of production.

Ultimately automation solutions help manufacturers **increase their productivity**, through a reduction of inputs like energy requirements or production errors, while improving production output, produce quality and consistency.

3. Socio-economic relevance

The manufacturing sector in Europe faces ever-increasing competition in the global markets. Competition in high-tech industries exists from other developed economies such as the U.S., Japan and Korea within the same industry sector, as well as in other industry sectors from emerging markets. To remain competitive in this global market, European manufacturing has to address the challenge of producing more products with less material, whilst consuming less energy and generating less waste. Manufacturing has to innovate in order to meet these expectations, and one of the innovations that will help them do so will be through the use of new innovative automation solutions. The key indicators for European manufacturing are shown in Table 2.

Table 2: Key indicators for European manufacturing in 2010

Indicator	Units	Value
Number of enterprises	thousands	2,130
Persons employed	thousands	30,000
Turnover	EUR million	6,410,000
Purchases of goods and services	EUR million	4,810,000
Personnel costs	EUR million	1,010,000
Value added	EUR million	1,590,000
Gross operating surplus	EUR million	580,000
Share of non-financial business economy:		
- no. of enterprises	%	9.8
- employment	%	22.6
- value added	%	26.8
- Apparent labour productivity	EUR / 1000 persons	52.8
- Average personnel costs	EUR / 1000 persons	35.8
- Gross operating rate	%	9.0

Source: Eurostat (2013)⁸

3.1. Demand for these automation solutions

The global market for automation solutions is estimated at EUR 55.2 billion, with the most important end-market being the automotive industry, accounting for 34% of the market (Figure 4)⁹. The Western European markets account for 17% of the global market for automation solutions. Other important end-markets for automation solutions include Packaging (19%), Textiles (12%) and Food Processing (6%).

Figure 4: The size of the automation market

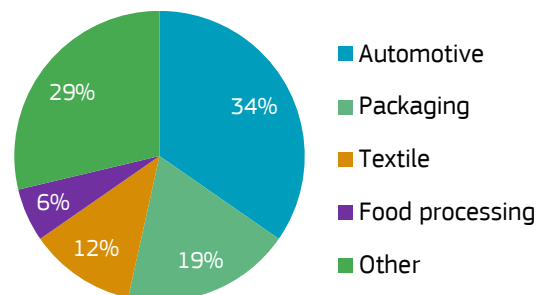

Source: Credit Suisse (2012)

Today, manufacturing in Europe is undergoing a change in order to remain competitive on the global market¹⁰. In countries such as Germany, instead of competing with low-cost importers for lower end products, manufacturers are targeting more high-end products, such as engines, turbines and flow control equipment.

Manufacturers are also offering hybrid-value added products (e.g. temperate control, as opposed to just heating equipment), offering solutions to a need rather than simple industrial products as a response to low-cost imports that cannot yet compete in that regard. There is a move towards maintaining operations, design and manufacture within Europe. The principle being that doing so would allow manufacturers to have more control over the production line, product quality and respond faster to changes in market demand.



In light of these market developments, European manufacturing has responded through the re-engineering of the workforce, through innovation, as well as through the use of automation. Manufacturing companies in developed markets are capitalising on this through investment in automation solutions in order to remain competitive. This has been met with political backing countries like the U.S.A. where hopes are that it will help reduce (if not stop) the exodus of its manufacturing industries, and perhaps even help “re-shore” previously relocated manufacturing process back.¹¹ In this context, measurement technologies and robotics have an important potential to help provide automation solutions where they were previously unavailable.

The industrial robotics market was valued at EUR 6.49 billion in 2011, with an estimated growth of 5% per year¹². The robotics industry can be broken up between the following types of players:

- Robot designers and suppliers, such as ABB (Sweden);
- System integration specialists, such as M3 (UK) and Geku (UK);
- Suppliers of special components like actuators, controls or tools like laser welders;
- Suppliers of standard components like sensors, motors and standard electronics;
- Original Equipment Manufacturers (“OEMs”), such as Peak Robotics (USA);
- Software suppliers.

According to the International Federation of Robotics (“IFR”) the trend towards automation through robotics began in 2005 but was interrupted by the financial crisis in 2008-09. It however has restarted since 2010 (Figure 5). In 2011, sale of industrial robots increased by 38% to 1,575,000 units worldwide.

Figure 5: Estimated worldwide annual shipment of industrial robots

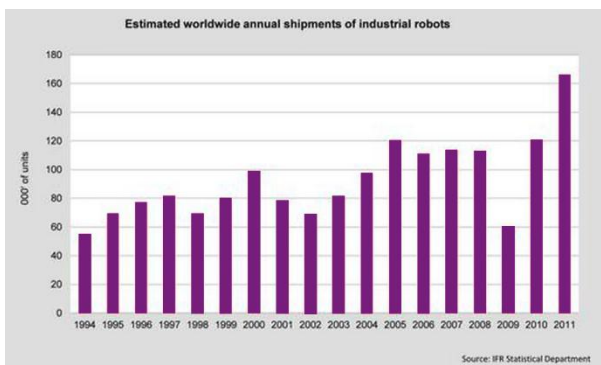

Source: IFR Statistical Department¹³

This, according to IFR, is the highest level ever recorded for one year. In Europe, 43,800 industrial robots were sold. This constituted around 43% more than in 2010. This increase was driven by a 66% increase in investment into robotics solutions in the European automotive industry compared to the year before. All other industries increased their investment towards robotics by 16%.

The best indicator of market size for measurement technologies linked to automation can be found in integrated measurement. The integrated-measurements market, which often caters high-tech markets, is estimated at around €500 million¹⁴ worldwide.

In addition, high-value markets where these advanced measurement solutions could be implemented include¹⁵: the medical devices market which was estimated at €229 billion in 2011 and growing, or the semi-conductor market which is a stable market that was estimated at around €28.3 billion in 2012.

In parallel, robotics can have applications in the automation of recycling of construction waste. The current volume of this market is estimated at around 11 billion tonnes a year globally, in which Europe accounts for 3 billion tons a year¹⁶. Conventional recycling is done manually and is very inefficient. It is also energy-demanding and has significant health risks. Automation could help improve recycling and thus reducing environmental impacts, as well as generates wealth through the re-use of high value materials.

3.2. Examples of novel successful measurement technologies and robotics solutions

In order to assess the latest developments in measurement technologies and robotics, eight innovative companies offering measurement technologies and robotics solutions were interviewed. Through desk research, these companies were identified as market leaders based on their demonstration of established success criteria; raising important amounts of capital and funds, creation of national or international partnerships; internationalisation; mention in the press and other awareness raising; securing of important business contracts; recipients of business and innovation awards.

The eight case companies shown in Table 3 offer novel innovative solutions to provide benefits towards manufacturing processes. Each of these companies has identified a market gap, and offers a novel measurement technology or robotics solution to address them.

**Table 3: Company case studies**

Company	Location	Business Innovation	Success Signals
Asyrl	Switzerland	Robotics for automation solutions	Winner of awards Several mentions in the press
Fluidion	France	Autonomous and simple water-measurement units	Several mentions in the press
Intermodalics	Belgium	Lightweight and flexible robotics solutions	Attended trade fairs Involvement in large research projects
Odico	Denmark	Superior polyester-cutting robot arms	Fund raising Several mentions in the press
Laytec	Germany	Integrated metrology solutions for industrial processes	Fund raising Several mentions in the press
Leosphere	France	Superior LIDAR technologies to measure atmospheric conditions	Published scientific papers Fund raising Several mentioned in the press
Winterthur Instruments	Switzerland	Paint coating measurement technology	Fund raising Several mentioned in the press Important industrial partners
ZenRobotics	Finland	Robotics solutions for construction waste recycling	Fund raising Wide distribution network Several mentions in the press

These companies have demonstrated their success signals because of the novel innovations they have provided to the market. Winterthur Instruments and Laytec are two companies that offer new measurement solutions that can be integrated within manufacturing processes. Fluidion and Leosphere are two companies that offer new more powerful measurement technologies than conventional ones. Odico and Asyrl offer new robotics technologies which allow for automation of manufacturing processes, increasing productivity as a result. Finally, Intermodalics and ZenRobotics provide robotics solutions to two different markets that previously could not benefit from automation.

Problem 1 – Verification of paint coating application at the industrial scale requires time to allow the paint to dry. If the paint is not properly applied, such as an incorrect thickness, the process needs to be repeated. A repeat in the process results in both production delays and increased costs.

Innovative solution 1: Integrated measurement of industrial paint-applications – Winterthur Instruments was founded in 2007 to commercialise the “CoatMaster ATO”, developed together with industrial partners J. Wagner, Sulzer Metco and AkzoNobel.

Customers can use the company’s instrument to measure coating thickness early in their process, even on parts coated with uncured powder coating or wet paint. These solutions allow the inspection of complex parts while they inspect different colours of paints in real-time, all without touching the material.

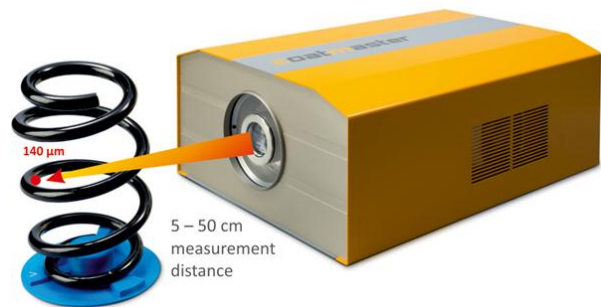
Winterthur Instruments CoatMaster

Source: Winterthur Instrument¹⁷

Problem 2 – Conventional measurement systems face two challenges in aqueous environments. Firstly the sampling of liquid for measurements generally involves flushing and then pumping away, which makes it liable to cross-contamination. Secondly, sampling operations that need energy require either large batteries or power cables, making them impractical for deep waters as well as for long durations.

Innovative solution 2: Cost-effective and long-lasting water measurement solutions – Fluidion is a French company founded in 2012 on patented passive micro-fluidic technology which allows several measurements. The solution is novel in that it only requires energy to transmit these measurements via telemetry.

The technology can be deployed at very low cost, providing a viable way for implementing wide-range monitoring campaigns. The solution allows significant miniaturization of samplers and fluid analyzers (h 23cm, D 16cm), at low cost and with unlimited electrical autonomy. The technology



allows measurement in extreme environments, where toxicity, radioactivity, temperature or pressure conditions render competing technologies vulnerable. All without the risk of false results through cross-contamination.

This solution has applications in industries that are regulated as to their impact on the local water environment by providing an automated and autonomous measurement solution.

Product specifications

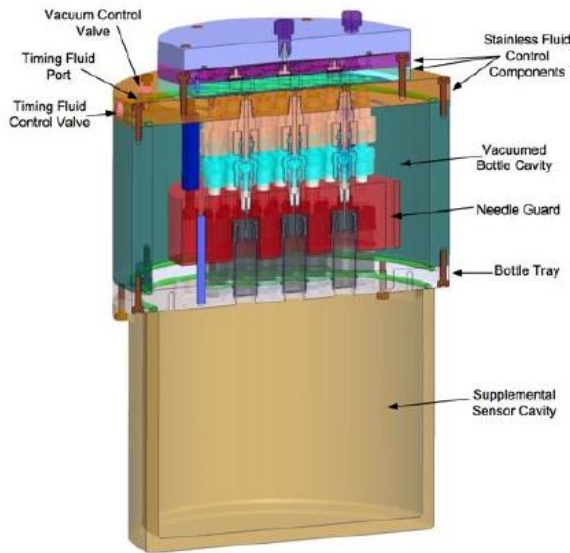

Source: Fluidion¹⁸

Problem 3 – Measurement of manufacturing processes through conventional measurement tools is time consuming and requires that production be halted whilst the measurement is made. In addition, they require skilled labour to operate and analyse the measurements, especially in high-tech industries where measurement is crucial to assure that products are of top quality.

Innovative solution 3: Integrated measurement solutions for process automation – Laytec is an established company, founded in 1999 in Berlin. The company provides integrated-measurement solutions to its clients in the semi-conductor and photovoltaic industry.

The company offers several highly accurate measurement solutions to be integrated into the production lines. This allows for continuous and automated measurements during production, saving time and therefore reducing costs. In addition, the company allows these measurements to be displayed so that measurement may indicate a result that does not conform to product specifications. It does so through an intuitive interface that can be understood and acted upon by un-skilled workers.

Laytec's Fault Detection and Classification (FDC) solution

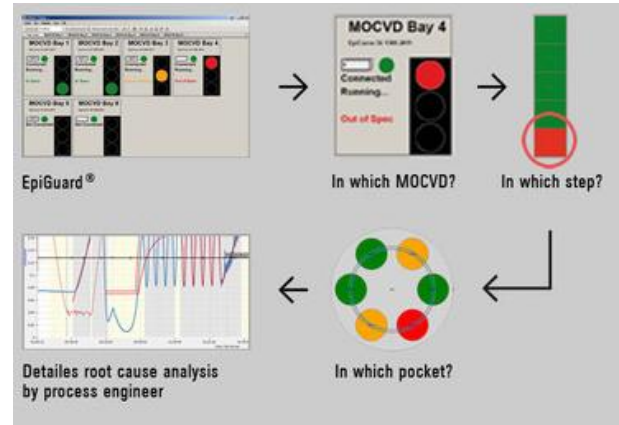

Source: Laytec¹⁹

Problem 4 – The need to better measure and quantify atmospheric conditions is becoming more imperative as wind farms become a more important source of renewable energy.

Innovative solution 4: Measurements for wind-power – Leosphere is a French company founded in 2004 that today employs 160 people. The firm has developed a range of LIDAR solutions dedicated to the measurement of atmospheric conditions. Their product offerings can allow on-shore and off-shore wind turbine site evaluations as well as in air-traffic management, climate and severe weather monitoring.

The company offers one of the most superior LIDAR technologies on the market. The LIDAR technology used can be set-up to monitor and measure wind strength and direction over time in wind-farm sites; in order to maximise efficiency of the energy generation. Additionally, the measurement technology can be integrated into individual wind turbines (through its subsidiary AVENT Lidar Technology). With this, wind farms could automate their orientation in order to optimally align themselves with oncoming wind, thus maximising energy generation.

Leosphere's WINDCUBEv2



Source: Leosphere²⁰



Problem 5 – The construction industry is one of the least automated industries and there is a growing demand for technology that can allow automation and produce non-standardised designs.

Innovative solution 5: Superior architectural robotics solutions – Odico is a Danish company founded in 2012 and based on a research partnership called “Project Blade-Runner”. The company has developed a novel robotics solution to automate the design of expanded polystyrene (EPS), materials which are used in construction.

The company offers a HotBlade technology that allows rapid automated design of EPS. In addition, the technology is capable of producing highly complex shapes. This robotics solution is 116 times faster than any other conventional method used for EPS design.

Odico robot arm with hot-wire cutter



Source: Odico²¹

Problem 6 – The traditional way to feed components to the assembly process is to use vibration bowls. As such, the production process is often inflexible and it requires laborious calibrations to change the type of component to be fed into the machine.

Innovative solution 6: Improving production process flexibility in the watch industry – Asyrl SA is a Swiss company founded in 2007. They focus on the development of flexible feeder systems and compact delta robots. They provide a novel alternative to traditional vibration bowl feeders which are used to feed components onto robotized machines.

The company has developed robotics solutions that provide fast and precise handling and assembly of small components. These can identify each separate component

and separate them accordingly, removing the need for several dedicated vibration bowls. This solution increases the reliability of production as it does not jam up in the same way that vibration bowls do.

Asyrl's PowerDelta robot



Source: Asyrl²²

Problem 7 – SMEs often have low production volumes and need to change production processes to suit their important short-term needs. As a result of these constraints, automation of production is not a viable solution for SMEs.

Innovative solution 7: Robotics for the SME market – Intermodalics is a start-up in the business incubator in Leuven that offers robotics solutions specifically to address the needs of SMEs in the plastics, steel and food & beverages industries.

The company offers lightweight robotics solutions that can easily be moved around across the manufacturing floor, from one station to another when production changes and does not have to be kept in a cage. In addition, the system can be “taught”: the user can easily interact with the robot in order to programme the robot’s next function. This is possible through a novel 3D vision developed by the company which offers superior measurement solutions for these robots.

Robotic arms: UR5 (left) LWR4+ (right)



Source: Intermodalics



Problem 8 – The waste management environment is far too complicated and chaotic for standard robot control systems. Controlling the robotic picking arm here demands incredibly deep knowledge of sensory fusion, data-mining, machine learning, and real-time robotics.

Innovative solution 8: Automating the recycling of construction waste – ZenRobotics is a Finnish company based in Helsinki that was founded in 2007 and offers the first robotics solution for waste management. To date, the company employs 40 members of staff.

The “ZenRobotics Recycler” uses multiple sensors (visible spectrum cameras, NIR, 3D laser scanners and haptic sensors) to create an accurate real-time analysis of the waste stream being currently processed. Based on the analysis, the system makes autonomous decisions on what objects to pick and how. Currently designed for construction and demolition waste (CND), ZenRobotics Recycler (ZRR) reclaims valuable raw materials from waste with the help of advanced machine learning technology. Currently the ZRR sorts metal, wood and stone fractions.

The Zen Robotics Recycler

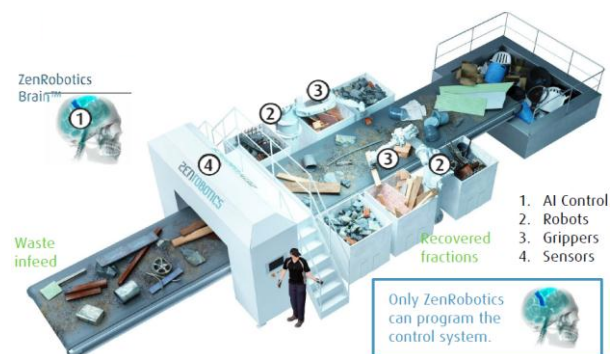

Source: ZenRobotics

3.3. Socio-economic impacts of measurement and robotics solutions

The use of more powerful measurement technologies or integrated measurement solutions helps increase the productivity of manufacturers. Winterthur Instruments and Laytec for example provide solutions which benefit their clients from understanding in real-time whether there is an error in their manufacturing process. Conventional solutions would not allow for this, meaning a large amount of wasted produce before the error is detected, resulting in large unnecessary costs. Early error detection also increases quality and client trust in turn.

Innovations in automation solutions allow these to be integrated as agents in increasingly symbiotic manufacturing systems, empowering the workers, serving them to be more

productive. Intermodalics robotics solutions, empowers their customers with robots that can easily be moved around the production line without the need for safety cages. In addition, their solutions allow easy re-programming of the robot's function without the need for IT skills. Such innovative automation solutions is at the core of human-centred automation and allows applications throughout the manufacturing industry to perform tasks other than traditional assembly-line work, such as warehouse logistics or in the construction industry. Odico's robotics solution for example, permits automation in the construction industry, increasing output of expanded polystyrene by up to 116 times more than conventional production methods.²³

This use of automation in novel ways impacts all areas of production, providing more flexible approaches to manufacturing and assembly and bringing to these industries the benefits of increased productivity and quality, enhanced health and safety. It also helps improve the environmental impact of manufacturing as energy consumption is reduced through improved energy efficiency. Moreover, the use of automation solutions in logistics helps increase the efficiency of loading and unloading of pallets, allowing the task to be done in a shorter amount of time.

Food safety in the food and beverage industries is an important concern. That is why the risk of contamination of the foodstuffs is taken with great attention, especially when considering manufacturing processes. Following that, reducing the need for workers to come into contact with the product is an asset. This can be done with the use of robots. Another example of such an application is ensuring the quality through the use of integrated measurement technologies. Automation solutions in this industry minimises chances of contaminated produce, benefitting the customer, and minimising liability for the manufacturer.

Communities closely linked with large factories have often feared the use of automation solutions (robots in particular) with the loss of jobs as workers were replaced by these. In fact, the opposite is true as manufacturing businesses have the potential to save and create more jobs than they eliminate.²⁴

Finally, more powerful measurement solutions like the ones offered by Fluidion and Leosphere for instance can provide companies better adherence to standards and regulations. The measurement technology proposed by Fluidions allows any company that has an impact on the nearby water ecosystem to measure precisely if any contaminants enter its water-systems.

Clients consequently benefit from the ability to do so in a cost-effective manner, with minimal energy requirements, and with the ability to keep their measurement solutions in place over long periods of time. In another sector, Leosphere provides cutting-edge measurement solutions for air-conditions. For instance, it provides accurate data as to the



potential of wind farm sites. When integrated with existing wind farms, its technology helps optimise the energy productivity of wind turbines as they can autonomously align themselves to oncoming wind.

3.4. Market adoption

The external factor driving the technological developments in this trend is the need for European manufacturing to gain a competitive advantage on the global market. As the emerging markets further increase their own automation within manufacturing, it becomes important for European manufacturers to innovate in their production processes so as to remain competitive.

Since automotive is by far its most important client, the future outlook of automation in Europe – and consequently of measurement technologies and robotics – will heavily depend on the recovery of its automotive industry. With the current economic crisis having impacted on the industry, it has been forced to restructure itself.

Another driver for automation solutions are the increasing demands on businesses to reduce their environmental impacts because of regulations. Robots and new measurement tools and applications have a role to play as manufacturing processes are developed to be made cleaner and more energy-efficient. In addition, the use of automation can help drive environmental industries, such as the photovoltaic manufacturing industry, where the EU is losing its place as the world leader.²⁵

The globalisation of the robotics industry is also helping drive this trend. The early markets for robotics were in OECD nations, with countries like Japan, Korea, the USA and Germany, accounting for the majority of the market then. Today, robotics solutions have been implemented in countries like China, when automotive industries, like Hyundai, relocated their production there. In addition, the producers of these automation solutions can now be found in parts of Latin America and Asia. Following this, the market of robotics is increasingly globalised, which forces European companies to improve their technologies and keep innovating.

The increasing importance of e-commerce is also placing pressures on manufacturers to automate their production processes.²⁶ Today, distribution is either very cheap, or free, and businesses must offer advantageous supply offers to be competitive. Companies are faced with having to increase the number of their stock keeping units, even if they are not necessarily increasing their production. This forces a change in traditional supply-chain management through automation solutions like warehouse robotics.

An obstacle to the uptake of the trend is down to the remaining limitations of the technological solutions that still need to be progressively overcome. This will depend on the

industrialisation of novel and innovative measurement technologies and robotics. Metrology and robotics are diverse fields and technological progress in the past has been observed as a gradual build-up in small and diverse fields. Examples of the technical impacts required for the continued development and uptake of industrial robotics is shown in Figure 6. For example, developments in cognition through the development of new algorithms could help a robot arm distinguish one product from another, by vision solutions. The ability to differentiate between different objects would make the robotics solution even more flexible. Progress in these fields would help make robotics more attractive with regards to utility against costs.

Figure 6: Technical advances required for industrial robotics

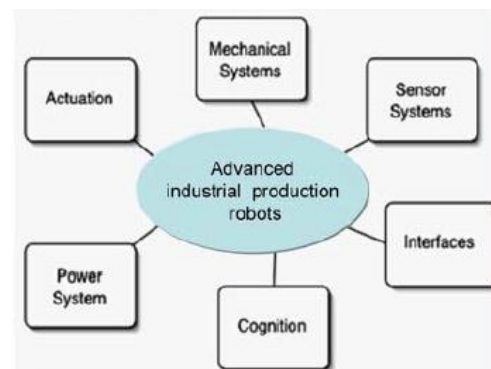

Source: Forge and Blackman (2010)

Another important obstacle to be considered is the ethical implications and public acceptance of the uptake of measurement technologies and robotics. Whilst automation promises to improve the competitiveness of manufacturers, the latter may consider they do not need to reallocate existing resources and so dismiss workers. This substitution of human workers through the mechanisation raises ethical concerns, even if, robotics and measurements technologies have a positive impact on employment, as explained in the previous section. The creative destruction resulting from the uptake of such technologies implies public measures to reduce its downsides and helped unskilled workers to develop and be reallocated to more skilled jobs.

3.5. Uptake of automation solutions by SMEs in the manufacturing sector

An important factor to consider as to the development of the trend is its uptake by SMEs. SMEs contrast with typical industry convention in that they do not present a market for industrial robots. Robots are normally aimed at large-scale industrial applications and for continuous working of high production volumes. SMEs account for 92% of all employment in the EU, and 68.2% of all jobs in manufacturing.²⁷ These, though, have not widely adopted measurement technologies and robotics, nor they have they ever been encouraged to do so.



The reason why these automation solutions have not been widely taken up by SMEs as these solutions were often capital-intensive and best suited for large-volume production. These companies were often faced with a decision; either opt for current automation solutions that were inappropriate for their need for low-volume and low-costs. Or employ workers to perform the manufacturing process manually, and compete on the basis of lower wages. New and innovative measurement technologies and robotics solutions must ensure that they propose ways to tackle the obstacles that would normally inhibit the uptake of the solutions:

- Low capitalisation and difficult access to finance for SMEs in the current economic climate;
- Lack of awareness of the benefits of robotics and measurement technology solutions;

- Low technical competence outside core business. This is especially important given that these automation solutions require technological competences;
- Low capability of SMEs for long term investment.

The implementation of robotics solutions in SMEs was surveyed in 2008 within the scope of the SME robot project (Figure 7). The latest developments in robotics have looked to address these factors that would otherwise inhibit uptake. For example, there has been a steady decline in the cost of measurement technologies and robotics⁶. This is an important development as pricing plays an important role in the uptake of automation solutions by SMEs. In addition, some financial incentives exist in order to increase their attractiveness, such as the refurbishment of robots or measurement tools, or leasing arrangements.

Figure 7: Why SMEs don't use robots

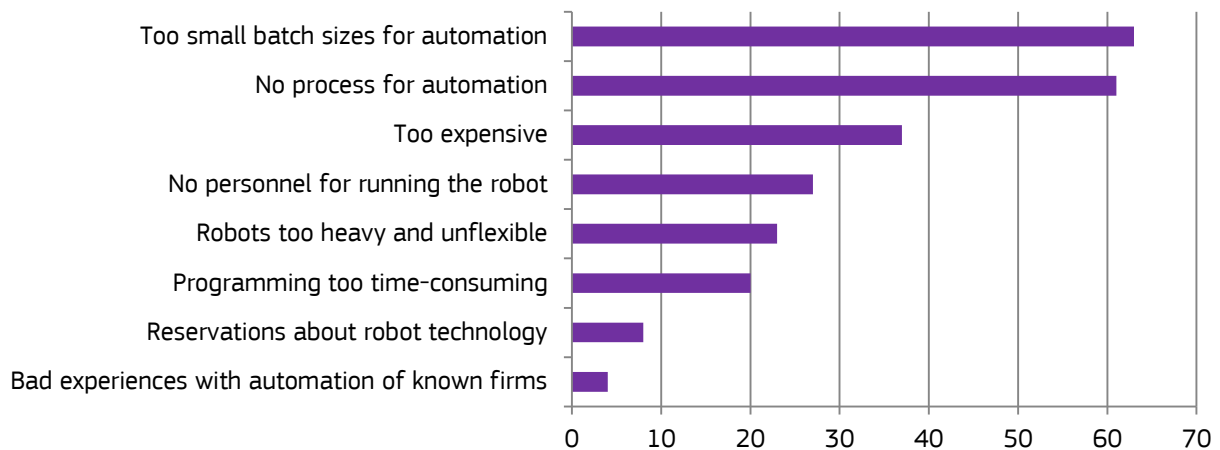

Source: Final report of the SME robot project, PwC

*“The food and beverage sector lacks skills, resources and know-how on optimal robot use generally, especially when compared with the car industry”.*⁶

Should pricing and flexibility needs be met, the possibility exists for much a wider implementation of measurement technologies and robotics in many SMEs. The fastest growing sectors for SMEs are in the food and beverages, and in high-tech industries like photovoltaic panel assembly.

Today, there is an important development in the field of robotics where suppliers are providing solutions that meet the needs of SMEs. This is exemplified by Intermodalics, which developed an all-encompassing robotics solution. This

solution offers financially attractive lightweight robots that can be easily moved from one process station to another depending on the needs of the customer. It also can be safely operated in proximity of human workers without them needed to be caged. In addition, it proposes solutions to the need for reprogramming the robot every time its function requires to be changed. This is done through the company's 3D vision solution, which allows the robot to be physically shown how to perform a task by a user, and then repeats it autonomously. This makes the robotics solution user-friendly for workers that have no technical knowledge of robots or machine learning.



4. Drivers and obstacles

4.1. Proof of concept improves access to finance

The uptake of the trend relies on the success of start-ups bringing new developments and innovation to market. As with start-ups and SMEs in other industries, the interviewed companies indicated that access to finance was one of the more demanding issues in their development. However, the majority of the interviewees stated that whilst the task of obtaining funding was time-consuming, they did not consider it a difficult task. For example, companies like Odico benefitted from attracting the interest of several investors, which allowed them to go with the support of a business angel who was personally invested in the project.

All of the measurement technology and robotics solutions offered by the interviewed companies had been developed beforehand within a research or academic context, and if not the solution then an important component of it. One of the benefits of these automation solutions is that their proof of concept can be demonstrated more easily than other technologies. For instance, a measuring tool or application, or a new robotics system does not have to be scaled up in the same manner as other technological developments brought to market. A biofuel synthesis solution, for example, would be demonstrated first in laboratory conditions, but then would have to be scaled up with the construction of a pilot-plant facility to demonstrate the industrial capacity of the technology. This is this scaling-up phase and the conduction of pilot testing that are more particularly challenging for companies developing measurement and robotics solutions. This is consequently where public support should focus so as to propose a coherent and consistent framework for SMEs' development.

Moreover, the ease with which proof of concept is achieved is a determining factor in the ease with which financing is obtained. Generally, the stage from development of a technology to its industrialisation is the most difficult. This is because demonstrating proof of concept is often capital intensive, and funding will often not have been secured by that stage. With proof of concept, provided the technology is believed to have merit, obtaining funding is more straightforward. Public intervention may also be meaningful to facilitate interactions between innovative companies and investors to incentivise risk funding and so reduce the financing gap.

4.2. Industrial partnerships help get a foothold into the market

The interviewed companies indicated that the strategy for market entry is of critical importance. All companies had developed technologies that may be used in a variety of sectors (Table 4) however they deliberately chose to concentrate on entering the market by targeting a single application. These choices resulted from detailed market analysis and the identification of potential niches. They also applied a "think big, start small" approach, enabling the start-ups to secure their initial markets before transferring best practices in other sectors.

Table 4: Industrial partnerships help get a foothold into the market

Company	Industries where automation system could be applied
Asyrl	Watch-making Medical Semi-conductors
Fluidion	Water-management Oil exploration Risk-management in nuclear energy
Intermodalics	Food and beverage Packaging Steel and metal
Laytec	LED Photovoltaics Semi-conductors
Leosphere	Wind-farms Airport traffic Airspace management
Odico	Construction Architecture Cement producers
Winterthur Instruments	Automotive industry Any industry where paint needs to be applied to product autonomously
ZenRobotics	Food & beverage Mining Micro-assembly Waste recycling Dock loading Warehouse logistics



“We are a small company and so are focusing on the automotive market, despite the innovation being widely applicable. Wherever coatings are being applied, the company has a market.”

– Winterthur Instruments

For example, Winterthur Instruments have developed a measurement technology that can be applied to measure the application of paint on any product in a manufacturing process. This may be applied in a wide variety of manufacturing processes, whether it be in kettles, bikes or in car

manufacturing. The company, however, recognised their small size, and so strategically entered the market offering their solution to car parts suppliers. The purpose being to generate a comfortable amount of revenue before developing the company further, thus minimising their risk.

The choice of a strong partner is also an important consideration. This is because the number of business partners may be quite limited for these technological options after the start-up has brought its technology to market. Winterthur Instruments deliberately partnered with AkzoNobel, which is a large supplier of automotive parts. In a different sector, ZenRobotics which is a fully independent company benefitted from supplying SITA Finland as their pilot customer. Importantly, SITA Finland is a subsidiary of SITA Suez, which is one of the largest environmental companies in the world.

4.3. A local knowledge and culture conducive to development of these technologies

An important criterion for the development of successful firms offering analytics and decision-making solutions is the regional knowledge infrastructure. This includes the presence of higher education and research institutions in fields specific to the industry, technology transfer organisations, shared technology platforms, as well as sector specific courses or training in the region.

Research into measurement technologies and robotics is well established in Europe, through EU schemes like the European Robotics Research Network (EURON)²⁸ or the European Robotics Technology Platform²⁹ for robotics, and different national academic R&D schemes. Through this, several clusters of excellence in the field of robotics and metrology have emerged in Europe.

All interviewed companies benefitted from the presence of the centres of excellence established in their relative fields, or from the background of their key employees in technological backgrounds at nearby universities or research centres (Table 5). Furthermore, some interviewed companies had founding members that were employed at research centres or higher education institutions. In the case of other companies, these were direct spin-offs commercialising on their research.

Table 5: Links with research or higher education institutions

Company	Country	Links with research or higher education institutions
Asyrl	Switzerland	Centre Suisse d'Electronique et de Microtechnique
Fluidion	France	Université Paris-Est/ESIEE Paris
Intermodalics	Belgium	Katholieke Universiteit Leuven
Laytec	Germany	Technical University Berlin Fraunhofer Institute Metrology institute in Berlin
Leosphere	France	Centre Nationale Recherche Scientifique Links with several local universities
Odico	Denmark	Technical University of Denmark
Winterthur Instruments	Switzerland	Zurich University of Applied Sciences
ZenRobotics	Finland	Aalto University Links with other local academia.

The presence of nearby centres of excellence and universities in relevant technologies also benefits the companies as they develop and take on new employees. Odico for example is comprised of architects and engineers. The company benefits from a combination of expertise within the fields of architectural robot production, programming, design development, computer-aided workflows and geometry optimisation. These skills can be found nearby, as the company's location in Odense is close to a Danish centre for excellence in robotics. ZenRobotics benefits from the presence of many graduates in Helsinki having skills in machine learning, artificial intelligence and robotics necessary to their business.

4.4. Support schemes supporting innovative start-ups

The companies interviewed benefitted from a range of support measures including business incubation services, government subsidies, tax credits for private investors and R&D activities as well as research grants. The technologies were developed within a research or academic context through public funding, national or EU funding, and in some cases the funding was from a public-private partnership. This was the case for Winterthur Instruments which developed its measurement technology through a combination of funding from public and private partners. In this scheme the public sector would match investment that came from private partners.



Of particular interest is the support provided to innovative SMEs in Switzerland. For instance, Asyrl and Winterthur Instruments benefitted from support from the Swiss Commission for Technology and Innovation (CTI). The CTI is the Swiss Federal Agency responsible for encouraging scientific innovation in Switzerland, and offers different support programmes. Winterthur Instruments benefitted from one of these ; the “Start-Up and Entrepreneurship” programme. This programme provides assistance to start-ups through part-time experts and coaches. The programme encourages companies to pitch their ideas to a panel of experts and entrepreneurs and, if successful, these are provided with help in business plan development, legal assistance for intellectual property matters and coaching in business administration.

Asyrl benefitted from the “R&D Funding” programme. In this programme, the CTI funds joint research and development projects involving companies, public authorities, non-profit organisations and higher education institutions. A similar public support scheme exists in Finland where there is a publicly funded expert organisation for financing national research, development and innovation. This organisation is called Tekes and benefits innovative start-ups in Finland in a

similar way as the Swiss CTI scheme. ZenRobotics stated that such a scheme was useful in helping them find sources of investment. The company also stated that a Finnish governmental organisation called Finnvera, had an important role, having co-invested in the company as well as assisting ZenRobotics with finding investors.

These public support schemes are crucial in helping drive research in measurement technologies and robotics, as well as helping companies bring them to market successfully. However, an obstacle for many of the companies is the administrative burden in order to obtain public support. The reporting for this public support in some companies takes up around 70% of the time of one employee. For small start-ups with few employees, this would result in the allocation of a significant amount of resources for what they believe is insignificant gain. For instance, companies like Odico and Laytec did not apply for public funding because they felt the costs outweighed the benefits.

“Its too much bureaucracy, its too much paperwork, its too much of a process, and there’s less freedom to act. [...] That was one of the things we got rid of when we went with private investment” – Odico

5. Policy recommendations

This section elaborates on the three areas which policy could target have been highlighted for further investigation, namely: promotion of R&D in measurement technologies and robotics, awareness-raising as to the benefits of automation and support of start-ups bringing these technological innovations to market.

5.1. Promoting R&D in measurement technologies and robotics

All of the interviewed companies during this study brought knowledge, expertise and technological innovations built up from past research activities to the market. This highlights an important aspect of this trend in business innovation; that the most fundamental way of promoting technological developments in robotics and measurement technologies, is to promote fundamental and applied research in these fields. The logic being that the more backing research and development these fields of study benefit from, the more likely new technological improvements or even breakthroughs could arise.

Research and development in measuring technologies and robotics is in a strong position in Europe, with good levels of funding through multiple national and EU-wide initiatives. This has resulted in the development of multiple regions across the continent where there is a critical mass of

universities, research centres, industries and a skilled workforce in these technological fields. In addition, the fact that research and development in this area is in a good position has a lot to do with the involvement of private sector funding and partnerships.

Greater attention could consequently be paid to the opportunities to promote R&D efforts in automation solutions addressing the needs of SMEs. In other words, the integration of automation solutions into business projects leading to a market value proposition. In that perspective, funding or financial incentives could be targeted specifically at research into opportunities to create more cost-effective and flexible solutions.

Research funding could for instance be specifically targeted at mechanicals, materials, and software for human-robot interaction. In addition, the following areas could be of special interest for developing business solutions: natural language processing and cognition, robot operating systems, signal processing, vision systems, simulation packages and communications. Flexible automation solutions for un-skilled users also need to be developed, with new user-friendly interfaces and intuitive human-machine interfaces.

The scientific problems in overcoming these technological limitations are unlikely to be addressed in a single country. Therefore a continued close collaboration between the



European research groups through initiatives like EURON is needed in order to provide adequate resources, while ensuring a breakthrough in new automation solutions. Through such integrated EU initiatives, European industries could stay on the continent while proposing innovative solutions for currently unmet needs, such as solutions specifically tailored to SMEs.

5.2. Raising awareness of the benefits of automation

“European automation is a shrinking market. The question is whether we are in time to help stop, and even reverse, that with our robotics solutions” – Intermodalics

Automation is a viable solution for the EU manufacturing sector looking to gain competitive advantages within the global competition. Increasing awareness as to the benefits of automation in terms of production improvement, energy savings and improved product quality could help drive market. The reasons why manufacturers may have not fully embraced automation solutions using measurement technologies or robotics, is often down to a lack of knowledge about their benefits, a hesitation because of the ethical implications of automation, as well as a reluctance to invest large amounts of capital. The support of demonstrator projects could encourage new end-users to see what can be done with automation. Initiatives like the PPP for Factories of the Future are good examples of how this can be done.

Promoting education specific to robotics and measurement technologies through courses is another solution as a long-term strategy. These areas often require a combination of skills such as engineering, mathematics, science and IT. Courses and professional trainings in these fields would require student / trainee support, the definition of specific

curricula and mix of programmes, work placements and apprenticeships as well as industrial postgraduate research opportunities and access to the research centres of excellence distributed across the EU.

5.3. Improving support of start-ups

There is a gap across the EU regarding available support schemes for start-ups. Some of the interviewed start-ups felt that it is a hindrance to request public support. For instance, it is almost unfeasible for a start-up, with very few employees, to have to devote large amounts of time to application proceedings and reporting. The primary factor to address would be the administrative burden faced by beneficiaries of public aid. Reducing this and helping SMEs in their start-up phase through simpler administrative applications for grants or mentorship programmes would consequently be of great help. An avenue to be investigated would be the selectivity towards applications from start-ups bringing measurement or robotics solutions to market, using a panel of experts and entrepreneurs. Ideas with potential would be accepted and administrative reporting reduced once the applicant has passed the initial evaluation.

The public support schemes such as the Swiss CTI, and the Finnish TEKES are good examples of public support solutions that meet the needs of start-ups. Emulating these across the EU either via regional, national or international schemes could help promote the development of start-ups and assist companies bridge the “valley of death”³⁰ when bringing a technology to market. Furthermore, opportunities to network with industrial or business partners is an invaluable benefit to founders of innovative companies that often have advanced technical skills but limited business know-how.



6. Appendix

6.1. Interviews

Company	Name	Designation
Asyrl	Alain Codourey	CEO
Fluidion	Dan Angelescu	President
Intermodalics	Peter Soetens	CEO
Laytec	Thomas Zettler	CEO
Leosphere	Eric-Jean Pankowski	Finances & Organisation
Odico	Anders Petersen	CEO
	Jelle Feringa	CTO
	Asbjorn Sondergaard	CDO
	Lars Baun	Chairman of the board
Winterthur Instruments	Andor Bariska	CEO
ZenRobotics	Jufo Peltomaa	VP of Marketing

6.2. Websites

Asyrl	www.asyrl.ch
Fluidion	www.fluidion.com
Intermodalics	www.intermodalics.com
Laytec	www.laytec.com
Leosphere	www.leosphere.com
Odico	www.formworks.dk
Winterthur Instruments	www.winterthurinstruments.com
ZenRobotics	www.zenrobotics.com

6.3. References

- ¹ Kalpakjan, Schmid. (2008). Manufacturing Processes for Engineering Materials. 5th ed.
- ² Swann, P.G.M. (2009). The Economics of Metrology and Measurement. Report for the National Measurement Office. Department for Business, Innovation and Skills. Final Draft.
- ³ Optical measuring technologies. (2013) Available from: <http://www.gom.com/industries/sheet-metal-forming/automated-quality-control.html>
- ⁴ The future of manufacturing in Europe 2015-2020, Factory of the Future roadmap 2010, HLG report on AMT
- ⁵ International Federation of Robotics definition of an industrial robot. Available from: <http://www.ifr.org/industrial-robots/>
- ⁶ Forge, S. and Blackman, C. (2010). A Helping Hand for Europe; the competitive outlook for the EU robotics industry. JRC: Institute for Prospective Technological Studies.
- ⁷ International Federation of Robotics statistics. Available from: <http://www.ifr.org/industrial-robots/statistics/>
- ⁸ Eurostat. (2013). online data code: sbs_na_ind_r2. Available from: http://epp.eurostat.ec.europa.eu/statistics_explained/index.php/Manufacturing_statistics_-_NACE_Rev_2
- ⁹ Credit Suisse Global Equity Research. (2012). Global Industrial Automation. 14 August.
- ¹⁰ PwC analysis



- 11 The Economist. (2013). Coming home. Jan 19th 2013.
- 12 Communication from Asyriil CEO
- 13 <http://www.ifr.org/industrial-robots/statistics/>
- 14 Communication from Laytec CEO
- 15 Communication from Asyriil CEO
- 16 ZenRobotics presentation
- 17 Winterthur Instruments website. <http://www.winterthurinstruments.com/en/inspection-advantages.html>
- 18 Fluidion presentation
- 19 Laytec website. <http://www.laytec.de/key-technologies/advanced-process-control/fault-detection/?L=1602khpjcntmqhbb>
- 20 Leosphere website. <http://www.leosphere.com/8.windpower/34.key-benefits>
- 21 Odico presentation
- 22 Asyriil website. <http://www.asyriil.ch/en/products/delta-robots.html>
- 23 Communication from Odico's CEO, CTO, CDO and Chairman of the board.
- 24 Business Week. Robots can create jobs too. (2010) Available from: <http://www.businessweek.com/stories/2010-06-02/robots-can-create-jobs-too>businessweek-business-news-stock-market-and-financial-advice
- 25 European Photovoltaic Industry Association. (2013). Global Market Outlook for Photovoltaics 2013-2017. http://www.epia.org/index.php?eID=tx_nawsecuredl&u=0&file=/uploads/tx_epiapublications/GMO_2013_-_Final_PDF_01.pdf&t=1372155673&hash=552d1b4b98dbd96d7b30c032eb2cd7585942fa1d
- 26 Modern Materials Handling. (2012). Available from: http://www.mmh.com/article/automation_four_trends_driving_automation
- 27 Annual Report on European SMEs 2012/2013. (2013). Closing the gap between policy makers & market dimensions. [Document to be published soon]
- 28 European Robotics Research Network. <http://www.euron.org/>
- 29 European Robotics Technology Platform. <http://www.robotics-platform.eu/cms/index.php?idcatart=119&client=1&lang=1>
- 30 Forbes. 10 ways for startups to survive the valley of death. (2013) Available at : <http://www.forbes.com/sites/martinzwilling/2013/02/18/10-ways-for-startups-to-survive-the-valley-of-death/>