



EUROPEAN COMMISSION
DIRECTORATE-GENERAL FOR ENERGY
The Director

Luxembourg, 01/06/2012

INVITATION TO TENDER No. ENER/D4/2012-104-3

(open procedure)

Dear Sir/Madam,

1. The European Commission invites tenders for a supply contract regarding the following project:

"Deposit Boxes Arrangement, Schliessfachanlage, Armoire à casiers"

This invitation to tender follows the publication of:

- the contract notice in OJEU 2012/S 103-171322 of 01/06/2012

2. If you are interested in this contract, you must submit a tender in **triplicate**, in one of the official languages of the European Union. A copy of the offer on a CD/DVD has also to be submitted.

Tenderers may choose to submit tenders:

a) either by post or by courier not later than 13/07/2012, in which case the evidence of the date of dispatch shall be constituted by the postmark or the date of the deposit slip, to the following address:

European Commission
Directorate-General for Energy
For the attention of **Mr Klaus Schnuer** EUFO 4455
Jean Monnet Building
Plateau de Kirchberg,
L-2920 Luxembourg

(b) or delivered by hand to the following address:

European Commission
Directorate-General for Energy
For the attention of **Mr Klaus Schnuer** EUFO 4455
Jean Monnet Building – main entrance
Rue Albert Wehrer,
Plateau de Kirchberg,
L-2920 Luxembourg

not later than 16.00 on 13/07/2012. In this case, a receipt must be obtained as proof of submission, signed and dated by the official in the Commission's central mail department who took delivery. The department is open from 08.30 to 17.30 Monday to Thursday, and from 08.30 to 16.30 on Fridays. It is closed on Saturdays, Sundays and Commission holidays.

3. Tenders must be placed inside two sealed envelopes, one inside the other. **The inner envelope should be marked:**

<p>Call for tenders No. ENER/D4/2012-104-3 <u>not to be opened by the internal mail department</u> EUFO 4455</p>
--

If self-adhesive envelopes are used, they must be sealed with adhesive tape and the sender must sign across this tape.

The non-compliance with these formal conditions may entail the rejection of the bids at the opening session.

To be admissible, the confidentiality of the bids must have been ensured and the deadline for the submission of the bids met.

4. Tenders will be opened at 10 a.m. on 20/07/2012 at:

Directorate-General for Energy
EUROFORUM building 4198
1, rue Henri Schnadt
L-2530 Luxembourg

This opening session will be public. Each tenderer may be represented by not more than one person. At the end of the opening session, the Chairman of the opening committee will indicate the name of the tenderers and the decision concerning the admissibility of each offer received. The prices mentioned in the bids will not be communicated.

5. The specification, listing all the documents that must be produced in order to tender, including supporting evidence of economic, financial, technical and professional capacity and the draft contract are attached.
6. All tender documents shall be perfectly legible so that there can be no doubt as to words and figures.
7. Validity period of the tender: six months as from the final date for submission of tenders mentioned under point 2 above.
8. Submission of a tender implies acceptance of all the terms and conditions set out in this invitation to tender, in the specification, in the draft contract and, where applicable, waiver of the tenderer's own general or specific terms and conditions. The terms and conditions are binding on the tenderer to whom the contract is awarded during the performance of the contract.

9. Contacts between the awarding authority and tenderers are prohibited throughout the procedure except in exceptional circumstances and under the following conditions only:

Before the closing date for submission of tenders

- At the request of the tenderer, the awarding authority may provide additional information solely for the purpose of clarifying the nature of the contract.

Any requests for additional information must be sent in writing to the following address:

Mrs Kersti Peedo
European Commission
EUFO building 4456
L-2920 Luxembourg
Fax (+ 352) 43 01 36280
e-mail: kersti.peedo@ec.europa.eu

Requests for additional information received less than five working days before the closing date for submission of tenders will not be processed.

- The Commission may, on its own initiative, inform interested parties of any error, inaccuracy, omission or any other material shortcoming in the text of the tender documents.

All additional information will be made available via Directorate-General for Energy website (DG ENER). Tenderers are invited to consult this site regularly until the deadline for submission.

After the opening of tenders

If a tender requires clarification, or if there is a need to correct material errors which have occurred in the drafting of the tender, the Commission may take the initiative and contact the tenderer(s). Such contact shall not lead to the conditions of the tender being altered in any way.

10. This invitation to tender is in no way binding on the Commission. A commitment will come about only when a contract with the successful tenderer has been signed.

Until a contract is signed, the awarding authority may decide not to award a contract or to cancel the tendering procedure, without the candidates or tenderers being entitled to claim any compensation. Where appropriate, the decision will be substantiated and brought to the attention of the tenderers.

11. Tenderers will be informed of whether their tenders have been accepted or rejected.

12. If your offer includes subcontracting, it is recommended that contractual arrangements with subcontractors include mediation as a method of dispute resolution.

13. If processing your reply to the invitation to tender involves the recording and processing of personal data (such as your name, address and CV), such data will be processed pursuant to Regulation (EC) No 45/2001 on the protection of individuals with regard to the processing of personal data by the Community institutions and bodies and on the free movement of such data. Unless indicated otherwise, your replies to the questions and any personal data requested are required to evaluate your tender in accordance with the specifications of the invitation to tender and will be processed solely for that purpose by the Director of the Shared Resource

Directorate MOVE/ENER, acting as data controller. Details concerning the processing of your personal data are available on the privacy statement at: http://ec.europa.eu/dataprotectionofficer/privacystatement_publicprocurement_en.pdf.

14. Your personal data (name, given name if natural person, address, legal form, registration number and name and given name of the persons with powers of representation, decision-making or control, if legal person) may be registered in the Early Warning System (EWS) only or both in the EWS and Central Exclusion Database (CED) by the Accounting Officer of the Commission, should you be in one of the situations mentioned in:

- the Commission Decision 2008/969 of 16.12.2008 on the Early Warning System (for more information see the Privacy Statement on http://ec.europa.eu/budget/info_contract/legal_entities_en.htm), or

- the Commission Regulation 2008/1302 of 17.12.2008 on the Central Exclusion Database (for more information see the Privacy Statement on http://ec.europa.eu/budget/library/explained/management/protecting/privacy_statement_ced_en.pdf)

Yours faithfully,

Peter Faross
Director

TENDER SPECIFICATIONS
ATTACHED TO THE INVITATION TO TENDER

Invitation to tender No ENER/D4/2012-104-3 concerning
"Deposit Boxes Arrangement, Schliessfachanlage, Armoire à casiers"

TABLE OF CONTENTS

I	SPECIFICATIONS
I.1	INTRODUCTION
I.2	PURPOSE OF THE CONTRACT
I.3	TIMETABLE TO OBSERVE
I.3.1	DESIGN OF THE INSTALLATION
I.3.2	SETTING UP OF THE INSTALLATION
I.3.3	REPAIR SERVICES
I.4	DURATION OF THE TASKS
I.5	PLACE OF PERFORMANCE
I.6	ESTIMATE OF THE AMOUNT OF WORK INVOLVED
II	TERMS OF CONTRACT
II.1	TERMS OF PAYMENT
II.2	SUBCONTRACTING
II.3	JOINT TENDER
III	FORM AND CONTENT OF THE TENDER
III.1	GENERAL
III.2	STRUCTURE OF THE TENDER
III.2.1	<i>FIRST SECTION: ADMINISTRATIVE PROPOSAL</i>
III.2.2	<i>SECOND SECTION: TECHNICAL PROPOSAL</i>
III.2.3	<i>THIRD SECTION: FINANCIAL PROPOSAL</i>
IV	ASSESSMENT AND AWARD OF THE CONTRACT
IV.1	EXCLUSION CRITERIA - EXCLUSION OF TENDERERS
IV.1.1	<i>EXCLUSION CRITERIA (ART. 93 OF FINANCIAL REGULATION)</i>
IV.1.2	<i>OTHER CASES OF EXCLUSION</i>
IV.1.3	<i>EVIDENCE TO BE PROVIDED BY THE TENDERERS</i>
IV.1.4	<i>ADMINISTRATIVE AND FINANCIAL PENALTIES</i>
IV.2	SELECTION CRITERIA – SELECTION OF TENDERERS
IV.2.1	<i>ECONOMICAL AND FINANCIAL CAPACITY – REFERENCES REQUIRED</i>
IV.2.2	<i>TECHNICAL AND PROFESSIONAL CAPACITY – REFERENCES REQUIRED</i>
IV.3	EVALUATION OF TENDERS - AWARD CRITERIA
IV.4	INFORMATION FOR TENDERERS
V	ANNEXES

I. SPECIFICATIONS

I.1. Introduction

Specialised European Commission staff members need for accomplishment of their duties personal documents and equipment. Due to personal data and physical protection reasons these items need to be safely locked and only accessible by the individual staff member. Therefore, the Directorate General for Energy, in particular the service responsible for health protection would like to acquire and install inside the Commission office building, EUROFORUM, in the Cloche d'Or area in Gasperich, Luxembourg, a deposit boxes arrangement. This installation should be similar to those for distribution and deposit of letters in post offices or in banks.

I.2. Purpose of the contract

The European Commission Directorate General for Energy would like to purchase arrangements consisting in total of about 240 individual letterbox type small lockers. Each locker shall be individually locked and be opened by an individual key or by an electronic system. An advantage would be to have an access to a larger number of individual lockers at the time, i.e. a possibility to open a group of locker doors together in one action. It shall be possible to open this door frame to the front because the whole locker arrangement will stand against the wall.

The items to be stored in each of the small lockers are one standard EU passport size document and two items of about a mobile phone or cigarette box size.

- The inside dimension of each locker shall be in the order of 25-31 cm wide, 25-45 cm deep and between 5 and 8 cm high.

Drawing 1 (see below) visualises a draft design of the lockers arrangement with outside dimensions and dimensions of an individual box.

- Each locker shall be individually closed and locked. The opening may be done by an individual key or electronically from a central control unit by introducing an individual code number or by using an electronic identity card. (There is an electronic identity card reader system installed inside Commission buildings. The technical details and the manufacturer of the system can be communicated during the performance of this open procedure.)
- Each locker door shall show an engraved running number.
- There shall be a plastic drawer in each of the lockers with a possibility to attach a label at the front side.
- The installation shall be separated into three arrangements of a cupboard type:
 - There shall be two cupboards consisting of about 100 lockers in each. The outside dimension of each these 2 cupboards shall not exceed the length of 2.20 meters. The lockers in the upper row shall be in height of about 1.60 meters and the lower lockers shall be 50-60 cm above the ground floor.

- There shall be a third cupboard with about 40 lockers. The dimensions of the third locker cupboard shall be similar to the two others so that the lower row of lockers shall be about 60 cm from ground level and the upper row shall be in height of not more than 160 cm above ground level.
- The three installations shall stand on a rack type support.
- The installation will be placed inside the building on PVC covered concrete floor and only fixed against the wall.
- The side walls of the cupboards may be painted (RAL colour to be defined) but individual locker's front doors shall be made of polished or brushed metal surface.
- The installation is under permanent surveillance and there are no specific safety requirements. However, the lockers shall be burglar-proof against the use of normal housebreaking tools.

As a supplement to these cupboard arrangements, two drop off safes shall be delivered. The safes shall be similar to a cashdrop system used by banks. The drop off safes shall allow for depositing of a number of the above described items in each of these safes. The drop off safes shall stand beside each of the locker arrangements.

The contractor shall ensure full warranty over a period of two years following the acceptance of the work by the Commission which shall include the provision of on-site repair work for all parts of the installation at the latest 3 working days following a request for repair.

I.3. Timetable to observe

Execution of the tasks begins after the date on which the Contract enters into force.

In principle, the deadlines set out below cannot be extended. The Contractor is deemed solely responsible for delays occasioned by subcontractors or other third parties (except for rare cases of *force majeure*). Adequate resources and appropriate organisation of the work including management of potential delays should be put in place in order to observe the timetable below.

A kick-off meeting will take place in the Commission EUROFORUM office building in Luxembourg at the latest 20 days following the signature of the contract. During this meeting all remaining technical and administrative details shall be discussed in particular the services to be provided by the Contractor for the reception, the transport, setting up the installation inside the building.

I.3.1. Design of the installation:

The Contractor shall inform the Commission DG ENER Health Protection Sector (HPS) in Luxembourg, after the final design of the installation has been established. The DG ENER HPS shall have 45 work days to approve the design before the production of the installation will start.

I.3.2. Setting up of the installation:

The Contractor shall inform the Commission DG ENER Health Protection Sector and the Office for Infrastructure in Luxembourg, OIL, at the latest 14 days before the foreseen setting up of the installation inside the EUFO building. The names of the workers in charge with the setting up of the installation have to be submitted together with this information.

I.3.3. Repair services:

During the two years warranty period the contractor shall provide repair work for all parts of the installation at the latest 3 working days following a request for repair.

I.4. Duration of the tasks

The duration of the tasks shall not exceed 18 months. This period is calculated in calendar days.

I.5. Place of performance

The tasks will be performed on the Contractor's premises. However, meetings between the contractor and the Commission may be held on Commission premises in Luxembourg.

I.6. Estimate of the amount of work involved

The amount of work involved to carry out this contract is assessed at 120 man-days.

DRAWING 1

DRAFT DESIGN OF DEPOSIT BOXES ARRANGEMENT

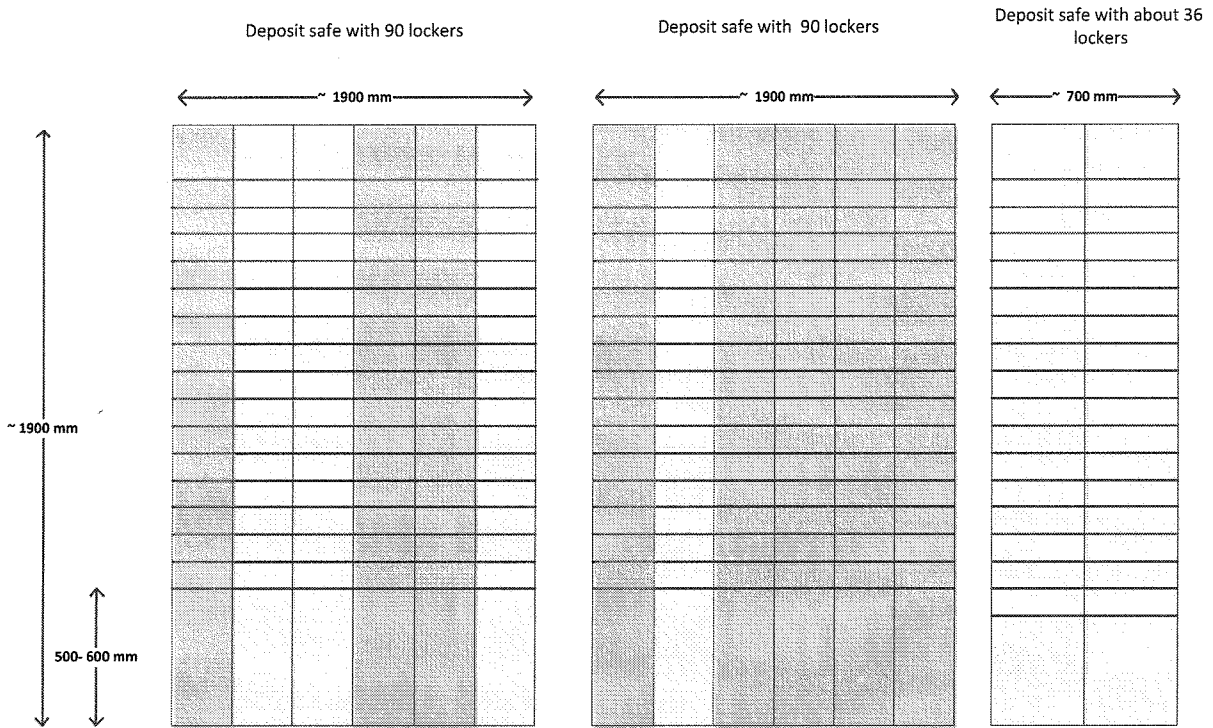

Dimensions of inside box

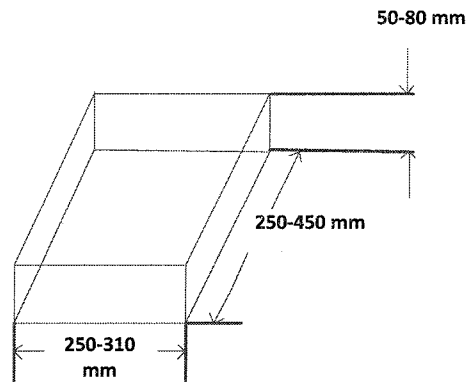

II. TERMS OF CONTRACT

In drawing up his offer, the tenderer should bear in mind the provisions of the draft contract attached to this invitation to tender (Annex 6). Any limitation, amendment or denial of the terms of contract will lead to automatic exclusion from the procurement procedure.

The Commission may, before the contract is signed, either abandon the procurement procedure or cancel the award procedure without the tenderers being entitled to claim any compensation.

II.1. Terms of payment

Payments shall be made in accordance with the provisions specified in Annex 6, the draft supply contract.

II.2. Subcontracting

If the tenderer intends to subcontract part of the service, he shall indicate in his offer which part will be subcontracted and to what extent (% of the total contract value).

Tenderers must ensure that Article II.18 of the contract (Annex 6) can be applied to subcontractors. Once the contract has been signed, Article II.6 of the above-mentioned contract shall govern the subcontracting.

II.3. Joint tenders

In case of a joint tender submitted by a group of tenderers, these latter will be regarded as partners. If awarded the contract, they will have an equal standing towards the contracting authority in the execution of the contract.

The tenderers should indicate in their offer whether the partnership takes the form of:

a) a new or existing legal entity which will sign the contract with the Commission in case of award

or

b) a group of partners not constituting a new legal entity, who via a power of attorney, signed by an authorised representative of each partner (except the lead partner), designate one of the partners as lead partner, and mandate him as lead contractor to sign the contract with the Commission in case of award.

If the contractor is a grouping or consortium of two or more persons, all such persons shall be jointly and severally liable to the Commission for the fulfilment of the terms and conditions of the contract. Such persons shall designate one of them to act as leader with full authority to bind the grouping or the consortium and each of its members. It shall be responsible for the receipt and processing of payments for members of the grouping, for managing the service administration and for coordination. The composition and constitution of the grouping or consortium, and the allocation of the scope of tasks amongst the members, shall not be altered without the prior written consent of the Commission which can be withheld at discretion.

III. FORM AND CONTENT OF THE TENDER

III.1. General

Tenders must be written in **one of the official languages** of the European Union and submitted in **triplicate** (one clearly marked "original" and two copies) as well as a copy of the offer on a CD/DVD. The attention of the tenderers is drawn to the fact that the majority of the deliverables requested under Specific Contracts will have to be submitted in English.

Tenders must be clear and concise, with continuous page numbering, and assembled in a coherent fashion (e.g. bound or stapled).

The original signature of the single tenderer's or lead partner's authorised representative) (preferably in blue ink) on the administrative identification form (Annex 1) shall be considered as the signature of the tender, binding the single tenderer or the group of partners to the terms included in the tender.

III.2. Structure of the tender

All tenders must include three sections i.e. an administrative, a technical and a financial proposal.

III.2.1. Section One: administrative proposal

This section must provide the following information, set out in the standard identification forms attached to these tender specifications (Annexes 1, 2, 3, 4 and 5 as well other evidence required):

- Tenderers' identification (Annex 1)
 - All tenderers must provide proof of **registration**, as prescribed in their country of establishment, on one of the **professional or trade registers** or provide a declaration or certificate.
 - If the tenderer is a natural person, he/she must provide a copy of the identity card/passport or driving licence and proof that he/she is covered by a social security scheme as a self-employed person.

Each tenderer (including subcontractor(s) or any member of a consortium or grouping) must complete and sign the identification forms in Annex 1 and also provide above-mentioned documents. However, the subcontractor(s) shall not be required to fill in or provide those documents when the services represent less than 20% of the contract.

- Financial identification (Annex 2)

The **bank identification form** must be filled in and signed by an authorised representative of the tenderer and his/her banker. A standard form is attached in Annex 2 and a specific form for each Member State is available at the following Internet address:

http://ec.europa.eu/budget/contracts_grants/info_contracts/financial_id/financial_id_en.cfm

In the case of a grouping, this form must only be provided by the person heading the project only.

If the corresponding bank account of economic operators is already registered in the Commission's files they are not obliged to provide a new form on the condition that they confirm that no change in the information already provided has occurred. In case of doubt, we recommend submitting a new form.

- Legal entities (Annex 3)

The legal entity form in Annex 3 must be filled in and should be accompanied by a number of supporting documents, available on the Web site:

http://ec.europa.eu/budget/contracts_grants/info_contracts/legal_entities/legal_entities_en.cfm

In the case of a grouping, this form must be provided by all partners.

Economic operators already registered as a legal entity in the Commission's files (i.e. they are or have been contractors of the Commission) are not obliged to provide a new form on the condition that they confirm that no change in the information already provided has occurred. In case of doubt, we recommend submitting a new form.

- Declaration of honour with respect to the Exclusion criteria and absence of conflict of interest (Annex 4)

An original should be filled and signed by (an) authorised representative(s) of all partners. Only sub-contractors with a part of the contract above 20% should sign the form.

- Power of attorney (Annex 5) – in case of grouping only

An original should be filled and signed by (an) authorised representative(s) of each partner.

- All the supporting documentation for the purpose of checking the selection criteria (IV.2) should also be submitted under this section

The Commission reserves the right, however, to request clarification or additional evidence in relation to the bid submitted for evaluation or verification purposes within a time-limit stipulated in its request.

III.2.2. Section Two: Technical proposal

This section is of great importance in the assessment of the bids, the award of the contract and the future execution of any resulting contract.

The award criteria as set out in chapter IV.3 define those parts of the technical proposal to which the tenderers should pay particular attention as they will be the ground for the evaluation of the quality of the proposal.

III.2.3. Section Three: Financial proposal

All tenders must contain a financial proposal. The tenderer's attention is drawn to the following points:

- Prices must be quoted in **euros**, including the countries which are not in the euro-area. As far as the tenderers of those countries are concerned, they cannot change the amount of the bid because of the evolution of the exchange rate. The tenderers choose the exchange rate and assume all risks or opportunities relating to the rate fluctuation.
- Prices must be fixed amounts and include all expenses, such as travel expenses and daily allowances.
- **Prices must be quoted free of all duties, taxes and other charges, i.e. also free of VAT**, as the European Union is exempt from such charges in the EU under Articles 3 and 4 of the Protocol on the Privileges and Immunities annexed to the Treaty on the Functioning of the European Union. Exemption is granted to the Commission by the governments of the Member States, either through refunds upon presentation of documentary evidence or by direct exemption. For those countries where national legislation provides an exemption by means of a reimbursement, the amount of VAT is to be shown separately. In case of doubt about the applicable VAT system, it is the tenderer's responsibility to contact his or her national authorities to clarify the way in which the European Union is exempt from VAT;
- **Prices shall be fixed** and not subject to revision during the performance of the contract;
- For each category of staff involved in the project, the tenderer must specify:
 - the total labour costs;
 - **the daily rates and total number of days** (man/days) each member of staff will contribute to the project;
 - other categories of costs, indicating the nature of the cost, the total amount, the unit price and the quantity.

Bids involving more than one service provider (consortium) must specify the amounts indicated above for each provider.

IV. ASSESSMENT AND AWARD OF THE CONTRACT

Participation in tendering procedures is open on equal terms to all natural and legal persons coming within the scope of the Treaties and to all natural and legal persons in a third country which has a special agreement with the Union in the field of public procurement, under the conditions laid down in that agreement.

Where the Multilateral Agreement on Public Contracts concluded within the framework of the WTO applies, the contracts are also open to nationals of states which have ratified this Agreement, under the conditions provided for therein.

The procedure for the award of the contract, which will concern only admissible bids (see requirements in the invitation to tender, in particular, regarding the deadline for submission and the presentation of the offers and packaging), will be carried out in three successive stages.

The aim of each of these stages is:

- 1) to check on the basis of the exclusion criteria, whether tenderers can take part in the tendering procedure;
- 2) to check on the basis of the selection criteria, the technical and professional capacity and economic and financial capacity of each tenderer;
- 3) to assess on the basis of the award criteria each bid which has passed the exclusion and selection stages.

The assessment will be based on each tenderer's bid. All the information will be assessed in the light of the criteria set out in these specifications.

IV.1. Exclusion criteria (exclusion of tenderers)

IV.1.1. Exclusion criteria (Article 93 Financial Regulation¹)

1. To be eligible for participating in this contract award procedure, tenderers must not be in any of the following situations:
 - (a) they are bankrupt or being wound up, are having their affairs administered by the courts, have entered into an arrangement with creditors, have suspended business activities, are the subject of proceedings concerning those matters, or are in any analogous situation arising from a similar procedure provided for in national legislation or regulations;
 - (b) they have been convicted of an offence concerning their professional conduct by a judgement which has the force of *res judicata*;
 - (c) they have been guilty of grave professional misconduct proven by any means which the contracting authority can justify;
 - (d) they have not fulfilled obligations relating to the payment of social security contributions or the payment of taxes in accordance with the legal provisions of the country in which they are established or with those of the country of the contracting authority or those of the country where the contract is to be performed;

¹ Council Regulation (EC, Euratom) No 1605/2002 of 25 June 2002 on the Financial Regulation applicable to the general budget of the European Communities (OJ L 248 of 16.9.2002)

- (e) they have been the subject of a judgement which has the force of *res judicata* for fraud, corruption, involvement in a criminal organisation or any other illegal activity detrimental to the Union's financial interests;
 - (f) they are currently subject to an administrative penalty referred to in Article 96(1) of the Financial Regulation² for being guilty of misrepresentation in supplying the information required by the contracting authority as a condition of participation in a contract procurement procedure or by the authorising officer as a condition of participation in a grant award procedure, for failing to supply this information or for having been declared to be in serious breach of their obligations under contracts or grants covered by the Union budget.
2. The cases referred to in point IV.1.1. e) above shall be the following:
- a) cases of fraud as referred to in Article 1 of the Convention on the protection of the European Communities' financial interests established by the Council Act of 26 July 1995 (OJ/C 316 of 27.11.1995, p. 48);
 - b) cases of corruption as referred to in Article 3 of the Convention on the fight against corruption involving officials of the European Communities or officials of Member States of the European Union, established by the Council Act of 26 May 1997 (OJ/C 195 of 25.6.1997, p. 1);
 - c) cases of involvement in a criminal organisation, as defined in Article 2(1) of Joint Action 98/733/JHA of the Council (OJ/L 315 of 29.12.1998, p. 1);
 - d) cases of money laundering as defined in Article 1 of Council Directive 91/308/EEC (OJ/L 166 of 28.6.1991, p.77).

IV.1.2. Other cases of exclusion

1. In accordance with Article 94 Financial Regulation, contracts will not be awarded to tenderers who, during the procurement procedure:

- a) **are subject to a conflict of interest;**

Tenderers must declare:

- that they do not have any conflict of interest in connection with the contract; a conflict of interest could arise in particular as a result of economic interests, political or national affinities, family or emotional ties, or any other relevant connection or shared interest;
- that they will inform the contracting authority, without delay, of any situation constituting a conflict of interest or which could give rise to a conflict of interest;
- that they have not made and will not make any offer of any type whatsoever from which an unjustified advantage can be derived under the contract;
- that they have not granted and will not grant, have not sought and will not seek, have not attempted and will not attempt to obtain, and have not accepted and will not accept, any advantage, financial or in kind, to or from any party whatsoever, where such advantage constitutes an illegal practice or involves corruption, either directly or indirectly, inasmuch as it is an incentive or reward relating to performance of the Contract.

² Council Regulation (EC, Euratom) n° 1605/2002 of 25 June 2002 on the Financial regulation applicable to the general budget of the European Communities, OJ L 248 of 16 September 2002, p. 1, amended by Council Regulation (EC, Euratom) n° 1995/2006 of 13 December 2006, OJ L 390 of 30 December 2006, p.1.

The Commission reserves the right to check the above information.

- b) **are guilty of misrepresentation** in supplying the information required by the contracting authority as a condition of participation in the procurement procedure or fail to supply this information.
- c) find themselves in one of the **situations of exclusion**, referred to in paragraph IV.1.1. above for this procurement procedure.

2. As mentioned under section III.2.1., the tenderers must provide proof of **registration**, as prescribed in their country of establishment, on one of the professional or trade registers or provide a declaration or certificate.

IV.1.3. Evidence to be provided by the tenderers

1. When submitting their bids, each tenderer (including subcontractor(s) or any member of a consortium or grouping) shall provide a declaration on their honour, duly signed and dated, stating that they are not in one of the situations mentioned above (cf. IV.1.1 and VI.1.2). For that purpose, they must complete and sign the form attached in Annex 4. Where the tenderer is a legal entity, they shall, whenever requested by the Commission, provide information on the ownership or on the management, control and power of representation of the legal entity.
2. The tenderer to whom the contract is to be awarded shall provide, within 15 calendar days after notification of the results of the procurement procedure and in any case before the signature of the contract, the following evidence, confirming the declaration referred to above:

The Commission shall accept, as satisfactory evidence that the tenderer is not in one of the situations described in point IV.1.1 (a), (b) or (e) above, a recent extract from the judicial record or, failing that, an equivalent document recently issued by a judicial or administrative authority in the country of origin or provenance showing that those requirements are satisfied.

The Commission accepts, as satisfactory evidence that the tenderer is not in the situation described in point IV.1.1 (d) above, a recent certificate issued by the competent authority of the State concerned.

Where no such document or certificate is issued in the country concerned, it may be replaced by a sworn or, failing that, a solemn statement made by the interested party before a judicial or administrative authority, a notary or a qualified professional body in his country of origin or provenance.

3. Depending on the national legislation of the country in which the candidate or tenderer is established, the documents referred to in paragraph 1 and 2 above shall relate to legal and/or natural persons including, if applicable with regard to points b) and e), company directors or any person with powers of representation, decision-making or control in relation to the tenderer.
4. When the subcontracted part is above 20% of the contract value, the subcontractor(s) must also provide the above-mentioned declaration on honour. In case of doubt on this declaration on the honour, the contracting authority may also request the evidence referred to in paragraphs 2 and 3 above.

5. The Commission reserves the right to request any other document relating to the proposed tender for evaluation and verification purpose, within a delay determined in its request.

Remark:

The tenderers will be waived of the obligation to submit the documentary evidence above mentioned if such evidence has already been submitted for the purposes of another procurement procedure launched by the Directorates General in charge of Energy or Transport and provided that the documents are not more than one year old starting from their issuing date and that they are still valid. In such a case, the tenderer shall declare on his honour that the documentary evidence has already been provided in a previous procurement procedure, specifying the reference of the call for tender for which the documents have been provided, and confirm that no changes in his situation have occurred.

IV.1.4. Administrative and financial penalties

Without prejudice to the application of penalties laid down in the contract, candidates or tenderers and contractors who have been found guilty of misrepresentation in supplying the information required by the contracting authority as a condition of participation in the procurement procedure or have failed to supply this information or have been declared to be in serious breach of their obligations under contracts covered by the Union budget may be subject to administrative or financial penalties, in accordance with Article 96 of the Financial Regulation and Articles 134b and 133a of the Implementing Rules.³

IV.2. SELECTION CRITERIA (SELECTION OF TENDERERS)

To be eligible, the tenderers must have the economic and financial capacity as well as the technical and professional capacity to perform the tasks required in this call for tender.

IV.2.1. Economic and financial capacity – Criteria and references required

Tenderers shall provide evidence of their economic and financial capacity by submitting an average annual turnover of minimum 200.000 EUR over a period of the past three years.

Evidence of this capacity shall be furnished on the basis of the following documents: the balance sheets or extracts from balance sheets for the last three financial years, and a statement of overall turnover and turnover relating to the relevant supplies for the last three financial years.

An economic operator may, where appropriate and for a particular contract, rely on the capacities of other entities, regardless of the legal nature of the links which it has with them. It must in that case prove to the contracting authority that it will have at its disposal the resources necessary for performance of the contract, for example by producing an undertaking on the part of those entities to place those resources at its disposal.

³ Commission Regulation (EC, Euratom) n° 2342/2002 of 23 December 2002 laying down detailed rules for the implementation of Council Regulation (EC, Euratom) No 1605/2002 on the Financial Regulation applicable to the general budget of the European Communities, OJ L 357 of 31 December 2002, p. 1, as amended.

Under the same conditions, a consortium of economic operators may rely on the capacities of members of the consortium or of other entities.

IV.2.2. Technical and professional capacity – Criteria and references required

Tenderers should demonstrate their administrative, technical and professional capacities for the realisation of the envisaged project.

The tenderer shall have:

- 1: realised, in the past three years, at least two contracts similar to the envisaged deposit boxes arrangement or about products manufactured in the field of physical protection infrastructure such as bank safes or deposit arrangements for valuables.
- 2: an appropriate infrastructure for the manufacturing the deposit boxes arrangement.
- 3: an organised service, which is in a position to service the deposit boxes inside the EUFO building in Luxemburg for urgent repair.

The following proof is requested in order to check that the above criteria are fulfilled:

- 1: A list of contracts, realised by the tenderer as contractor in the past three years, similar to the envisaged deposit boxes arrangement or about products manufactured in the field of physical protection infrastructure such as bank safes or deposit arrangements for valuables.
- 2: Description of the infrastructure for the manufacturing of the installation.
- 3: Description of the e infrastructure for urgent repair services.

If several service providers/subcontractors are involved in the bid, each of them must have and show that they have the professional and technical capacity to perform the tasks assigned to them.

IV.3. EVALUATION OF TENDERS – AWARD CRITERIA

The contract will be awarded according to the criteria given below, on the basis of the economically most advantageous tender.

Only bids that have reached a total score of a minimum of 70% and a minimum score of 60 % for each criterion will be taken into consideration for awarding the contract.

- a) Technical evaluation criteria in their order of importance as weighted by percentage

N°	Award Criteria	Weighting
1	<u>Understanding</u> : This criterion serves to assess whether the tenderers have fully understood the concept of the deposit boxes arrangement and of the required design of the deposit boxes arrangement for small size valuables as described under point I.2.	20
2	<u>Methodology</u> : The offers will be assessed according to whether the proposed design, technical features and operationalibility of the deposit boxes meets the requirements and objectives as laid down in this call for tender.	60
3	<u>Management of repair services</u> : Assessment how the contractor organises the repair services in order to manage a short notice repair work within 3 working days.	20
Total number of points		100

b) Total price

The contract will be awarded to the tender, which offers the best ratio quality/price.

IV.4. INFORMATION FOR TENDERERS

The Commission will inform tenderers of decisions reached concerning the award of the contract, including the grounds for any decision not to award a contract or to recommence the procedure.

Upon written request, the Commission will inform the rejected tenderers of the reasons for their rejection and the tenderers having submitted an admissible tender of the characteristics and relative advantages of the selected tender and the name of the successful tenderer.

However, certain information may be withheld where its release would impede law enforcement or otherwise be contrary to the public interest, or would prejudice the legitimate commercial interests of economic operators, public or private, or might prejudice fair competition between them.

V. ANNEXES

1. Identification of the Tenderer
2. Financial Identification
3. Legal Entity Form
4. Declaration by the Tenderer (relating to the exclusion criteria and absence of conflict of interest)
5. Power of Attorney (mandate in case of joint tender)
6. Draft Contract

ANNEX 1

IDENTIFICATION OF THE TENDERER

(Each service provider, including subcontractor(s) or any member of a consortium or grouping, must complete and sign this identification form)

Call for tender ENER/D4/2012-104-3

Identity	
Name of the tenderer	
Legal status of the tenderer	
Date of registration	
Country of registration	
Registration number	
VAT number	
Description of statutory social security cover (at the level of the Member State of origin) and non-statutory cover (supplementary professional indemnity insurance) ⁴	
Address	
Address of registered office of tenderer	
Where appropriate, administrative address of tenderer for the purposes of this invitation to tender	
Contact Person	
Surname: First name: Title (e.g. Dr, Mr, Ms) : Position (e.g. manager): Telephone number: Fax number: E-mail address:	
Legal Representatives	

⁴ For natural persons

Names and function of legal representatives and of other representatives of the tenderer who are authorised to sign contracts with third parties	
Declaration by an authorised representative of the organisation⁵ I, the undersigned, certify that the information given in this tender is correct and that the tender is valid.	
Surname: First name:	Signature:

⁵ This person must be included in the list of legal representatives; otherwise the signature on the tender will be invalidated.

ANNEX 2

Financial identification form

(to be completed by the tenderer and his or her financial institution)

A specific form for each Member State is available at the following Internet address:

http://ec.europa.eu/budget/contracts_grants/info_contracts/financial_id/financial_id_en.cfm

In the case of a grouping, this form must only be provided by the person heading the project.

ANNEX 3

Legal entity form

Complete the legal entity form, which should be accompanied by a number of supporting documents, available on the Web site:

http://ec.europa.eu/budget/contracts_grants/info_contracts/legal_entities/legal_entities_en.cfm

Please note that we can only accept either original documents or certified copies, which must be less than 6 months old.

ANNEX 4

Declaration of honour with respect to the Exclusion Criteria and absence of conflict of interest

Each service provider, including subcontractor(s) or any member of a consortium or grouping, must sign this declaration

The undersigned [*name of the signatory of this form, to be completed*]:

- in his/her own name (*if the economic operator is a natural person or in case of own declaration of a director or person with powers of representation, decision making or control over the economic operator⁶*)
- or
- representing (*if the economic operator is a legal person*)

official name in full (*only for legal person*):

official legal form (*only for legal person*):

official address in full:

VAT registration number:

declares that the company or organisation that he/she represents / he/she:

- a) is not bankrupt or being wound up, is not having its affairs administered by the courts, has not entered into an arrangement with creditors, has not suspended business activities, is not the subject of proceedings concerning those matters, and is not in any analogous situation arising from a similar procedure provided for in national legislation or regulations;
- b) has not been convicted of an offence concerning professional conduct by a judgment which has the force of *res judicata*;
- c) has not been guilty of grave professional misconduct proven by any means which the contracting authorities can justify;
- d) has fulfilled all its obligations relating to the payment of social security contributions and the payment of taxes in accordance with the legal provisions of the country in which it is established, with those of the country of the contracting authority and those of the country where the contract is to be carried out;
- e) has not been the subject of a judgement which has the force of *res judicata* for fraud, corruption, involvement in a criminal organisation or any other illegal activity detrimental to the Union's financial interests;

⁶ To be used depending on the national legislation of the country in which the candidate or tenderer is established and where considered necessary by the contracting authority (see art. 134(4) of the Implementing Rules).

- f) is not a subject of the administrative penalty for being guilty of misrepresentation in supplying the information required by the contracting authority as a condition of participation in the procurement procedure or failing to supply an information, or being declared to be in serious breach of his obligation under contract covered by the budget.

In addition, the undersigned declares on their honour:

- g) they have no conflict of interest in connection with the contract; a conflict of interest could arise in particular as a result of economic interests, political or national affinities, family or emotional ties or any other relevant connection or shared interest;
- h) they will inform the contracting authority, without delay, of any situation considered a conflict of interest or which could give rise to a conflict of interest;
- i) they have not made and will not make any offer of any type whatsoever from which an advantage can be derived under the contract;
- j) they have not granted and will not grant, have not sought and will not seek, have not attempted and will not attempt to obtain, and have not accepted and will not accept any advantage, financial or in kind, to or from any party whatsoever, constituting an illegal practice or involving corruption, either directly or indirectly, as an incentive or reward relating to award of the contract;
- k) that the information provided to the Commission within the context of this invitation to tender is accurate, sincere and complete;
- l) that in case of award of contract, they shall provide upon request the evidence that they are not in any of the situations described in points a, b, d, e above.

For situations described in (a), (b) and (e), production of a recent extract from the judicial record is required or, failing that, a recent equivalent document issued by a judicial or administrative authority in the country of origin or provenance showing that those requirements are satisfied. Where the Tenderer is a legal person and the national legislation of the country in which the Tenderer is established does not allow the provision of such documents for legal persons, the documents should be provided for natural persons, such as the company directors or any person with powers of representation, decision making or control in relation to the Tenderer.

For the situation described in point (d) above, recent certificates or letters issued by the competent authorities of the State concerned are required. These documents must provide evidence covering all taxes and social security contributions for which the Tenderer is liable, including for example, VAT, income tax (natural persons only), company tax (legal persons only) and social security contributions.

For any of the situations (a), (b), (d) or (e), where any document described in two paragraphs above is not issued in the country concerned, it may be replaced by a sworn or, failing that, a solemn statement made by the interested party before a judicial or administrative authority, a notary or a qualified professional body in his country of origin or provenance.]

By signing this form, the undersigned acknowledges that they have been acquainted with the administrative and financial penalties described under art 133 and 134 b of the Implementing Rules (Commission Regulation 2342/2002 of 23/12/02), which may be applied if any of the declarations or information provided prove to be false.

Full name

Date

Signature

ANNEX 5

POWER OF ATTORNEY

mandating one of the partners in a joint tender as lead partner and lead contractor ⁷

The undersigned:

[Signatory (Name, Function, Company, Registered address, VAT Number)]

having the legal capacity required to act on behalf of his/her company,

HEREBY AGREES TO THE FOLLOWING:

- 1) To submit a tender as a partner in the group of partners constituted by [Company 1, Company 2, Company N], and led by [Company X], in accordance with the conditions specified in the tender specifications and the terms specified in the tender to which this power of attorney is attached.
- 2) If the European Commission awards the Contract to the group of partners constituted by [Company 1, Company 2, Company N], and led by [Company X] on the basis of the joint tender to which this power of attorney is attached, all the partners shall be co-signatories of the Contract in accordance with the following conditions:
 - (a) All partners shall be jointly and severally liable towards the European Commission for the performance of the Contract.
 - (b) All partners shall comply with the terms and conditions of the Contract and ensure the proper delivery of their respective share of the services and/or supplies subject to the Contract.
- 1) Payments by the European Commission related to the services and/or supplies subject to the Contract shall be made through the lead partner's bank account: [Provide details on bank address, account number].
- 2) The partners grant to the lead partner all the necessary powers to act on their behalf in the submission of the tender and conclusion of the Contract, including:
 - (a) The lead partner shall submit the tender on behalf of the group of partners.
 - (b) The lead partner shall sign any contractual documents — including the Contract, and Amendments thereto — and issue any invoices related to the Services on behalf of the group of partners.
 - (c) The lead partner shall act as a single contact point with the European Commission in the delivery of the services and/or supplies subject to the Contract. It shall co-ordinate the delivery of the services and/or supplies by the group of partners to the European Commission, and shall see to a proper administration of the Contract.

Any modification to the present power of attorney shall be subject to the European Commission's express approval. This power of attorney shall expire when all the contractual obligations of the group of partners towards the European Commission for the delivery of the services and/or supplies subject to the Contract have ceased to exist. The parties cannot terminate it before that date without the Commission's consent.

Signed in on [dd/mm/yyyy]

Place and date:

Name (in capital letters), function, company and signature:

⁷ To be filled in and signed by each of the partners in a joint tender, except the lead partner;

ANNEX 6 DRAFT CONTRACT



EUROPEAN COMMISSION
DIRECTORATE-GENERAL FOR ENERGY

DIRECTORATE D - Nuclear Energy
Radiation Protection

SUPPLY CONTRACT

CONTRACT NUMBER – [complete]

The European Atomic Energy Community (hereinafter referred to as "the Community"), represented by the European Commission (hereinafter referred to as "the Commission"), which is represented for the purposes of the signature of this contract by Mr Peter Faross, Director in the Directorate-General for Energy, Directorate D-Nuclear Energy,

of the one part,

and

[official name in full]

[official legal form (Delete if contractor is a natural person or a body governed by public law.)]

[statutory registration number] (Delete if contractor is a body governed by public law. For natural persons, indicate the number of their identity card or, failing that, of their passport or equivalent.)

[official address in full]

VAT registration number

(hereinafter referred to as "the Contractor"), [represented for the purposes of the signature of this contract by [forename, surname and function,]]

[The parties identified above and hereinafter collectively referred to as 'the Contractor' shall be jointly and severally liable vis-à-vis the Commission for the performance of this contract.]

of the other part

HAVE AGREED

the **Special Conditions** and the following Annexes:

- Annex I** General Conditions for supply contracts
- Annex II** Tender Specifications (Invitation to Tender No [complete] of [insert date])
- Annex III** Contractor's Tender (No [complete] of [insert date])

which form an integral part of this contract (hereinafter referred to as “the Contract”).

- The terms set out in the Special Conditions shall take precedence over those in the other parts of the Contract.
- The terms set out in the General Conditions shall take precedence over those in the other Annexes.
- The terms set out in the Tender Specifications (Annex II) shall take precedence over those in the Tender (Annex III).

Subject to the above, the several instruments forming part of the Contract are to be taken as mutually explanatory. Ambiguities or discrepancies within or between such parts shall be explained or rectified by a written instruction issued by the Commission, subject to the rights of the Contractor under Article I.7 should he dispute any such instruction.

I – SPECIAL CONDITIONS

ARTICLE I.1 - SUBJECT

- I.1.1** The subject of the Contract is the delivery and installation of an arrangement consisting of 240 small size deposit lockers.
- I.1.2** The Contractor shall deliver and assemble the supplies and shall provide the services related to them in accordance with the Tender Specifications annexed to the Contract (Annex II).

ARTICLE I.2 - DURATION AND DELIVERY

- I.2.1** The Contract shall enter into force on the date on which it is signed by the last contracting party.
- I.2.2** Under no circumstances may implementation commence before the date on which the Contract enters into force.
- I.2.3** Delivery of supplies and installation shall be completed within **18 months** after the Contract enters into force. This period and all other periods specified in the Contract are calculated in calendar days.
- I.2.4** The supplies shall be delivered at the following address:

European Commission
Directorate-General for Energy
Euroforum Building
L-2920 Luxembourg

To the attention of: Mr Leonardo ARTESE or Mr Alain CLUZEAU

The Contractor shall notify the Commission of the exact date of delivery at least 10 days in advance. All deliveries shall be made between 09:00 hours and 16:30 hours at the agreed place of delivery.

ARTICLE I.3 - CONTRACT PRICE

- I.3.1** The total amount to be paid by the Commission under the Contract shall be EUR [*amount in figures and in words*] covering the manufacture, delivery and assembly of all the supplies and the provision of related services.
- I.3.2** Prices shall be expressed in EUR.

ARTICLE I.4 –PAYMENTS

I.4.1 Payment of the balance

Within sixty days of receipt of the certificate of conformity of the supplies signed by the Commission, the Contractor shall submit an admissible invoice indicating the reference number of the Contract for payment of the balance.

Payment shall be made within thirty days of the receipt of the invoice.

For Contractors established in Belgium, the provisions of the Contract constitute a request for VAT exemption No 450, provided the Contractor includes the following statement in his invoice(s): “Exonération de la TVA, article 42, paragraphe 3.3 du code de la TVA (circulaire 2/1978)” or an equivalent statement in the Dutch or German language.

ARTICLE I.5 – BANK ACCOUNT

Payments shall be made to the Contractor’s bank account denominated in euro, identified as follows:

Name of bank:
Address of branch in full:
Exact designation of account holder:
Full account number including codes:
IBAN code:

ARTICLE I.6 – GENERAL ADMINISTRATIVE PROVISIONS

Any communication relating to the Contract shall be made in writing in paper or electronic form and shall bear the Contract number. Ordinary mail shall be deemed to have been received by the Commission on the date on which it is registered by the department responsible indicated below.

Electronic communication must be confirmed by paper communication when requested by any of the parties. The parties agree that paper communication can be replaced by electronic communication with electronic signature.

Communications shall be sent to the following addresses:

Commission:
European Commission
Directorate-General for Energy
Financial and Contractual Cell
Mr Alain Cluzeau – EUFO 4475
L-2920 Luxembourg

Contractor:
Mr/Mrs/Ms [*complete*]
[*Function*]
[*Company name*]
[*Official address in full*]

ARTICLE I.7 APPLICABLE LAW AND SETTLEMENT OF DISPUTES

I.7.1 The Contract shall be governed by Community and European Union law, complemented, where necessary, by the national substantive law of Luxembourg.

I.7.2 Any dispute between the parties resulting from the interpretation or application of the Contract which cannot be settled amicably shall be brought before the courts of Luxembourg.

ARTICLE I.8 – DATA PROTECTION

Any personal data included in the Contract shall be processed pursuant to Regulation (EC) No 45/2001 on the protection of individuals with regard to the processing of personal data by the Community institutions and bodies and on the free movements of such data. Such data shall be processed solely for the purposes of the performance, management and monitoring of the Contract by the Director of the Shared Resource Directorate MOVE/ENER acting as data controller without prejudice to possible transmission to the bodies charged with monitoring or inspection task in application of the Community and European Union law.

ARTICLE I.9 – TERMINATION BY EITHER CONTRACTING PARTY

Either contracting party may, of its own volition and without being required to pay compensation, terminate the Contract by serving 14 days formal prior notice. Should the Commission terminate the Contract, the Contractor shall only be entitled to payment corresponding to the supplies delivered before the termination date. Article II.13.4 applies accordingly.

ARTICLE I.10 – CONTRACT CONCLUDED DURING STANDSTILL PERIOD

In case this Contract was signed by both the Commission and the Contractor before the expiry of 14 calendar days from the day after simultaneous dispatch of information about the award decisions and decisions to reject, this Contract shall be null and void.

This article is not applicable for contracts not covered by Directive 2004/18/EC and in cases indicated in Article 158a(2) of the rules for the implementation of the Financial Regulation (Regulation No 2342/2002).

SIGNATURES

For the Contractor,

[*Company name/forename/surname/function*]

signature[s]: _____

Done at _____, [date]

For the Commission,

Peter Faross, Director

signature: _____

Done at Luxembourg, [date]

In duplicate in English.

ANNEX I

II – GENERAL CONDITIONS FOR SUPPLY CONTRACTS

ARTICLE II.1 - PERFORMANCE OF THE CONTRACT

II.1.1 Delivery

a) Time allowed for delivery

The time allowed for delivery shall be calculated in accordance with Article I.2.

b) Date, time and place of delivery

The Commission shall be notified in writing of the exact date of delivery within the period indicated in Article I.2. All deliveries shall be made at the agreed place of delivery during the hours indicated in Article I.2.

The Contractor shall bear all costs and risks involved in delivering the supplies to the place of delivery.

c) Consignment note

Each delivery shall be accompanied by a consignment note in duplicate, duly signed and dated by the Contractor or his carrier, giving the Contract number and particulars of the supplies delivered. One copy of the consignment note shall be countersigned by the Commission and returned to the Contractor or to his carrier.

II.1.2 Certificate of conformity

Signing of the consignment note by the Commission, as provided for in subparagraph II.1.1 c) above, is simply an acknowledgment of the fact that the delivery took place and in no way implies conformity of the supplies with the Contract.

Conformity of the supplies delivered shall be evidenced by the signing of a certificate to this effect by the Commission no later than one month after the date of delivery, unless provision is made for a different period in the Special Conditions or in Annex II.

Conformity shall be declared only where the conditions laid down in the Contract are satisfied and the supplies conform to Annex I.

Where, for reasons attributable to the Contractor, the Commission is unable to accept the supplies, the Contractor shall be notified in writing at the latest by the deadline for conformity.

II.1.3 Conformity of the supplies delivered with the Contract

a) The supplies delivered by the Contractor to the Commission must be in conformity in quantity, quality, price and packaging with the Contract.

b) The supplies delivered must:

- correspond to the description given in Annex II and possess the characteristics of the supplies supplied by the Contractor to the Commission as a sample or model;
- be fit for any specific purpose required of them by the Commission and made known to the Contractor at the time of conclusion of the Contract and accepted by the Contractor;

- be fit for the purposes for which supplies of the same type are normally used;
- demonstrate the quality and performance which are normal in supplies of the same type and which the Commission can reasonably expect, given the nature of the supplies and taking into account any public statements on the specific characteristics of the supplies made by the Contractor, the producer or his representative, particularly in advertising or on labelling;
- be packaged according to the usual method for supplies of the same type or, failing this, in a way designed to preserve and protect them.

II.1.4 Remedy

- a) The Contractor shall be liable to the Commission for any lack of conformity which exists at the time the supplies are verified.
- b) In case of lack of conformity, without prejudice to Article II.11 regarding liquidated damages applicable to the total price of the supplies concerned, the Commission shall be entitled:
 - either to have the supplies brought into conformity, free of charge, by repair or replacement;
 - or to have an appropriate reduction made in the price.
- c) Any repair or replacement shall be completed within a reasonable time and without any significant inconvenience to the Commission, taking account of the nature of the supplies and the purpose for which they are required by the Commission.
- d) The term 'free of charge' in paragraph b) refers to the costs incurred to bring the supplies into conformity, particularly the cost of postage, labour and materials.

II.1.5 Assembly

If required by Article I.1.2 of the Special Conditions, the Contractor shall assemble the supplies delivered within a period of one month unless otherwise specified in the Special Conditions or in Annex I.

Any lack of conformity resulting from incorrect installation of the supplies delivered shall be deemed to be equivalent to lack of conformity of the supplies if installation forms part of the Contract and the supplies were installed by the Contractor or under his responsibility. This shall apply equally if the product was to be installed by the Commission and was incorrectly installed owing to a shortcoming in the installation instructions.

II.1.6 Services provided to supplies

If required by Article I.1.2 or Annex II, services to supplies shall be provided accordingly.

II.1.7 General provisions concerning supplies

a) Packaging

The supplies shall be packaged in strong boxes or crates or in any other way that ensures that the contents remain intact and prevents damage or deterioration. Packaging, pallets, etc., including contents, shall not weigh more than 500 kg.

Unless otherwise specified in the Special Conditions or in Annex II, pallets shall be considered as one-way packaging and shall not be returned. Each box shall be clearly labelled with the following information:

- European Commission and address for delivery;
- name of Contractor;

- description of contents;
- date of delivery;
- EC code number of article.

b) Guarantee

The supplies shall be guaranteed against all defects in manufacture or materials for two years from the date of delivery, unless provision is made for a longer period in Annex I.I.

The Contractor shall guarantee that any permits and licences required for manufacturing and selling the supplies have been obtained.

The Contractor shall replace at his own expense, within a reasonable time limit to be determined by agreement between the parties, any items which become damaged or defective in the course of normal use during the guarantee period.

The Contractor is responsible for any conformity defect which exists at the time of delivery, even if this defect does not appear until a later date.

The Contractor is also responsible for any conformity defect which occurs after delivery and is ascribable to non-compliance with his obligations, including failure to provide a guarantee that, for a certain period, supplies used for the purposes for which they are normally used or for a specific purpose will preserve their qualities or characteristics as specified.

If part of an item is replaced, the replacement part shall be guaranteed under the same terms and conditions for a further period of the same duration as that specified above.

If a defect is found to originate in a systematic flaw in design, the Contractor must replace or modify all identical parts incorporated in the other supplies that are part of the Contract, even though they may not have been the cause of any incident. In this case, the guarantee period shall be extended as stated above.

II.1.8 General provisions on performance of the Contract

- a) The Contractor shall perform the Contract to the highest professional standards. The Contractor shall have sole responsibility for complying with any legal obligations incumbent on him, notably those resulting from employment, tax and social legislation.
- b) The Contractor shall have sole responsibility for taking the necessary steps to obtain any permit or licence required for performance of the Contract under the laws and regulations in force at the place where the tasks assigned to him are to be executed.
- c) The Contractor must ensure that any staff performing the Contract has the professional qualifications and experience required for execution of the tasks assigned to him.
- d) In the event of disruption resulting from the action of a member of the Contractor's staff working on Commission premises or in the event of the expertise of a member of the Contractor's staff failing to correspond to the profile required by the Contract, the Contractor shall replace him without delay. The Commission shall have the right to request the replacement of any such member of staff, stating its reasons for so doing. Replacement staff must have the necessary qualifications and be capable of performing the Contract under the same contractual conditions. The Contractor shall be responsible for any delay in the execution of the tasks assigned to him resulting from the replacement of staff.

- e) Should any unforeseen event, action or omission directly or indirectly hamper execution of the Contract, either partially or totally, the Contractor shall immediately and at his own initiative record it and report it to the Commission. The report shall include a description of the problem and an indication of the date on which it started and of the remedial action taken by the Contractor to ensure full compliance with his obligations under the Contract. In such event the Contractor shall give priority to solving the problem rather than determining liability.
- f) Should the Contractor fail to perform his obligations under the Contract, the Commission may - without prejudice to its right to terminate the Contract - reduce or recover payments in proportion to the scale of the failure. In addition, the Commission may claim compensation or impose liquidated damages provided for in Article II.11.

ARTICLE II.2 - LIABILITY

- II.2.1** The Commission shall not be liable for damage sustained by the Contractor in performance of the Contract except in the event of wilful misconduct or gross negligence on the part of the Commission.
- II.2.2** The Contractor shall be liable for any loss or damage sustained by the Commission in performance of the Contract, including in the event of subcontracting under Article II.6 up to only up to three times the total amount of the Contract. Nevertheless, if the damage or loss is caused by the gross negligence or wilful misconduct of the Contractor or by its employees, the Contractor shall remain liable without any limitation as to the amount of the damage or loss.
- II.2.3** The Contractor shall provide compensation in the event of any action, claim or proceeding brought against the Commission by a third party as a result of damage caused by the Contractor in performance of the Contract.
- II.2.4** In the event of any action brought by a third party against the Commission in connection with performance of the Contract, the Contractor shall assist the Commission. Expenditure incurred by the Contractor to this end may be borne by the Commission.
- II.2.5** The Contractor shall take out insurance against risks and damage relating to performance of the Contract if required by the relevant applicable legislation. He shall take out supplementary insurance as reasonably required by standard practice in the industry. A copy of all the relevant insurance contracts shall be sent to the Commission should it so request.

ARTICLE II.3 - CONFLICT OF INTERESTS

- II.3.1** The Contractor shall take all necessary measures to prevent any situation that could compromise the impartial and objective performance of the Contract. Such conflict of interests could arise in particular as a result of economic interest, political or national affinity, family or emotional ties, or any other relevant connection or shared interest. Any conflict of interests which could arise during performance of the Contract must be notified to the Commission in writing without delay. In the event of such conflict, the Contractor shall immediately take all necessary steps to resolve it.

The Commission reserves the right to verify that such measures are adequate and may require that additional measures be taken, if necessary, within a time limit which it shall set. The Contractor shall ensure that his staff, board and directors are not placed in a situation which could give rise to conflict of interest. Without prejudice to Article II.1 the Contractor

shall replace, immediately and without compensation from the Commission, any member of his staff exposed to such a situation.

II.3.2 The Contractor shall abstain from any contact likely to compromise his independence.

II.3.3 The Contractor declares:

- that he has not made, and will not make, any offer of any type whatsoever, from which an unjustified advantage can be derived under the Contract,
- that he has not granted and will not grant, has not sought and will not seek, has not attempted and will not attempt to obtain, and has not accepted and will not accept, any advantage, financial or in kind, to or from any party whatsoever, here such advantage constitutes an illegal practice or involves corruption, either directly or indirectly, inasmuch as it is an incentive or reward relating to the performance of the Contract.

II.3.4. The Contractor shall pass on all the relevant obligations in writing to his staff, board, and directors as well as to third parties involved in performance of the Contract.

ARTICLE II.4 – CONFIDENTIALITY

II.4.1 The Contractor undertakes to treat in the strictest confidence and not make use of or divulge to third parties any information or documents which are linked to performance of the Contract. The Contractor shall continue to be bound by this undertaking after completion of the tasks.

II.4.2 The Contractor shall obtain from each member of his staff, board and directors an undertaking that they will respect the confidentiality of any information which is linked, directly or indirectly, to execution of the tasks and that they will not divulge to third parties or use for their own benefit or that of any third party any document or information not available publicly, even after completion of the tasks.

ARTICLE II.5 DATA PROTECTION

II. 5.1 The Contractor shall have the right of access to his/her personal data and the right to rectify any such data. Should the Contractor have any queries concerning the processing of his/her personal data, he shall address them to entity acting as data controller provided for in Article I.8.

II. 5.2 The Contractor shall have right of recourse at any time to the European Data Protection Supervisor.

II. 5.3 Where the Contract requires the processing of personal data by the Contractor, the Contractor may act only under the supervision of the data controller, in particular with regard to the purposes of the processing, the categories of data which may be processed, the recipients of the data, and the means by which the data subject may exercise his/her rights.

II. 5.4 The Contractor shall limit access to the data to the staff strictly necessary for the performance, management and monitoring of the Contract.

II. 5.5 The Contractor undertakes to adopt appropriate technical and organisational security measures having regard to the risks inherent in the processing and to the nature of the personal data concerned in order to:

- a) prevent any unauthorised person from having access to computer systems processing personal data, and especially:
 - aa) unauthorised reading, copying, alteration or removal of storage media;
 - ab) unauthorised data input as well as any unauthorised disclosure, alteration or erasure of stored personal data;
 - ac) unauthorised use of data-processing systems by means of data transmission facilities;
- b) ensure that authorised users of a data-processing system can access only the personal data to which their access right refers;
- c) record which personal data have been communicated, when and to whom;
- d) ensure that personal data being processed on behalf of third parties can be processed only in the manner prescribed by the contracting institution or body;
- e) ensure that, during communication of personal data and transport of storage media, the data cannot be read, copied or erased without authorisation;
- f) design its organisational structure in such a way that it meets data protection requirements.

ARTICLE II.6 – SUBCONTRACTING

II.6.1 The Contractor shall not subcontract without prior written authorisation from the Commission nor cause the Contract to be performed in fact by third parties.

II.6.2 Even where the Commission authorises the Contractor to subcontract to third parties, he shall none the less remain bound by his obligations to the Commission under the Contract and shall bear exclusive liability for proper performance of the Contract.

II.6.3 The Contractor shall make sure that the subcontract does not affect rights and guarantees to which the Commission is entitled by virtue of the Contract, notably Article II.18.

ARTICLE II.7 - AMENDMENTS

Any amendment to the Contract shall be the subject of a written agreement concluded by the contracting parties before fulfilment of all their contractual obligations. An oral agreement shall not be binding on the contracting parties.

ARTICLE II.8 – ASSIGNMENT

II.8.1 The Contractor shall not assign the rights and obligations arising from the Contract, in whole or in part, without prior written authorisation from the Commission.

II.8.2 In the absence of such authorisation, or in the event of failure to observe the terms thereof, assignment by the Contractor shall not be enforceable against and shall have no effect on the Commission.

ARTICLE II.9 - USE, DISTRIBUTION AND PUBLICATION OF INFORMATION ABOUT THE CONTRACT

II.9.1. The Contractor shall authorise the Commission to process, use, distribute and publish, for whatever purpose, by whatever means and on whatever medium, any data contained in the Contract, in particular the identity of the Contractor, the subject matter, the duration and the amount paid. Where personal data is concerned, Articles I.8 and II.5 shall apply.

II.9.2. Unless otherwise provided by the Special Conditions, the Commission shall not be required to distribute or publish documents or information supplied in performance of the Contract. If it decides not to distribute or publish the documents or information supplied,

the Contractor may not have them distributed or published elsewhere without prior written authorisation from the Commission.

II.9.3. Any distribution or publication of information relating to the Contract or use of outcome of the implementation of the Contract and provided as such by the Contractor shall require prior written authorisation from the Commission and, if so requested, shall mention that it was produced within a contract with the Commission. It shall state that the opinions expressed are those of the Contractor only and do not represent the Commission's official position.

II.9.4. The use of information obtained by the Contractor in the course of the Contract for purposes other than its performance shall be forbidden, unless the Commission has specifically given prior written authorisation to the contrary.

ARTICLE II.10– FORCE MAJEURE

II.10.1 Force majeure shall mean any unforeseeable and exceptional situation or event beyond the control of the contracting parties which prevents either of them from performing any of their obligations under the Contract, was not due to error or negligence on their part or on the part of a subcontractor and could not have been avoided by the exercise of due diligence. Defects in equipment or material or delays in making it available, labour disputes, strikes or financial problems cannot be invoked as force majeure unless they stem directly from a relevant case of force majeure.

II.10.2 Without prejudice to Article II.1.8 (e), if either contracting party is faced with force majeure, it shall notify the other party without delay by registered letter with acknowledgment of receipt or equivalent, stating the nature, likely duration and foreseeable effects.

II.10.3 Neither contracting party shall be held in breach of its contractual obligations if it has been prevented from performing them by force majeure. Where the Contractor is unable to perform his contractual obligations owing to force majeure, he shall have the right to remuneration for the supplies actually delivered and any service provided.

II.10.4 The contracting parties shall take the necessary measures to reduce damage to a minimum.

ARTICLE II.11 - LIQUIDATED DAMAGES

Should the Contractor fail to perform his obligations under the Contract within the time limits set by the Contract, then, without prejudice to the Contractor's actual or potential liability incurred in relation to the Contract or to the Commission's right to terminate the Contract, the Commission may decide to impose liquidated damages per calendar day of delay according to the following formula:

$$0.3 \times (V/d)$$

V is the amount specified in Article I.3.1;

d is the duration specified in Article I.2.3 expressed in days

The Contractor may submit arguments against this decision within thirty days of notification by registered letter with acknowledgment of receipt or equivalent. In the absence of reaction on his part or of written withdrawal by the Commission within thirty days of the receipt of such arguments, the decision imposing the liquidated damages shall become enforceable. These liquidated damages shall not be imposed where there is provision for interest for late completion. The Commission and the Contractor expressly acknowledge and agree that any sums payable under this article are in the nature of liquidated damages and not penalties, and represent a reasonable estimate of fair

compensation for the losses that may be reasonably anticipated from such failure to perform obligations.

ARTICLE II.12 – SUSPENSION OF THE CONTRACT

Without prejudice to the Commission's right to terminate the Contract, where the Contract is subject to substantial error, irregularity or fraud the Commission may suspend execution of the Contract or any part thereof. Suspension shall take effect on the day the Contractor receives notification by registered letter with acknowledgment of receipt or equivalent, or at a later date where the notification so provides. The Commission shall as soon as possible give notice to the Contractor to resume the execution suspended or inform that it is proceeding with contract termination. The Contractor shall not be entitled to claim compensation on account of suspension of the Contract or of part thereof.

ARTICLE II.13 – TERMINATION BY THE COMMISSION

II.13.1. The Commission may terminate the Contract in the following circumstances:

- (a) where the Contractor is being wound up, is having his affairs administered by the courts, has entered into an arrangement with creditors, has suspended business activities, is the subject of proceedings concerning those matters, or is in any analogous situation arising from a similar procedure provided for in national legislation or regulations;
- (b) where the Contractor has not fulfilled obligations relating to the payment of social security contributions or the payment of taxes in accordance with the legal provisions of the country in which he is established or with those of the country applicable to the Contract or those of the country where the Contract is to be performed;
- (c) where the Commission has evidence or seriously suspects the Contractor or any related entity or person, of professional misconduct;
- (d) where the Commission has evidence or seriously suspects the Contractor or any related entity or person, of fraud, corruption, involvement in a criminal organisation or any other illegal activity detrimental to the Community's or European Union's financial interests;
- (e) where the Commission has evidence or seriously suspects the Contractor or any related entity or person, of substantial errors, irregularities or fraud in the award procedure or the performance of the Contract;
- (f) where the Contractor is in breach of his obligations under Article II.3;
- (g) where the Contractor was guilty of misrepresentation in supplying the information required by the Commission as a condition of participation in the Contract procedure or failed to supply this information;
- (h) where a change in the Contractor's legal, financial, technical or organisational situation could, in the Commission's opinion, have a significant effect on the performance of the Contract;
- (i) where delivery of the supplies and execution of related tasks has not actually commenced within fifteen days of the date foreseen, and the new date proposed, if any, is considered unacceptable by the Commission;

- (j) where the Contractor is unable, through his own fault, to obtain any permit or licence required for performance of the Contract;
- (k) where the Contractor, after receiving formal notice in writing to comply, specifying the nature of the alleged failure, and after being given the opportunity to remedy the failure within a reasonable period following receipt of the formal notice, remains in serious breach of his contractual obligations.

II.13.2. In case of force majeure, notified in accordance with Article II.10, either contracting party may terminate the Contract, where performance thereof cannot be ensured for a quantity of supplies corresponding to at least one fifth of the quantity of supplies ordered.

II.13.3. Prior to termination under point c), d), e), h) or k), the Contractor shall be given the opportunity to submit his observations.

Termination shall take effect on the date on which a registered letter with acknowledgment of receipt terminating the Contract is received by the Contractor, or on any other date indicated in the letter of termination.

II.13.4. Consequences of termination

In the event of the Commission terminating the Contract in accordance with this article and without prejudice to any other measures provided for in the Contract, the Contractor shall waive any claim for consequential damages, including any loss of anticipated profits for uncompleted work. On receipt of the letter terminating the Contract, the Contractor shall take all appropriate measures to minimise costs, prevent damage, and cancel or reduce his commitments. He shall draw up the documents required by the Special Conditions for the supplies delivered and tasks executed up to the date on which termination takes effect, within a period not exceeding sixty days from that date.

The Commission may claim compensation for any damage suffered and recover any sums paid to the Contractor under the Contract.

On termination the Commission may engage any other contractor to deliver the supplies and execute the related services. The Commission shall be entitled to claim from the Contractor all extra costs incurred in doing so, without prejudice to any other rights or guarantees it has under the Contract.

ARTICLE II.13A – SUBSTANTIAL ERRORS, IRREGULARITIES AND FRAUD ATTRIBUTABLE TO THE CONTRACTOR

Where, after the award of the Contract, the award procedure or the performance of the Contract prove to have been subject to substantial errors, irregularities or fraud, and where such errors, irregularities or fraud are attributable to the Contractor, the Commission may refuse to make payments, may recover amounts already paid or may terminate all the contracts concluded with the Contractor, in proportion to the seriousness of the errors, irregularities or fraud.

ARTICLE II.14 – INVOICING AND PAYMENTS

II.14.1 Pre-financing guarantee:

Where required by Article I.4.1 or if the pre-financing is over €150 000, the Contractor shall provide a financial guarantee in the form of a bank guarantee or equivalent supplied by a bank or an authorised financial institution (“*the guarantor*”) equal to the amount indicated in the same article

to cover pre-financing under the Contract. Such guarantee may be replaced by a joint and several guarantee by a third party.

The guarantor shall pay to the Commission at its request an amount corresponding to payments made by it to the Contractor which have not yet been covered by equivalent delivery of supplies or execution of related services on his part.

The guarantor shall stand as first-call guarantor and shall not require the Commission to have recourse against the principal debtor (the Contractor).

The guarantee shall specify that it enters into force at the latest on the date on which the Contractor receives the pre-financing. The guarantee shall be retained until the pre-financing has been cleared against interim payments or payment of the balance to the Contractor. It shall be released the following month or, in the absence of such clearing, four months after the issuance of a corresponding debit note. The cost of providing such guarantee shall be borne by the Contractor.

II.14.2 Interim payments and payment of the balance:

Payments shall be executed only if the Contractor has fulfilled all his contractual obligations by the date on which the invoice is submitted.

At the end of each of the periods indicated in Annex II the Contractor shall submit to the Commission an invoice accompanied by the documents provided for in the Special Conditions.

If providing a progress report is a condition for payment, on receipt the Commission shall have the period of time indicated in the Special Conditions in which:

- to approve it, with or without comments or reservations, or suspend such period and request additional information; or
- to reject it and request a new progress report.

Approval of the progress report shall not imply recognition of the regularity or of the authenticity, completeness and correctness of the declarations and information it contains.

Where the Commission requests a new progress report because the one previously submitted has been rejected, this shall be submitted within the period of time indicated in the Special Conditions. The new progress report shall likewise be subject to the above provisions.

II.14.3 Payment currency and costs:

Payments are executed in the currency of the contract.

Costs of the transfer are borne in the following way:

- costs of dispatch charged by the bank of the Commission are borne by the Commission,
- cost of receipt charged by the bank of the Contractor are borne by the Contractor,
- all costs of repeated transfer caused by one of the parties are borne by the party who caused repetition of the transfer.

ARTICLE II.15 – GENERAL PROVISIONS CONCERNING PAYMENTS

II.15.1 Payments shall be deemed to have been made on the date on which the Commission's account is debited.

II.15.2 The payment periods referred to in Article I.4 may be suspended by the Commission at any time if it informs the Contractor that his invoice is not admissible, either because the amount is not due or because the necessary supporting documents have not been properly produced. The Commission may proceed with further verification, including an on-the-spot check, in order to ascertain, prior to payment, that the invoice is admissible.

The Commission shall notify the Contractor accordingly and set out the reasons for the suspension by registered letter with acknowledgment of receipt or equivalent. Suspension shall take effect from the date of dispatch of the letter. The remainder of the period referred to in Article I.4 shall begin to run again once the suspension has been lifted.

II.15.3 In the event of late payment the Contractor shall be entitled to interest, provided the calculated interest exceeds EUR 200. In case interest does not exceed EUR 200, the Contractor may claim interest within two months of receiving the payment. Interest shall be calculated at the rate applied by the European Central Bank to its most recent main refinancing operations ("*the reference rate*") plus seven percentage points ("*the margin*"). The reference rate in force on the first day of the month in which the payment is due shall apply. Such interest rate is published in the C series of the Official Journal of the European Union. Interest shall be payable for the period elapsing from the calendar day following expiry of the time limit for payment up to the day of payment. Suspension of payment by the Commission may not be deemed to constitute late payment.

ARTICLE II.16 – TAXATION

II.16.1 The Contractor shall have sole responsibility for compliance with the tax laws which apply to him. Failure to comply shall make the relevant invoices invalid.

II.16.2 The Contractor recognises that the Commission is, as a rule, exempt from all taxes and duties, including value added tax (VAT), pursuant to the provisions of Articles 3 and 4 of the Protocol on the Privileges and Immunities of the European Union.

II.16.3 The Contractor shall accordingly complete the necessary formalities with the relevant authorities to ensure that the supplies and services required for performance of the Contract are exempt from taxes and duties, including VAT.

II.16.4 Invoices presented by the Contractor shall indicate his place of taxation for VAT purposes and shall specify separately the amounts not including VAT and the amounts including VAT.

ARTICLE II.17 – RECOVERY

II.17.1 If total payments made exceed the amount actually due or if recovery is justified in accordance with the terms of the Contract, the Contractor shall reimburse the appropriate amount in euro on receipt of the debit note, in the manner and within the time limits set by the Commission.

II.17.2 In the event of failure to pay by the deadline specified in the debit note, the sum due shall bear interest at the rate indicated in Article II.15.3. Interest shall be payable from the calendar day following the due date up to the calendar day on which the debt is repaid in full.

II.17.3 The Commission may, after informing the Contractor, recover amounts established as certain, of a fixed amount and due by offsetting, in cases where the Contractor also has a

claim on the Union or the European Atomic Energy Community that is certain, of a fixed amount and due. The Commission may also claim against the guarantee, where provided for.

ARTICLE II.18 – CHECKS AND AUDITS

- II.18.1** Pursuant to Article 142 of the Financial Regulation applicable to the general budget of the European Communities, the Court of Auditors shall be empowered to audit the documents held by the natural or legal persons receiving payments from the budget of the Union from signature of the Contract up to five years after payment of the balance.
- II.18.2** The Commission or an outside body of its choice shall have the same rights as the Court of Auditors for the purpose of checks and audits limited to compliance with contractual obligations from signature of the Contract up to five years after payment of the balance.
- II.18.3** In addition, the European Anti-Fraud Office may carry out on-the-spot checks and inspections in accordance with Council Regulation (Euratom, EC) No 2185/96 and Parliament and Council Regulation (Euratom) No 1074/1999 from signature of the Contract up to five years after payment of the balance.

Annex II Tender Specifications (Invitation to Tender No ENER/D4/2012-104-3 of [*insert date*])

Annex III Contractor's Tender (No *[complete]* of *[insert date]*)