

Box 15a: Country of dispatch/export

The SAD Guidelines give more detailed information on some of the provisions and the codes included in Annexes 37 and 38 CCIP. To have their complete text please consult Annexes 37 and 38 CCIP.

15 C. disp./exp. code	
a	b

Completion of box 15a is obligatory for the following procedures:

1. release for free circulation;
2. placing under a customs procedure with an economic impact, such as inward processing (suspension system), temporary importation or processing under customs control;
3. computerised transit (NCTS).

Import procedures

If no stop or legal action unrelated to transport has occurred in an intermediate country, enter in box 15a the relevant Community code from Annex 38 for the country from which the goods were initially dispatched to the Member State of import. If such stops or action have occurred, the last intermediate country is to be considered the country of dispatch/export.

The country of dispatch/export means the country from which the goods were initially dispatched to the importing Member State, without any halt or legal operation not inherent in their transport having occurred in an intermediate country (Article 7(1)(b) of Regulation (EC) 1917/2000).

A halt is any temporary interruption of the physical movement of the goods before continuing the movement to the final destination.

A legal operation can be any commercial transaction or comparable operation covered by legislation (e.g. sale or processing under contract).

An intermediate country is every country en route – except the countries of dispatch and destination (a third country or a Member State). A halt or legal operation in the country of destination does not lead to any change in the country of dispatch/export.

Halts or legal operations related to (inherent in) transport of the goods include, for instance, a change of means of transport, preserving operations to keep the goods in good condition during transport, breaking-up and assembly of packages and temporary storage.

The relevant country codes are published regularly in the Official Journal of the European Union based on Council Regulation (EC) No 1172/95 of 22 May 1995, and in particular Article 9 thereof. The coding of countries and territories is based on the ISO alpha standard 2 in force as far as it is compatible with the requirements of Community legislation. For a full list of the country codes, see the regularly updated legislation on the nomenclature of countries and territories for the external trade statistics of the Community and statistics of trade between Member States, which is available on the [GEONOM](#) website.

Examples

The country of dispatch/export of imports is based on the country of consignment, as defined in Article 7(1)(b) of Regulation (EC) 1917/2000, and must be entered in box 15a of the SAD.

Last update: July 2008

Direct placing under the inward processing procedure suspension (IPS) system in Greece:

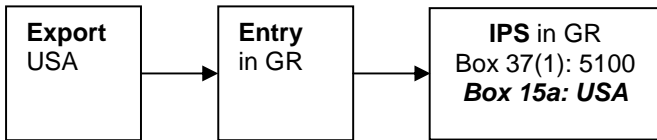

Importation for free circulation (FC) in the Netherlands after the transit procedure (TP) in the Netherlands:

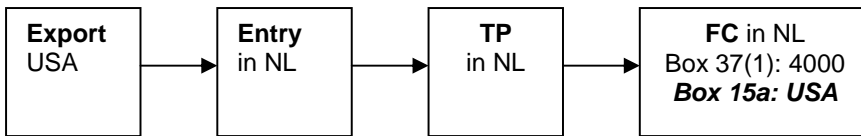

Importation for free circulation (FC) in the Netherlands after the transit procedure (TP) from Germany into the Netherlands:

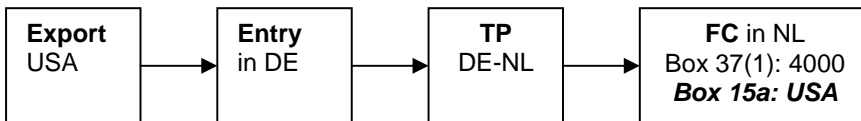

Placing under the inward processing procedure drawback (IPD) system in the Netherlands after a customs warehouse (CW) procedure other than for the purpose of re-arranging transit in the Netherlands:

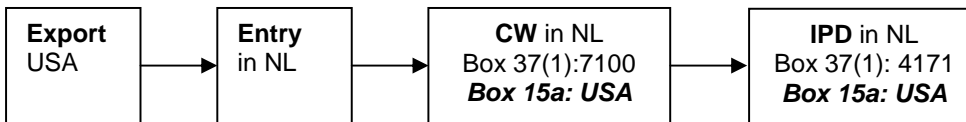

Importation for free circulation (FC) in the Netherlands after a customs warehouse (CW) procedure other than for the purpose of re-arranging transit in France and transit procedure (TP) from France into the Netherlands:

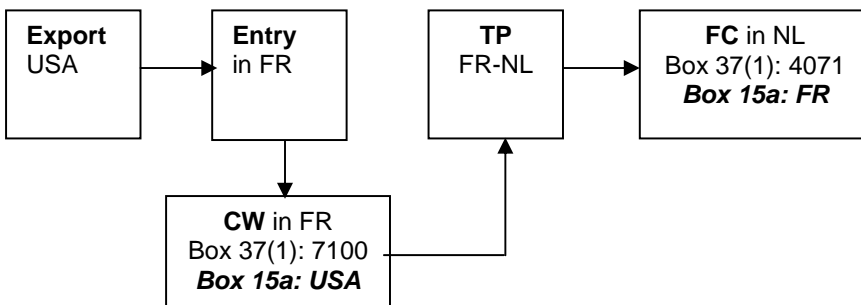

Last update: July 2008

Importation for free circulation (FC) in the Netherlands after the inward processing procedure suspension (IPS) system in Slovakia and the transit procedure (TP) from Slovakia into the Netherlands:

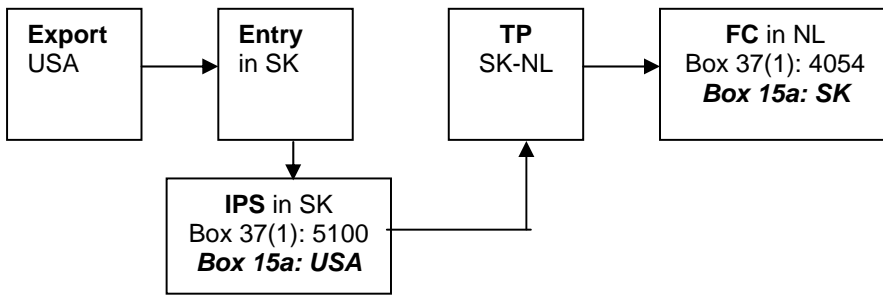

Importation for free circulation (FC) in the Netherlands after processing under the customs control procedure (PCC) in Greece and the transit procedure (TP) from Greece into the Netherlands:

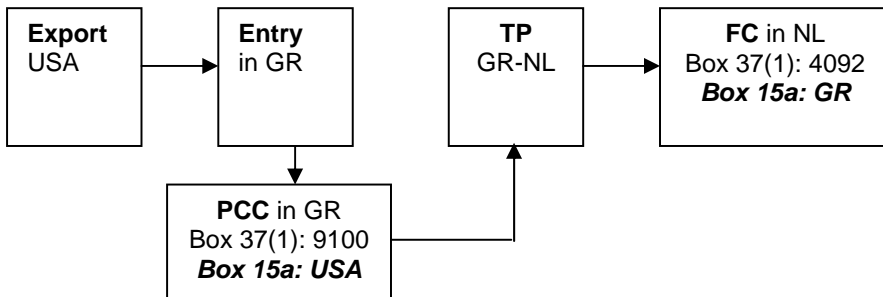

Importation for free circulation (FC) in the Netherlands after the customs warehouse (CW) procedure other than for the purpose of re-arranging transit in Sweden, the transit procedure (TP) from Sweden into Latvia, the inward processing procedure suspension (IPS) system in Latvia and the transit procedure (TP) from Latvia into the Netherlands:

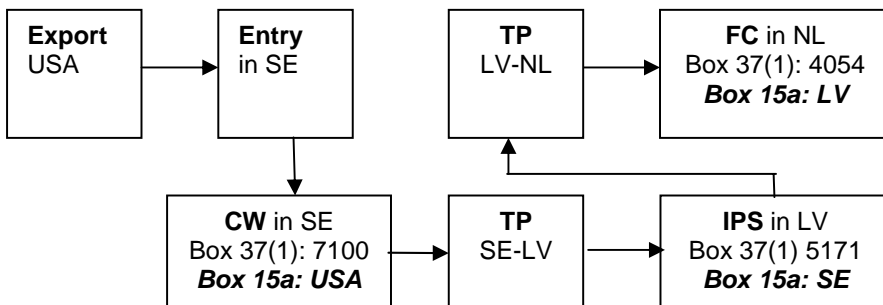

Importation for free circulation (FC) in the Netherlands after temporary import (TI) in Lithuania, the transit procedure (TP) from Lithuania into Estonia, the customs warehouse procedure only for the purpose of re-arranging transit (CWT) in Estonia and the transit procedure (TP) from Estonia into the Netherlands:

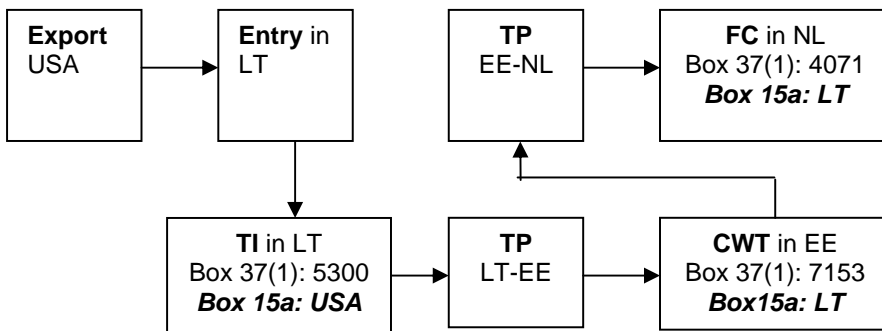

Export procedures

This box is optional. Member States can choose whether to fill it in or not.

Examples

Permanent export from Finland to Norway, via Sweden: The goods are transported from Finland to Sweden by lorry and ferry and then on to Norway by lorry.

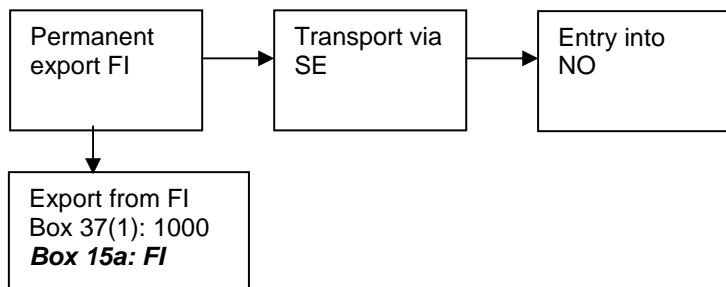

Permanent export from Sweden to the USA: The goods are transported from Sweden to the Netherlands by truck and reloaded onto a ship for transport to the USA.

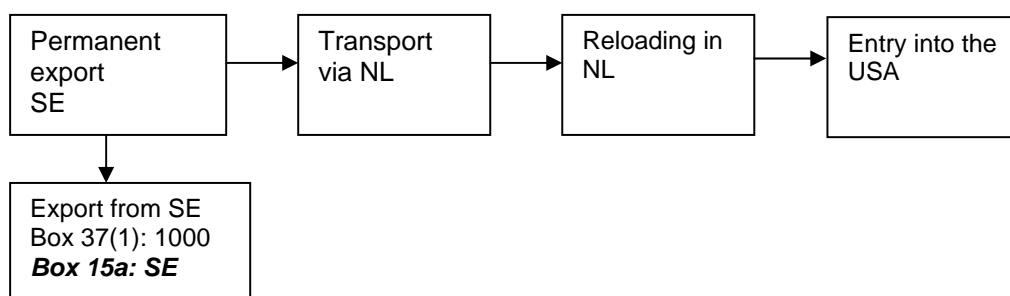

Re-export from Germany to the USA after the inward processing procedure suspension system: The goods are transported by rail to Rotterdam for onward transport by ship to the USA.

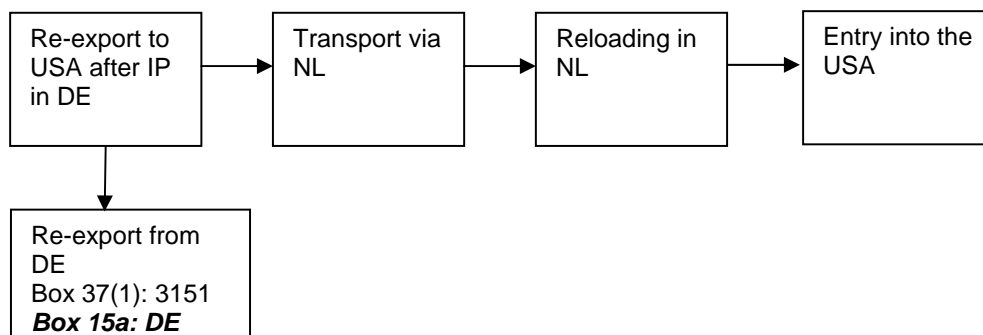

Last update: July 2008

An Italian company sends goods to Greece for an exhibition. The goods are sold to a buyer in Turkey. An export declaration is made in Greece on behalf of the Italian exporter.

