

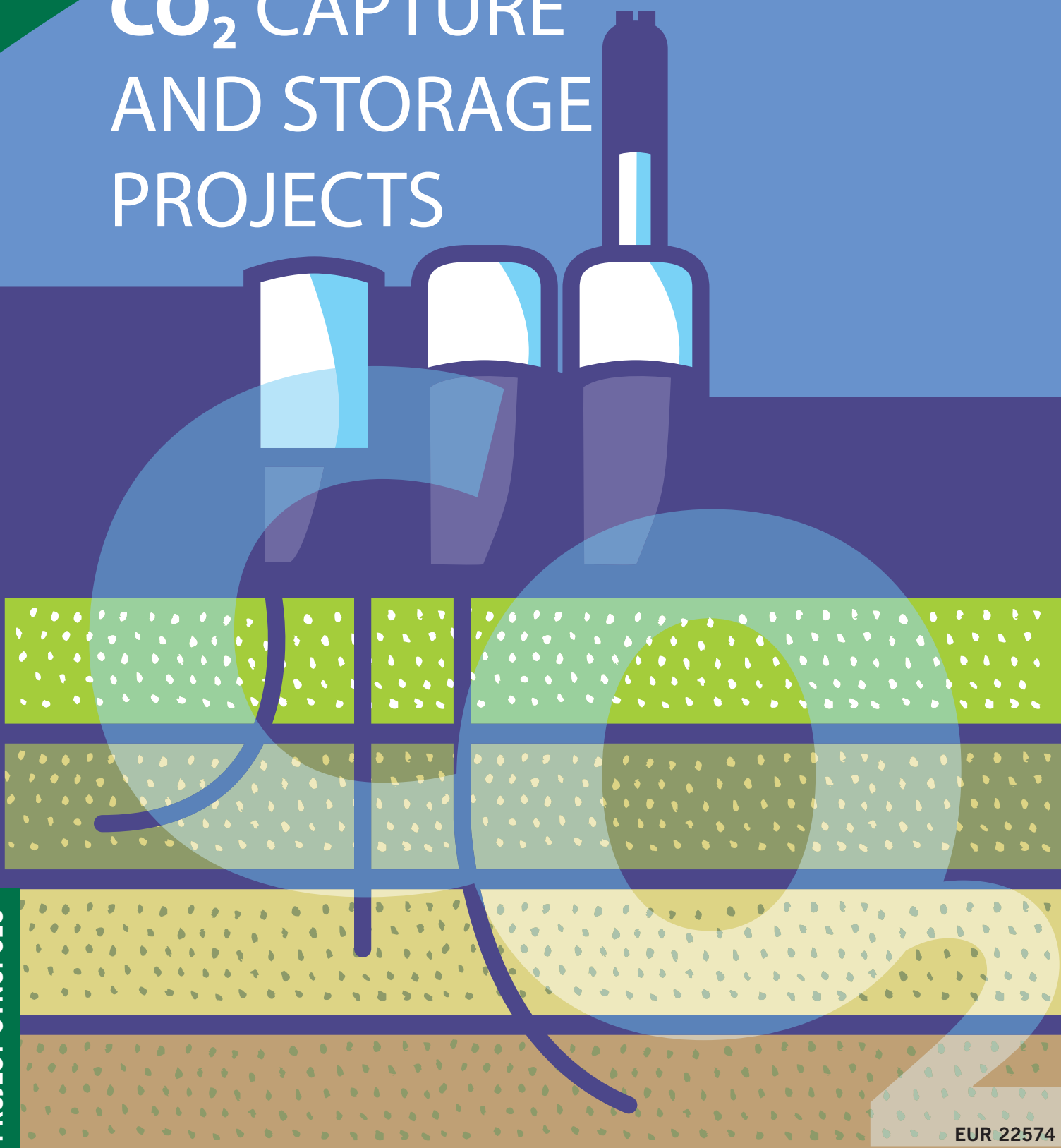

CO₂ CAPTURE AND STORAGE PROJECTS



Interested in European research?

Research*eu is our monthly magazine keeping you in touch with main developments (results, programmes, events, etc.). It is available in English, French, German and Spanish. A free sample copy or free subscription can be obtained from:

European Commission
Directorate-General for Research
Communication Unit
B-1049 Brussels
Fax (32-2) 29-58220
E-mail: research-eu@ec.europa.eu
Internet: <http://ec.europa.eu/research/research-eu>

EUROPEAN COMMISSION

Directorate-General for Research
Directorate Energy
Contact: Pierre Dechamps
Email: pierre.dechamps@ec.europa.eu
Helpdesk: rtd-energy@ec.europa.eu
Internet: <http://ec.europa.eu/research/energy/>

CO₂ CAPTURE AND STORAGE PROJECTS

Europe Direct is a service to help you find answers
to your questions about the European Union

Freephone number (*):

00 800 6 7 8 9 10 11

(*) Certain mobile telephone operators do not allow access to 00 800 numbers
or these calls may be billed.

LEGAL NOTICE

Neither the European Commission nor any person acting on behalf of the Commission is responsible for the use which might be made of the following information.

The views expressed in this publication are the sole responsibility of the author and do not necessarily reflect the views of the European Commission.

A great deal of additional information on the European Union is available on the Internet.
It can be accessed through the Europa server (<http://ec.europa.eu>).

Cataloguing data can be found at the end of this publication.

Luxembourg: Office for Official Publications of the European Communities, 2007

ISBN 92-79-03724-2

ISSN 1018-5593

© European Communities, 2007

Reproduction is authorised provided the source is acknowledged.

Printed in Belgium

PRINTED ON WHITE CHLORINE-FREE PAPER

TABLE OF CONTENTS

FOREWORD	4
■ CO₂ CAPTURE PROJECTS	7
CO ₂ from Capture to Storage – CASTOR	8
Enhanced Capture of CO ₂ – ENCAP	10
Carbon Dioxide Capture and Hydrogen Production from Gaseous Fuels – CACHET	12
Towards Hydrogen Production with CO ₂ Management – DYNAMIS	14
■ ADVANCED CO₂ SEPARATION PROJECTS	17
Innovative in situ CO ₂ Capture Technology for Solid Fuel Gasification – ISCC	18
Calcium Cycle for Efficient and Low-cost CO ₂ Capture using Fluidised Bed Systems – C3-CAPTURE	20
Chemical Looping Combustion CO ₂ -Ready Gas Power – CLC-GAS POWER	22
Advanced Separation and Storage of Carbon Dioxide: Design, Synthesis and Applications of Novel Nanoporous Sorbents – DESANNS	24
Hybrid Hydrogen – Carbon Dioxide Separation Systems – HY ₂ SEPS	26
■ CO₂ STORAGE PROJECTS	29
In situ R&D Laboratory for Geological Storage of CO ₂ – CO ₂ SINK	30
Network of Excellence on Geological Sequestration of CO ₂ – CO ₂ GEONET	32
Monitoring and Verification of CO ₂ Storage and ECBM in Poland – MOVECBM	34
CO ₂ Geological Storage: Research into Monitoring and Verification Technology – CO ₂ REMOVE	36
Assessing European Capacity for Geological Storage of Carbon Dioxide – EU GEOCAPACITY	38
CO ₂ Capture and Storage Networking Extension to New Member States – CO ₂ NET-EAST	40
■ PROJECTS WITH A SUBSTANTIAL INTERNATIONAL DIMENSION	43
CO ₂ Capture Using Amine Processes: International Cooperation and Exchange – CAPRICE	44
Cooperation Action with CCS – China-EU – COACH	46
International Cooperation Actions on CO ₂ Capture and Storage – INCA-CO ₂	48
LIST OF COUNTRY CODES	51

FOREWORD

There is now scientific consensus that human activities, and in particular the way we transform and use fossil fuel energy, are responsible for increased CO₂ concentrations in the atmosphere and climate change. The work done by the IPCC (International Panel on Climate Change) of the UNFCCC (United Nation Framework Convention on Climate Change) has been instrumental in building this consensus.

There is also growing evidence that the CO₂ concentration in the atmosphere which would enable us to limit the negative effects of climate change to something acceptable, for instance, to limit the average temperature increase to less than 2°C -the EU objective-, will not be achieved with current policies in place. From an energy supply point of view, this translates into saying that renewable energy sources, which are essentially carbon-free, will not be deployed quickly enough.

An important point, highlighted by the Stern Report, is that the costs of adaptation to climate change will be at least an order of magnitude larger than the costs of mitigating climate change. This is a clear call for immediate action.

Given the problems created by the build up of CO₂ in the atmosphere, and that CO₂-free energy sources cannot be deployed quickly enough, transition technologies are needed. CO₂ capture and storage is such a transition technology. It will allow the use of fossil fuels, in particular coal, in a way which is compatible with a sustainable environment.

Coal is abundant and will very likely be used where it is available at competitive prices. Estimated reserves of conventional oil and gas amount to approximately 300 Gtons of carbon, which, if released instantaneously in the atmosphere would roughly double the present CO₂ concentration, which is already 30 to 40% above the pre-industrial average. In contrast, the estimated coal resources contain approximately 3000 Gtons of carbon, or 10 times conventional oil and gas. Unlike oil and gas, coal reserves are reasonably well distributed throughout the world, with vast amounts available both in developed economies, like in the US, and in developing economies, like in China and India.

It is against this background that research activities in CO₂ capture and storage have become a priority topic in energy research in the Framework Programmes for Research and Technological Development of the EU. Two main objectives are addressed.

For CO₂ capture, the challenge is to separate CO or CO₂ from synthetic fuels derived from fossil fuels, or to separate CO₂ from the flue gas. This is respectively pre- and post-combustion capture. There are also alternative ways, like for instance having the combustion in almost pure oxygen (oxyfuel combustion), which produces a stream of highly concentrated CO₂, but requires the separation of oxygen from the air.

The necessary separation processes, based on solvents, membranes, cryogenic technologies or other chemical or physical processes exist, and are already applied in industry, for instance in the petrochemical industry to increase the yield in the lighter fractions in oil distillation, or in the food industry, to produce CO₂ for the fuzzy drinks.

The challenges are to decrease the cost of capture and to scale-up the technologies to the size required to address large scale power generation and make it almost CO₂ free. From the point of view of size, a large coal plant of 1000 MW will typically generate about 8000 tons of CO₂ per day or about 3 million tons per year if it is running at base load. This is more than one order of magnitude larger than existing separation technologies. From the point of view of costs, the current technologies, if applied, would cost anywhere between 20 and 50 € per ton of CO₂ separated, which translates for a large coal plant into an increase in the cost of the electricity produced of about 30% on average.

Fossil fuel based power generation with CO₂ capture and storage will be competitive in a mix of low CO₂ emitting technologies if these costs are properly addressed and reduced, both in their capital expenditure and operational expenditure dimensions. Another reason to address the operational expenditure dimension is that, in reality, most of it is the cost of increased fossil fuel consumption, because of the efficiency penalty when CO₂ capture is applied.

For storage, the major challenge is to ascertain the safety and reliability of storage of CO₂ in geological formations at all timescales.

Only geological storage of CO₂ is considered to be environmentally acceptable in the EU. Ocean storage above the seabed, for instance, is not considered acceptable. Several geological settings are envisaged as potential storage sites, oil and gas reservoirs, in exploitation or depleted, non mineable coal seams, and deep saline aquifers. In all cases, the CO₂ should be under a hydrostatic pressure of more than 70 bars (that is deeper than 700 meters on-shore) to make sure that it is stored as a supercritical fluid, and not as a gas. From a storage potential point of view, estimates – also obtained in Framework Programme research contracts – are that deep saline aquifers have the potential to hold more than all of the CO₂ which would be produced if we used all of the oil, gas and coal. These geological formations are – like coal reserves – quite evenly spread across the world.

The challenge is therefore to make sure that the injection of CO₂ in these strata is a safe process, from the immediate health and safety issues associated with the injection process, to the CO₂ storage permanence required to effectively address climate change. From this point of view, CO₂ injection and storage, like any other engineering activity, will require a proper legislative and regulatory framework, norms and standards, good practice, and common sense. Mother Nature, which has stored oil, gas, water and CO₂ for million years, indicates that this should be feasible.

Certification processes and a proper accounting system will also be required in order to allow the stored CO₂ to be counted against national CO₂ emissions in the context of a CO₂ trading scheme for instance.

The health and safety aspects are also directly related to the public acceptance of the technology. An inadequate public awareness or worse, an inadequate safety level, will surely translate into a new Not I My Back Yard (NIMBY) reaction.

Safety is also directly linked to the long term liability issue. The timescales required to effectively combat climate change are incompatible with the operations of a private company, so that liability transfer to the public authorities must take place sometime after the end of the injection. This can happen only if proper site certification, monitoring and verification methods are in place.

The projects listed in this brochure, which were all funded under the 6th Framework Programme for Research and Technological Development of the EU address these problems, each in their own way. They represent a research and development effort of the order of 150 million €, of which about 70 million € is public money.

The period of FP6, 2002-2006, also saw the emergence of the Zero Emission Technology Platform, which will be instrumental in providing more coherence to the actions carried out under the 7th Framework Programme and beyond, at all levels, research portfolio, coordination with the Member States and international.

Further to the research policy, there are also recent development from an energy policy point of view, with a "Energy Package" of Commission Communications, published in early 2007, most of the recommendations of which have been taken on board by the Council. This Communication was advocating that all fossil fuel power plants built from now on should be capture-ready, and all fossil fuel power plants built after 2020 should be equipped with capture and storage.

This will allow the EU to be in a dominant position internationally for the large scale deployment of zero emission fossil fuel based technologies worldwide. It is a pre-requisite for the three pillars of energy policy – sustainability, security of supply and competitiveness – to be reconciled and fulfilled.



CO₂ CAPTURE PROJECTS



CO₂ from capture to storage

CASTOR

Objectives

The project's objective is to make possible the capture and geological storage of 10% of European CO₂ emissions, or 30% of the emissions of large industrial facilities (mainly conventional power stations). To accomplish this, two types of approach must be validated and developed: new technologies for the capture and separation of CO₂ from flue gases and its geological storage, and tools and methods to quantify and minimise the uncertainties and risks linked to the storage of CO₂. In this context, the CASTOR project is aimed more specifically at reducing the costs of capture and separation of CO₂ (from € 0-60/tonne to € 20-30/tonne CO₂), improving the performance, safety, and environmental impact of geological storage concepts and, finally, validating the concept at actual sites.

The R&D work is divided into three sub-projects:

- post-combustion capture (65% of the budget)
- geological storage (25% of the budget)
- strategy for CO₂ reduction (10% of the budget).

Key Issues

Work on capture is aimed at developing new CO₂ post-combustion separation processes suited to the problems of capture of CO₂ at low concentrations in large volumes of gases at low pressure. The processes will be tested in a pilot unit capable of treating from 1-2 tonnes of CO₂ per hour from real fumes. This pilot will be implemented in the Esbjerg power station, operated by Elsam in Denmark.

The objectives of work on post-combustion capture are:

- development of absorption liquids, with a thermal energy consumption of 2.0 GJ/tonne CO₂ at 90% recovery rates;
- resulting costs per tonne CO₂ avoided, not higher than 20-30 €/tonne CO₂, depending on the type of fuel;
- pilot plant tests showing the reliability and efficiency of the post-combustion capture process.

The work on storage will provide the European industrial community with four new storage facility case studies representative of the geological variety of existing sites across Europe:

- storage in an abandoned reservoir in the Mediterranean (Casablanca field, operated by Repsol, Spain);
- storage in a deep saline aquifer (Snøhvit, North Sea, operated by Statoil, Norway, injection in 2006);
- storage in two depleted gas reservoirs, one deep, 2 500 m down (K12b, North Sea, Netherlands, operated by Gaz de France, injection in 2004), and the other closer to the surface and on land, 500 m down (Lindach, Austria, operated by Rohöl).

Risk and environmental impact studies will be conducted and methodologies for predicting the future of these sites and for monitoring them will be developed, thereby enriching current knowledge in these fields. During the time-line of the CASTOR project, CO₂ injection will be performed in at least two sites: K12b and Snøhvit.

The activity under "Strategy for CO₂ reduction" aims to define the overall strategies required to effect a 10% reduction of EU CO₂ emissions and to regularly monitor the effectiveness of the strategies (from capture to storage) from a techno-economical point of view. Research work is also focused on obtaining data on sources and potential geological storage capacities from Eastern Europe (extension of GESTCO European project).



Expected Impact

CASTOR will yield major impacts in at least three areas:

- it will make energy systems cleaner. A reduction of 10% Europe-wide is achievable by reducing emissions to near zero for about 30% of European fossil-fuel power plants (in 2010). It will thereby help to reach internationally agreed emission targets. CASTOR will also facilitate a more general move towards hydrogen energy systems, for which capture and storage technology is also required for environmental reasons. CASTOR will further assist the smooth transition to an energy system based predominantly on renewables, thereby reducing the likely adverse economic impacts of a rapid system transfer. As a consequence, CASTOR can make key contributions to the solution of major environmental, economic and societal problems;
- it will also contribute to European security of supply – in this way it will be possible to continue using coal-fired plants as carbon-low infrastructure for energy. The present market position of European research and industry in the fields of capture and underground storage of CO₂ needs to be further developed, strengthened and exploited. These market segments are expected to gain substantial importance in the medium- to long-term future. Application of such technologies will probably become a requirement for new industrial energy installations and, with CO₂ trading, also for existing power plants based on fossil fuels. We foresee that by reinforcing the competitiveness of European players in this market segment, a world market share of perhaps 80% in this field can be achieved. This will only be possible by active participation in technological innovation and development. Exploitation of CASTOR results and products is guaranteed by the active participation of industrial partners.



The United States has just announced FutureGen, a US\$ 1 billion investment to develop technologies for joint power and hydrogen production, combined with CO₂ capture, to maintain coal as a fuel for the future. The USA has not signed the Kyoto Protocol, and will probably aim at the European market. A large integrated research effort is needed to counterbalance this – this is what CASTOR is all about.

INFORMATION

Contract number
502586

Instrument
Integrated Project

Total cost
€ 15.8 million

EC funding
€ 8.5 million

Coordinator
Pierre Le Thiez
Institut Français du Pétrole - FR
pierre.le-thiez@ifp.fr

Partners
Alstom Power Centrales - FR
BASF - DE
Bundesanstalt für Geowissenschaften und Rohstoffe - DE
Bureau de Recherches Géologiques et Minières - FR
Elsam - DK
ENERGI E2 - DK
Enil Technologie - IT
Gaz de France - FR
Geological Survey of Denmark and Greenland - DK
GVS - IT
Imperial College of Science, Technology and Medicine - UK
Istituto Nazionale di Oceanografia e di Geofisica Sperimentale - IT
Mitsui Babcock Energy Limited - UK
Natural Environment Research Council - UK
Netherlands Organisation for Applied Scientific Research - NL
Norwegian University of Science and Technology - NO
Powergen/E.ON Engineering - UK
Public Power Corporation - EL
Repsol Investigaciones Petrolíferas - ES
Rohöl Aufsuchungs - AT
RWE Power - DE
Siemens - DE
SINTEF – Energy Research - NO
SINTEF – Stiftelsen for Industriell og Teknisk Forskning ved Norges Tekniske Høgskole - NO
SINTEF Petroleumsforskning - NO
Statoil - NO
Universität Stuttgart - DE
Universiteit Twente - NL
Vattenfall - SE

Website
www.co2-castor.com

Enhanced capture of CO₂

ENCAP

Objectives

The stated target of ENCAP is to provide pre-combustion decarbonisation technologies in power cycles for large power plants operated by natural gas, residue oil, hard coal and lignite with the objective of achieving:

- at least 90% capture rate for CO₂;
- 50% capture cost reduction – from a current level of € 50-60 per tonne of CO₂ captured, covering technical validation including all steps of research of selected prospective concepts with economical assessment and HSE-conformance – with links to transportation and storage.

The scientific objective is to generate new knowledge and comprehension of systems, processes, materials and matter by characteristics of potentiality, constraints and governing mechanisms pertaining to pre-combustion decarbonisation of fossil fuels, with a bearing on solutions that (might) facilitate sequestering of CO₂. This objective requires targeted fundamental and applied research, and topical involvement by leading European R&D institutions.

The objectives will be achieved by the selection of at least one candidate technology concept – provided sufficiently high potentiality is attributed, so that it can be developed up to a level that is required and sufficient to ensure viability. Methodology for the ranking of concepts will be developed including cost assessment and validation of critical elements.

Key Issues

The research activities of the project are structured within six subprojects that directly meet the project objectives:

SP1 Process and Power Systems

Aimed at techno-economic impact-and-feasibility assessment of options, with recommendations for subsequent demonstration and scale-up.

SP2 Pre-combustion Decarbonisation Technologies

Research on new technological features of added CO₂-capture-related components – emphasising cryogenic technology for oxygen production.

SP3 OxyFuel Boiler Technologies

The use of oxygen/recycled carbon dioxide in large boilers constitutes a new area for research and verification in fundamental and larger-scale testing.

The concepts initially developed will use cryogenic technology for oxygen production.

SP4 Chemical Looping Combustion

Emphasising cyclic materials, reactors, and operational aspects.

SP5 High-temperature Oxygen Generation for Power Cycles

One obstacle of pre-combustion decarbonisa-

tion in large-scale oxy-fuel (boiler) power generation is the energy penalty associated with current cryogenic technology. Therefore, new non-cryogenic oxygen production technologies are needed that could offer significant improvements to the power cycle efficiency.

Research on new promising low-cost oxygen production technologies – emphasising non-cryogenic technology for oxygen production.

SP6 Novel Pre-combustion Capture Concepts

Addressing new concepts and required knowledge that is needed and required in order to make relevant decisions for pilot tests.

Technical Approach

To meet the objectives of ENCAP, critical scientific actions must be undertaken and resolved – including:

- assessment studies of materials and cycle working media, in relation to emerging concepts, to determine the potentiality and impacts of candidate materials on performance and the cost of actual capture concepts, including criteria for materials selection and testing conditions;
- research on absorbents and permeable membranes (polymeric and ceramic) having a



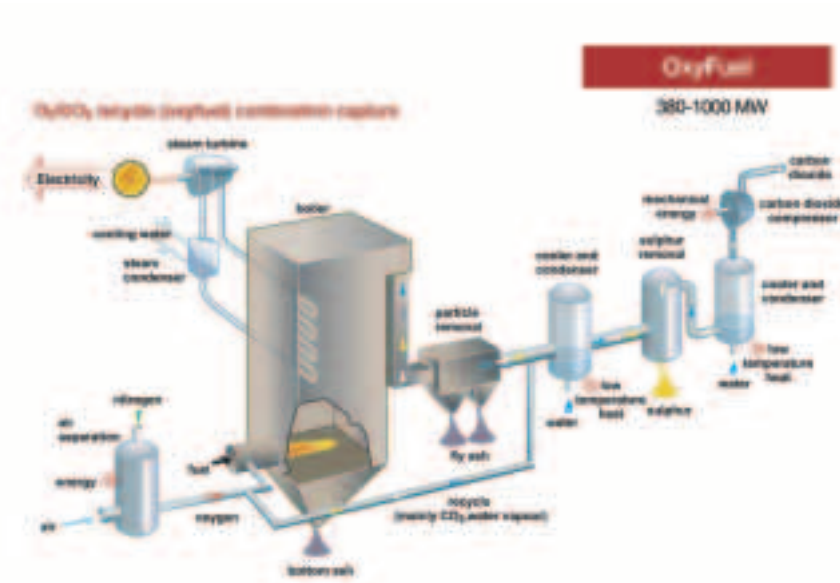

INFORMATION

Contract number
502666

Instrument
Integrated Project

Total cost
€ 22.2 million

EC funding
€ 10.702 million

Coordinator
Leif Brandels
Vattenfall AB - SE
Leif.Brandels@vattenfall.com

Partners
Air Liquide - FR
Alstom Switzerland - CH
Alstom Power Boiler - DE
Alstom Power Boilers - FR
Alstom Power Centrales - FR
Alstom Power - UK
BOC - UK
Centre for Research and Technology Hellas - EL
Chalmers Tekniska Högskola - SE
Deutsches Zentrum für Luft- und Raumfahrt - DE
ENERGI E2 A/S* - DK
Institut Français du Pétrole - FR
Linde - DE
mg engineering Lurgi Oel Gas Chemie - DE
Mitsui Babcock Energy - UK
Netherlands Organisation for Applied Scientific Research - NL
Public Power Corporation - EL
RWE Power - DE
Siemens - DE
SINTEF Energiforskning - NO
SINTEF Stiftelsen for industriell og teknisk forskning ved Norges Tekniske Högskole - NO
Statoil ASA - NO
Norges Teknisk-Naturvitenskapelige Universitet - NO
Universität-Gesamthochschule Paderborn - DE
Universität Stuttgart - DE
Universiteit Twente - NL
University of Ulster - UK

Website
www.encapco2.org

*until 2006-06-30

significant impact on large-scale absorption and separation of selected gas fractions;

- research and qualification of oxygen carriers and oxygen transport dense ceramic membranes to facilitate oxygen production – including methods and materials for high-temperature oxygen generation, utilising either oxygen transport ceramic membranes or ceramic autothermal recovery processing (CAR) – especially perovskite materials aimed at a cost reduction of 40% and efficiency improvement of 40%, as compared to the state-of-the-art;
- high-temperature heat exchangers in boilers, and materials for vapour and CO₂-enriched atmospheres, in order to withstand the high temperatures resulting from the combustion of fossil fuels in denitrogenised air, and parts exposed to high-temperature-reducing atmosphere, including innovative combustion schemes aimed at increasing the content from 30% to almost 100% hydrogen in gas turbines;
- thermo-fluid-reactive modelling of oxygen carriers that includes heat-and-mass balancing models for oxygen carriers required for the

determination of the relationship between the performance-stability of oxygen-adsorption and membrane materials at relevant conditions in order to achieve the objectives of ENCAP;

- identification of technical and economic barriers that might reduce the performance and increase the cost of actual concepts.

Expected Impact

- performing research and development on pre-combustion CO₂ capture and validating it by testing the technical and economic feasibility of concepts, and also interacting with research-related networks and carrying out training and dissemination;
- ENCAP will generate knowledge and results that enable power companies to launch a new design project by 2008- 2010 aimed at a large-scale demonstration plant;
- enhancing the competitiveness of European industry;
- contributing to the creation of a European Research Area for CO₂ capture.

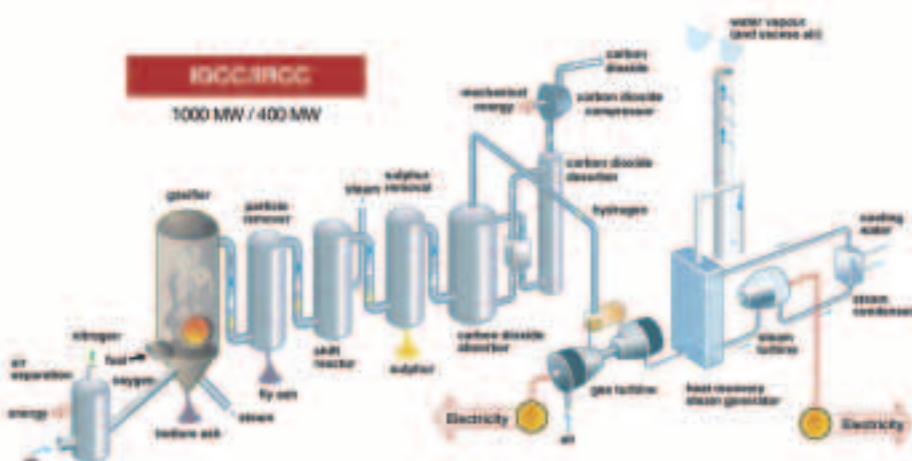



Carbon Dioxide Capture and Hydrogen Production from Gaseous Fuels

CACHET

Objectives

The overall goal is to develop innovative technologies which will substantially reduce the cost of CO₂ capture, whilst simultaneously producing H₂ from natural gas fuel. Several promising technologies already identified as having the potential to significantly reduce the cost of CO₂ capture will be further developed and evaluated. The intent is that the technology will be ready for pilot-scale testing from 2009 and then subsequent pre-commercial demonstrations and readiness for full-scale commercialisation is expected around 2015.

CACHET will focus on developing technologies for use with gaseous fuels, principally natural gas, although some will also be adaptable for use with syngas derived from solid fuels. Most other existing international and EU FP6 CO₂ capture R&D is focused on solid fuels, so CACHET will be the leading international R&D programme targeting CO₂ capture from gaseous fuels, positioning Europe to be the world leader in this area which is identified as a priority in the call. The technologies developed in CACHET will be applicable to CO₂ in the power generation sector, where substantial cost reductions will be available to zero-emissions fossil-fuelled CCGT power plants. The technologies will also bring improved economics to industrial processes such as crude oil refining which use H₂ on a large scale.

Technical Approach

The overall goal of the CACHET project is to develop innovative technologies which will substantially reduce the cost of CO₂ capture whilst simultaneously producing H₂ from natural gas fuel. Existing CO₂ capture costs are in the range 50-60 €/te and CACHET will target a substantial reduction to 20-30 €/te with 90% capture rate and CO₂ delivered at pipeline pressure for disposal.

Specific objectives may be summarised as follows:

- define a technical and economic base-case for technology evaluation;
 - apply systematic design methodology to each of the technologies, with the intention of identifying optimised process designs for technologies both individually and also technical and economic synergies arising through innovative combinations of technologies;
 - complete a rigorous risk-based technical and economic evaluation of the technologies;
 - recommend for pilot the preferred technology, or a combination of preferred technologies, or key element(s) of the preferred technology;
 - evaluate the health, safety and environmental impact of deployment of the technology;
 - protect the intellectual property generated by the project and disseminate the results according to agreed documented plans;
 - evaluate the results produced by the R&D effort, confirm that the overall goal of the CACHET project has been met and provide the necessary performance data to allow scale-up to a pilot plant.
- progress the development of four distinct candidate technology areas to proof of concept, with each area containing a number of leading-edge technologies;
 - conduct a review of relevant published literature world-wide and conduct screening evaluations of any promising technologies that might impact on the CACHET project;
 - gather sufficient technical and cost data from the technologies to feed-in to a consistent evaluation;

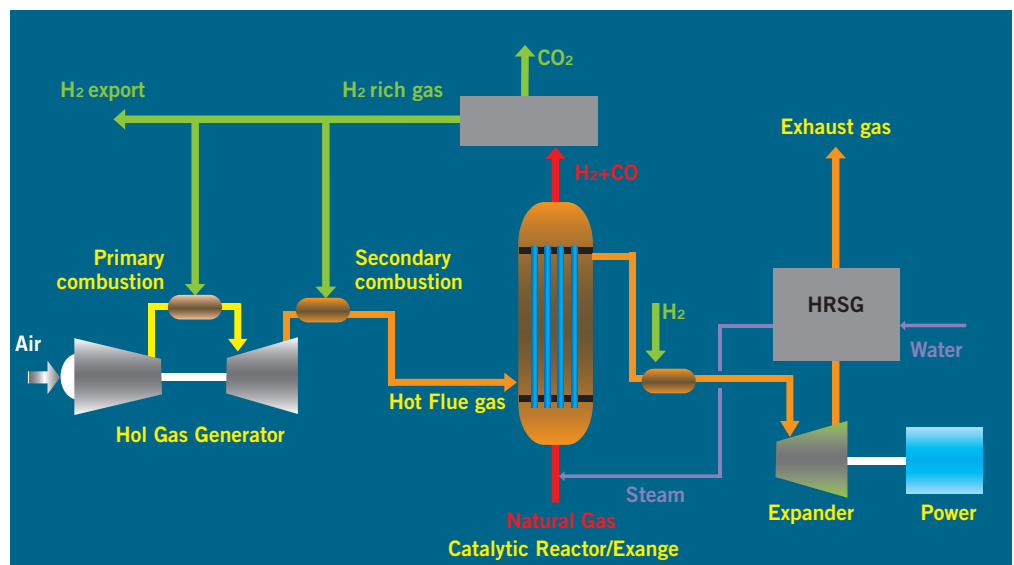

SP1-WP1: Hygensys: the process concept

Pre-combustion capture is the only approach for conversion of gaseous fuels to H₂ while capturing CO₂. The energy industry-sponsored CO₂ Capture Programme (CCP) has identified numerous technology options in this field. Following a four-year period of extensive assessment, the CCP project selected several innovative technologies exhibiting high-potential efficient H₂ production with CO₂ capture, and which meet EU cost targets of € 20-30 per tonne for CO₂ capture.

The most promising technologies are 'Hygensys' (advanced steam methane reforming), Redox Technologies ('One-Step Reforming', and 'Chemical Looping Reforming'), 'Hydrogen Membrane Reactors for Natural Gas Reforming and Water Gas Shift', and 'Sorption-Enhanced Water Gas Shift'. All of the selected technologies are still in the development phase. In each case research has confirmed the feasibility of the processes. Further development is needed to generate sufficient technical performance and cost data to perform an economic assessment and technology risk analysis of a large-scale plant before the most promising technology can be selected for pilot-plant scale assessment.

Expected Impact

The CACHET programme meets the European strategic and policy objectives of research into sustainable energy systems, particularly in the area of reducing greenhouse gases associated with continued use of fossil fuels. It is based on the use of natural gas fuel, which will form an increasing proportion of European fossil fuel demand in the future. The proposal will develop and reduce the cost of technologies to enable deep reductions (ca 90%) in greenhouse gas CO₂ emissions associated with H₂ production from natural gas fuel for use in power, industry and H₂ production. The technology developed in this project will make a material contribution to this key deliverable of the sustainable energy thematic area, namely that of reducing greenhouse gas emission levels in future. It is also important as an enabling process in the transition to the H₂-based economy of the future.

CO₂ capture and storage is not expected to be commercially deployed until ca 2015, and the technology developed in this programme will be available in this timeframe. Thus the potential impacts on European and global emissions from these technologies will occur in the medium to



WP4 testing and development rig under operation



Ed van Selow and Paul Verbraeken, ECN, review the results and monitor rig performance

long term. This will contribute to the goal of stabilisation of atmospheric CO₂ concentrations. The issue of global warming and the cost of its mitigation is potentially one of the most serious threats to economic development. It is clear that technologies which reduce this cost and accelerate the implementation of CO₂ mitigation schemes will have wide ranging socio-economic benefits. The timescales in which the impacts of climate change will be felt and the CO₂ trajectories with and without CO₂ capture dictate that the benefits of early and widespread deployment must have significant and very long-term global benefits.

INFORMATION

Contract number
019972

Instrument
Integrated Project

Total cost
€ 13.45 million

EC funding
€ 7.58 million

Coordinator
Jonathan Forsyth
BP Exploration - UK
jonathan.forsyth@uk.bp.com

Partners
Air Products - UK
Alstom Power Boilers - FR
Chalmers University of Technology - SE
Chevron Energy Technology Company - US
ConocoPhillips Company - US
Consejo Superior de Investigaciones Científicas - ES
Dalian Institute of Chemical Physics - CN
E.ON UK - UK
Electricity Authority of Cyprus - CY
Endesa Generación - ES
Energy Research Centre of the Netherlands - NL
EniTecnologie - IT
Fraunhofer UMSICHT - DE
Institut Français du Pétrole - FR
Institute for Ecology of Industrial Areas - PL
Meggitt - UK
National Technical University of Athens - EL
Norsk Hydro - NO
Petroleo Brasileiro - BR
Process Design Centre - Shell
International Renewables - NL
Siemens - DE
SINTEF - Stiftelsen for Industriell og Teknisk Forskning ved Norges Tekniske Hogskole - NO
Suncor Energy - CA
Technical University of Sofia - BG
Technip France - FR
Technische Universität Wien - AT

Website
www.cachetco2.eu

Towards Hydrogen Production with CO₂ Management

DYNAMIS

Objectives

DYNAMIS will investigate viable routes to large-scale cost-effective hydrogen production with integrated CO₂ management, for use in power production or other aspects of society. It is designed as an element of the HYPOGEN initiative, part of the European Commission's Quick-Start Programme for the Initiative for Growth. Foreseen to take 10-20 years, HYPOGEN has the goal of providing Europe with a realistic and economically viable route to a hydrogen economy (to be based eventually on renewable energy sources) and includes, as an interim step, the construction of a large-scale test facility for the production of hydrogen and electricity from decarbonised fossil fuels – with permanent CO₂ storage.

DYNAMIS represents the first step on that route, designed to rank the options and reduce the risk element for subsequent development of a full-scale HYPOGEN pilot plant by industry post-2008. Within a time span of three years, DYNAMIS will particularly address five main dimensions that are deemed essential for pursuing the HYPOGEN initiative.

Essentially, the efforts of DYNAMIS include research and extension of common practice in industry and society towards a new energy paradigm. DYNAMIS will involve only intellectual work without any planned demonstration. Its results will mainly be submitted by written reports and by seminars and meetings.

Key Issues

Five topical areas are identified as having a special bearing on the overall objective:

- decarbonisation of fossil fuels facilitating co-production of hydrogen and electric power generation;
- hydrogen separation including cleaning, conditioning and export facilities for piped, tanked or liquefied hydrogen;
- new power cycles requiring a large-scale topping cycle based on gas turbines that operate on hydrogen or hydrogen-enriched fuels (still to be developed for their intended purpose);
- reliable storage of CO₂, via capture, pre-treatment, transport and injection of CO₂ into geological structures or, optionally, for enhanced oil/gas recovery (EOR/EGR);
- societal anchorage, including legal, regulatory, funding and economic aspects, and public issues.

Technical Approach

DYNAMIS will do the assessment and ranking of candidate options (technologies, policy, societal) that are or may become viable in a large-scale co-production scenario of hydrogen and electric power generation from various feedstocks. This includes:

- viability assessment (studies) subjected to the vision of a realistic and economically sound route to feed hydrogen into a (prospective) European hydrogen economy, based eventually on RES;
- transformation of main results into techno-/economic selection criteria pertaining to technology, site locations (plant and CO₂ storage sites), size, stakeholders and players in the supply chain – including the emerging CO₂ branch;
- pre-engineering studies and planning of plants for co-production of hydrogen and electric power including separation of hydrogen and CO₂ (capture);

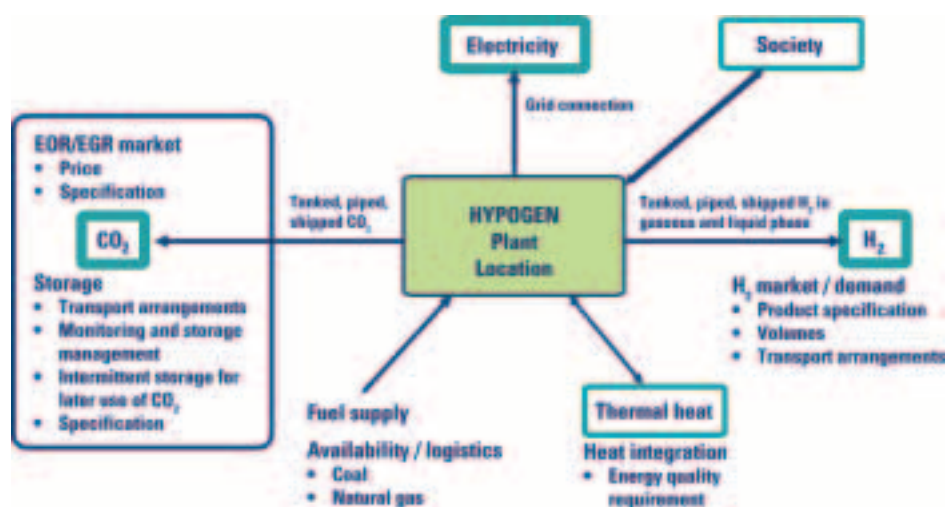

INFORMATION

Contract number
19672

Instrument
Integrated Project

Total cost
€ 7.69 million

EC funding
€ 4.15 million

Coordinator
Nils Rokke
SINTEF Energiforskning AS
nils.a.rokke@sintef.no

Partners
Air Liquide - FR
Alstom Switzerland - CH
Alstom Power Centrales - FR
Alstom Power Environment ECS France - FR
BP - UK
British Geological Survey - UK
Bundesanstalt für Geowissenschaften und Rohstoffe - DE
E.ON UK plc - UK
Ecofys - NL
Electricity Authority of Cyprus - CY
Etudes et Production Schlumberger - FR
Fraunhofer ISI - DE
Geological Survey of Denmark and Greenland - DK
IEA Greenhouse Gas R&D Programme - UK
Institut Français du Pétrole - FR
Joint Research Centre - NL
Netherlands Organisation for Applied Scientific Research - NL
Norwegian University of Science and Technology - NO
Progressive Energy - UK
Public Power Corporation of Greece - EL
Siemens Aktiengesellschaft - DE
SINTEF Petroleumsforskning - NO
SINTEF - NO
Société Générale London Branch - FR
Statoil ASA - NO
Store Norske Spitsbergen Grubekompani - NO
Technical University of Sofia - BG
Vattenfall - SE

Website
www.dynamis-hydrogen.com

- validation of transport and storage options for the CO₂ – including optional use for enhanced oil/gas recovery (EOR/EGR);
- evaluation of opportunities for expanding existing electric power units and/or industrial facilities to comply with the objectives cited;
- identification of financing mechanisms, legal and regulatory frameworks as well as the environmental and public acceptance issues;
- translation of main results into topical policy documents;
- provision of a roadmap for HYPOGEN on technical, economic and societal terms – including how permits can be obtained, how funding can be syndicated, and how a HYPOGEN plant could be generally anchored in society in the context of public acceptance.

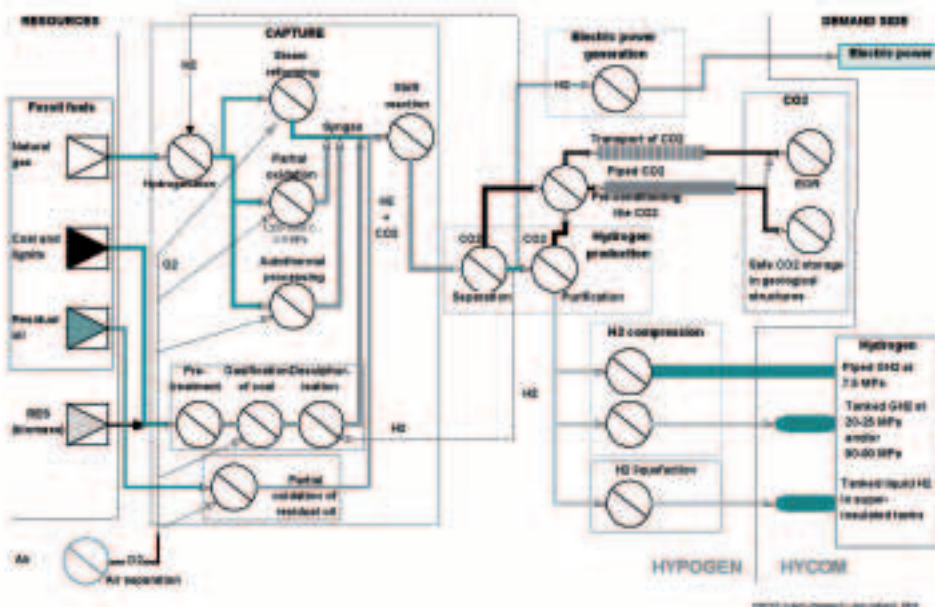

Generalised polygeneration schemes with CCS. The chart was developed by SINTEF Energy Research for the DYNAMIS project aimed to prelude the HYPOGEN demonstration and HYCOM by 2012-2015 under the European Quick-start initiative.



ADVANCED CO₂ SEPARATION PROJECTS

Innovative in situ CO₂ Capture Technology for Solid Fuel Gasification

ISCC

Objectives

The project aims to develop a new process for upgrading high-moisture low-rank brown coals yielding three valuable products:

- a fuel gas consisting mainly of hydrogen;
- a purge gas stream containing > 95% CO₂, ready for transportation to sequestration (CO₂ capture > 90%) or chemical fixation;
- a pre-calcinated feed for a cement kiln consisting of CaO, coal ash and required additional minerals.

Expected results are a detailed definition of an environmentally friendly, highly efficient coal technology producing a highly enriched H₂ product gas via *in situ* CO₂ capture; a detailed technical assessment of process efficiency in terms of energy (coal to H₂) and CO₂ captured (% of input); a life-cycle assessment (LCA) including H₂ production costs and costs per tonne of CO₂ captured; and a European business plan for the exploitation of results.

Key Issues

Screening of available coal and sorbent material and required product quality: available coal and possible sorbent material resources in the EC are analysed and assessed in order to select suitable feedstock materials. The quality of process products, as well as the conditions of CO₂ sequestration, will be defined for an economic operation in a technical plant. Basic process investigations will be carried out in order to develop advanced high-temperature sorbents. Sorption conditions will be studied in order to optimise process efficiency and CO₂ sequestration as well as the economic supply of solid sorbent materials. Pilot-scale experiments will be carried out to validate the results of the basic investigations and demonstrate the technical feasibility of the integrated process. Technical and socio-economic evaluation will assess the results of the investigations and compare the process with other low CO₂-emitting power processes, taking into consideration technical, social, ethical and economic criteria. The evaluation will feature an LCA and a European business plan for the exploitation of results.

Expected Impact

The following will be generated in order to evaluate the technical and socio-economic feasibility of a process based on ISCC technology:

- a detailed technical assessment of process efficiency in terms of energy (coal to H₂) and CO₂ captured (% of input);
- plant design for a semi-technical power facility (1 MW) to investigate the integrated process on a semi-technical level;
- a life-cycle assessment (LCA) including H₂ production costs and costs per tonne of CO₂ captured;
- a European business plan for the exploitation of results.

If the feasibility can be shown, the development will be continued. Once the process becomes commercial, it can be applied in areas where low-grade lignites are available. It has the potential to supply 10-20% of European power production.

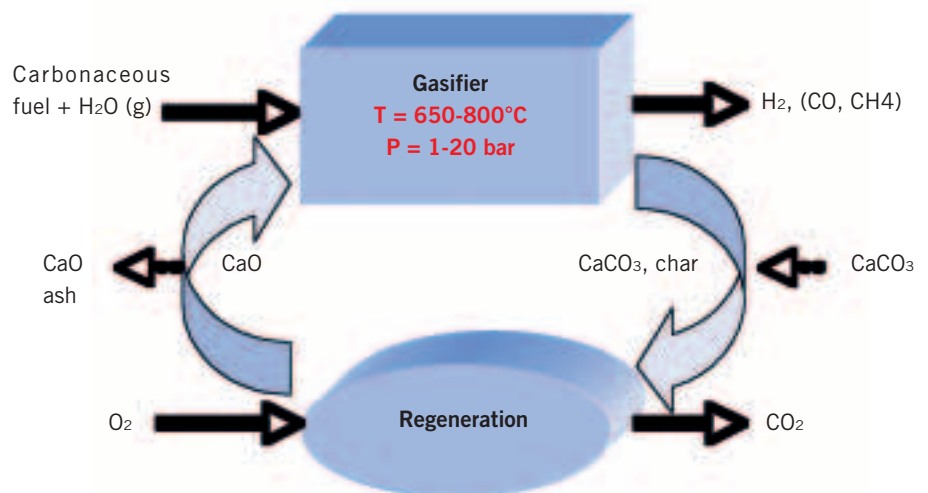

Schematic representation of the ISCC process

INFORMATION

Contract number
502743

Instrument
Specific Technical Research Project

Total cost
€ 2.9 million

EC funding
€ 1.9 million

Coordinator
Dr.-Ing. Roland Berger
Universität Stuttgart - DE
berger@ivd.uni-stuttgart.de

Partners
Centre for Solar Energy and Hydrogen
Research - DE
Consejo Superior de Investigaciones
Científicas - ES
University of Ulster - UK
Central Mining Institute - PL
IVE Weimer - DE
Kopalnia Węgla Brunatnego "Turów"
Akcyjna - PL
National Technical University of Athens - EL
Politechnika Wroclawska - PL
Public Power Corporation of Greece - EL
SCS-Technology - AT
Technical Research Centre of Finland - FI
Brandenburgische Technische Universität
Cottbus - DE
Vattenfall Europe Mining AG - DE

Website
www.eu-projetcs.de

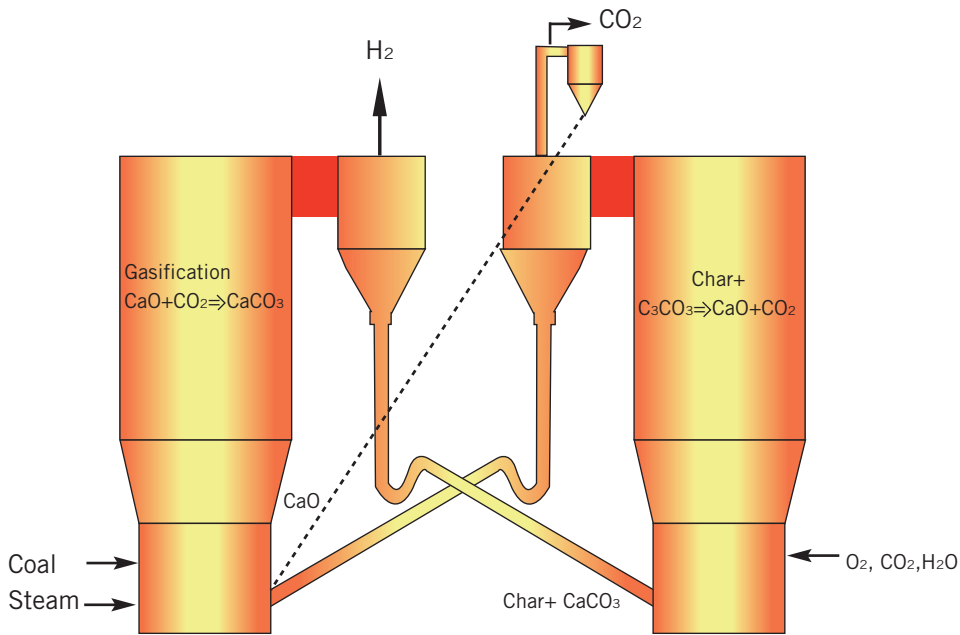

Interconnected fluid bed reactor concept for the ISCC process

Calcium Cycle for Efficient and Low-cost CO₂ Capture using Fluidised Bed Systems

C3-CAPTURE

Objectives

The project aims to develop an advanced dry CO₂ capture system applicable for both PF and CFB boiler systems. Two options for CO₂ capture from boiler systems are investigated: an integrated atmospheric fluidised bed system for post-combustion capture from PF or CFB boilers, and an *in situ* capture system for PFBC boilers. The atmospheric option will be directed to the development of a pilot plant application. For the pressurised option, the project will seek a proof of principle to determine if the expected benefits of a pressurised capture system can balance the known limitations of PFBC systems. The quantifiable objectives of the development are:

- low CO₂ capture costs (< for atmospheric, < 12€/tonne for pressurised systems);
- low efficiency penalty for CO₂ capture (6% ^{el} including CO₂ compression to 100 bar). The efficiency penalty is even lower (4%) when considering the integration with a cement plant where precalcined feed reduces energy consumption and CO₂ release;
- > 90% carbon capture for new power plants and > 60% for retrofitted existing plants;
- a calciner gas stream containing > 95% CO₂ (dry base);
- a solid product usable for cement production;
- simultaneous sulphur and CO₂ removal with sulphur recovery option.

Key Issues

- Process definition: the critical issues of a calcium cycle for CO₂ capture have already been identified in previous work. Based on this knowledge, the process requirements for the sorbents and the three base cases (new atmospheric, retrofitted atmospheric and new pressurised plant) for fluidised bed systems with carbon capture will be defined.
- Selection and improvement of sorbent materials: attrition and capture activity of the sorbents will be addressed by multi-cycle testing in order to assess the expected sorbent lifetime and performance. New sorbent pre-treatment and reactivation technologies will be developed to increase the sorbent lifetime.
- Lab-scale investigation of combined CO₂/sulphur removal: The combined CO₂ and SO₂ capture is an intrinsic advantage of the technology. Investigations will focus on optimum conditions for both SO₂ and CO₂ capture, and competing effects. Furthermore a staged regeneration, yielding separate CO₂ and SO₂ streams, will be tested.
- Experimental testing: atmospheric and pressurised processes will be tested in existing semi-technical scale FB equipment to determine capture performance and sorbent behaviour under realistic conditions. This includes comprehensive calcinations and carbonation testing in different atmospheres and pressures, as well as integrated testing of the closed loop continuous operation.
- Technical and economic evaluation: process efficiency and CO₂ capture costs will be calculated for the three base cases, assuming a 250 MWe power plant to assess the commercial feasibility of the process. This task includes an LCA for the most promising option.

- Pilot plant design: layout and design work for the modification of a 1 MW_{th} CFB pilot plant for a fully integrated pilot plant with integrated C3-capture system. This pilot is the intermediate step for a first demonstration for an atmospheric capture unit, which is expected to be the first commercial process.

Technical Approach

Limestone is a CO₂ carrier. The CO₂ can be released easily in a conventional calcination process which is well known in the cement and lime industry. By integrating a closed carbonation/calcination loop in the flue gas of a conventional CFB boiler, the CO₂ in the flue gas can be removed. The heat required for calcination is released during carbonation and can be utilised efficiently (i.e. at high temperature) in the steam cycle of the boiler. Highly concentrated CO₂ can be generated when using oxygen-blown calcination. Because the fuel required for supplying sufficient heat for calcination is only a fraction of the total fuel requirements, the required oxygen is only about 1/3 to 1/2 of the oxygen required for oxyfuel processes. Since limestone is a low-cost material with good geographical distribution, it allows the use of local limestone resources from power plants for CO₂ capture with minimal limestone-related infrastructure investment.

INFORMATION

Contract number
019914

Instrument
Specific Technical Research Project

Total cost
€ 2.72 million

EC funding
€ 1.8 million

Coordinator
Mrs Anja Schuster
Universität Stuttgart - DE
anja.schuster@ivd.uni-stuttgart.de

Partners
Alstom Power Boilers - UK
CANMET Energy Technology Centre - CA
CEMEX Trademarks Worldwide - CH
Consejo Superior de Investigaciones Científicas - ES
Cranfield University - UK
Empresa Nacional de Electricidad - ES
Główny Instytut Górnictwa - PL
IVE Weimer - DE
The All-Russian Thermal Engineering Institute - RU
The Southern Power Generation Concern - US
Université de Mulhouse - FR

Website
www.eu-projects.de

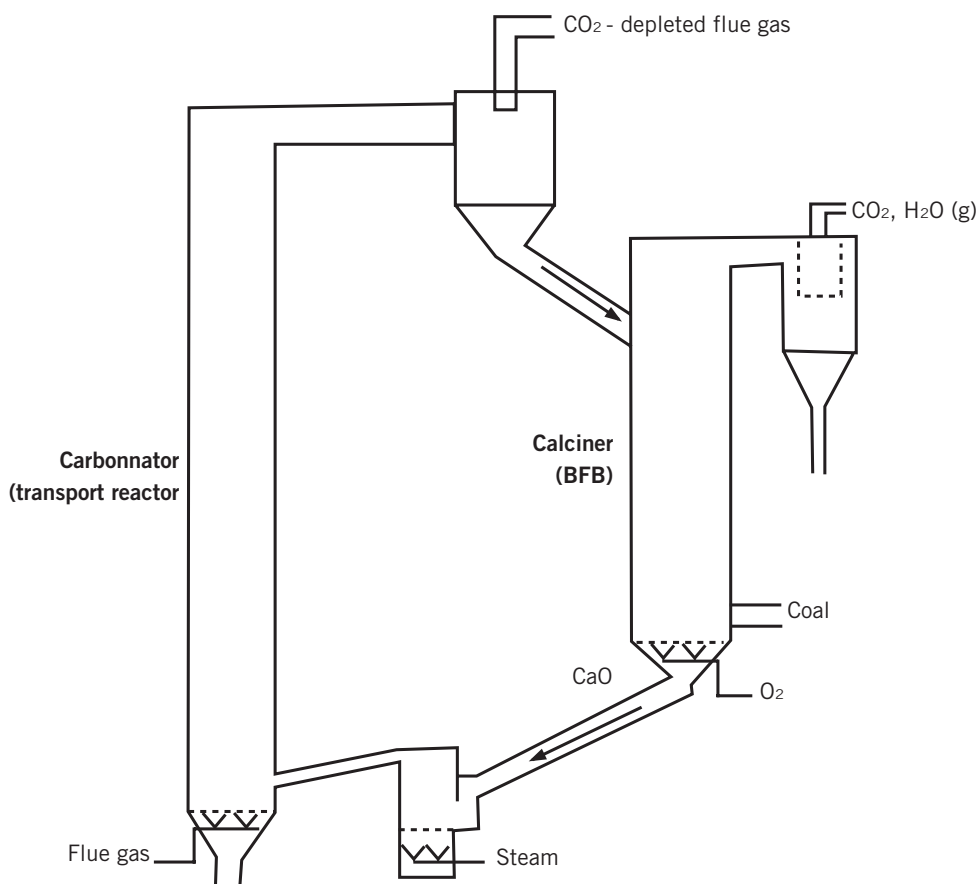

Chemical Looping Combustion CO₂-Ready Gas Power

CLC-GAS POWER

Objectives

Chemical looping combustion (CLC) is a new, indirect combustion process with inherent separation of CO₂. The CLC technology uses metal oxide particles for oxygen transfer from combustion air to fuel, thus CO₂ is obtained in a separate stream without any gas separation needed.

The process features 100% CO₂ capture, a highly concentrated stream of CO₂ ready for sequestration, no NO_x emissions, and no costs or energy penalties for gas separation. CLC uses well-established boiler technology very similar to circulating fluidised bed boilers, which also means that costs can be assessed with great accuracy. CLC is estimated to achieve CO₂ capture cost reductions of 40-50% compared to today's best available technology, namely post combustion amine scrubbing.

Critical issues for an up-scaling of CLC to a demonstration phase of 20-50 MWe have been identified. The project will:

- establish industrial-scale metal oxide particle production including availability of suitable commercial raw materials;
- extend operational experience in long-term tests of particles in available prototype, >1000 hours;
- scale up process to 100/200 kW_{th} with advanced features, using existing CFB rig;
- extend and verify modelling capability for scale-up;
- perform process and technology scale-up to prepare for industrial 20-50 MWe demonstration unit and produce update of economic assessment.

Key Issues

The critical issues that need to be addressed for an upscaling of this CLC technology to a demonstration step have been identified jointly by the industrial and university/research partners. It is the objective of the project to establish and validate solutions to these issues, thereby enabling a future demonstration phase. These issues include:

- identify process suitability of raw materials commercially available at competitive prices;
- establish best commercial particle production technique for upscaling from the laboratory freeze-granulation method so far applied;
- adapt alternate particle production paths with potentially lower production costs;
- investigate possible effects of gas impurities on particles, primarily sulphur;
- long-term testing in an existing 10 kW_{th} CLC prototype unit to confirm mechanical and chemical integrity of particles;
- testing of intermediate CLC demonstration unit at 100-200 kW_{th} scale;
- extend and verify modelling capability for process performance optimisation and scale-up;
- process and technology scale-up to prepare for industrial 20-50 MWe demonstration unit.

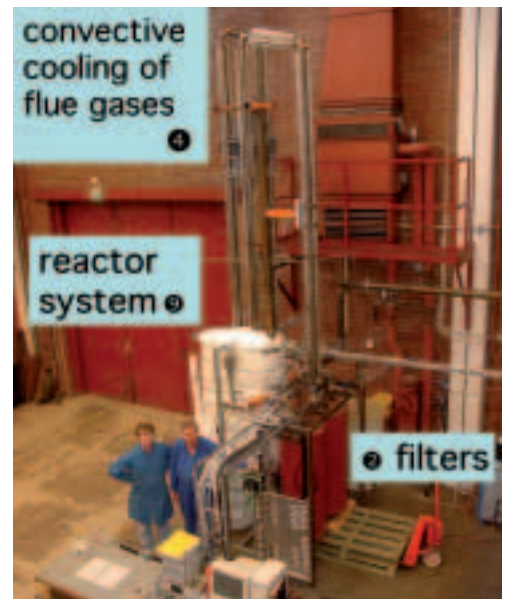

Chalmers' 10 kW chemical-looping combustor

Technical Approach

- Identify process suitability of raw materials commercially available at competitive prices. The particles produced in the previous GRACE project were based on expensive so-called pro-analysis chemicals of the highest possible purity, in order to avoid any uncertainties regarding effects of impurities. For cost reduction reasons, it has to be verified that raw or semi-finished materials commercially available are equally effective.
- Establish best commercial particle production technique for upscaling from the laboratory freeze-granulation method so far applied. The laboratory production method used, freeze-granulation, is suitable for smaller batches but, for large-scale production, spray-drying appears to be the best method. Spray-drying is a common industrial practice for producing large amounts of particles at low cost.
- Adapt alternate particle production paths with potentially lower production costs. The use of commercial techniques for catalyst preparation

INFORMATION

Contract number
019800

Instrument
Specific Technical Research Project

Total cost
€ 2.13 million

EC funding
€ 1.7 million

Coordinator
Prof. Anders Lyngfelt
Chalmers University of Technology - SE
anders.lyngfelt@me.chalmers.se

Partners
Alstom Power Boilers - FR
Consejo Superior de Investigaciones Científicas - ES
Shell Global Solutions International - NL
Tallinn University of Technology - EE
Technische Universität Wien - AT

Website
www.entek.chalmers.se/~anly/co2/CLCGasPower.html

can be adapted to achieve lower costs, since the fraction of nickel oxide needed may be significantly decreased. Furthermore, the sintering can be achieved at lower temperatures resulting in cost reduction.

- Investigate possible effects of gas impurities on particles, primarily sulphur. It is important to safely assess the effect of the presence of impurities in the gas feed (sulphur and higher hydrocarbons) on the process, and to analyse possible implications for the process design. First, it is necessary to assess whether there are process conditions under which particles can be damaged by the presence of sulphur. Secondly, it is important to find out whether any sulphur is transported to the air reactor and released there, and whether to assess the fraction of sulphur released in the air reactor in view of the possible need for flue gas cleaning.
- Long-term testing in an existing 10 kW_{th} CLC prototype unit to confirm mechanical and chemical integrity of particles. Although the GRACE tests clearly suggest that the lifetime of the particles should be very long, this needs to be verified in long-term operation of the process. In view of the operational costs, this

long-term testing needs to be made in the smaller 10 kW existing CLC unit available. This unit is adequate for this, except that it needs to be equipped for unmanned operation. The target lifetime of particles is minimum 4 000 hours. The target is based on a cost of particles below 1 €/ton CO₂ captured, in combination with present assumptions on particle inventory and particle production cost.

- Testing of intermediate CLC demonstration unit at 100-200 kW_{th} scale. The scale-up from 10 to 100-200 kW has been identified as an appropriate step, given that this is a completely new combustion technology. After modification, the unit will include a number of features not available in the smaller 10 kW unit, and will provide vital information on scaling-up, operational control principles to simulate part-load operation and upset conditions, particle behaviour and emissions.
- Extend and verify modelling capability for process performance optimisation and scale-up. Reliable models and process simulation are key scale-up tools for performance mapping and for executing the development of a well-engineered integrated CLC Process layout. Detailed modelling studies, based on GRACE achievements, are required for air and fuel reactor and will be benchmarked by experimental results of the 100/200 kW pilot reactor. A global simulation model will be set up for process optimisation, which is essential for analysis of process integration options, part-load behaviour and off-design operation.
- Process and technology scale-up to prepare for industrial 20-50 MWe demonstration unit. Environmental assessment is needed to ensure the process meets high standards of environmental performance and workplace safety. In order to fully understand the commercial viability of the process for a large-scale unit, it is vital to use information from WPs 1-7 to develop an integrated design.

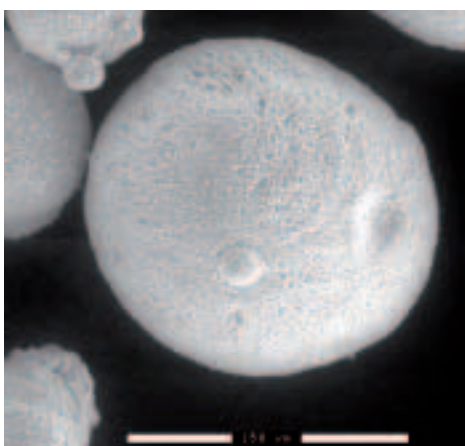

Oxygen-carrier particle using nickel oxide for oxygen transfer

Advanced separation and storage of carbon dioxide: Design, Synthesis and Applications of Novel Nanoporous Sorbents

DESANNS

Objectives

CO₂ capture process represents the most significant cost involved in CO₂ capture transport sequestration and is estimated at about 75% of the total cost. The currently used amine-based systems for CO₂ removal have several disadvantages such as additional processing with a dehydration unit, considerable heat regeneration of the solvent and corrosion control. Such problems can be overcome by using a PSA-based system. In natural gas upgrade, the replacement of the usual amine- CO₂removal process by a PSA one is expected to lead to a 20% reduction of operation costs resulting in a saving of around € 1.2 million per year per process.

However, the adsorbents that most readily adsorb CO₂ – such as the zeolites that are used for removal of trace amounts of CO₂ – are difficult to regenerate without heating. Thus conventional processes suffer from low productivity and high operating costs. Another problem arises in that in thermal processes such as biomass energy conversion, the CO₂ which requires capturing is produced at high temperature, whereas the separation process needed for CO₂ purification that may follow is more likely to occur at room temperature. One may therefore require a specific nanoporous material for each process. The use of such nanomaterials should successfully replace traditional, pollution-prone and energy-consuming separation processes. Furthermore, synthesis gas (syngas) is produced from methane (natural gas) as an intermediate step in the production of hydrogen.

Key Issues

Five aspects are tackled during the project:

- What are the most appropriate building block for an adsorbent?
- What are the best pore sizes and architectures?
- How do adsorption properties agree with those predicted from calculations obtained for materials designed from the two first points?
- What are the industrial prospects in terms of the scale-up of the synthesis of the novel adsorbents pinpointed above?
- How does the adsorbent behave with respect to specific applications involving environmentally sensitive gases?

The basic building blocks required for adsorbent synthesis will be investigated with respect to gas interactions. Such groups will include metals, cations, silicon/aluminium wall ratio and organic ligands. After choosing a zeolite benchmark, the project will concentrate on the synthesis of two families of nanoporous materials: periodic mesoporous oxides and metal organic frameworks. An experimental/modelling approach will be followed to search the most suitable materials with the most appropriate building blocks, pore size and architecture. The materials will be characterised by adsorption of carbon dioxide and tested under industrial conditions. Several materials will be studied for synthesis up-scale. A test application of CO₂ elimination during H₂ production from syngas will be investigated before providing a generic modelling tool to select adsorbents for further applications.

Technical Approach

Parameters from these studies can be input into models and computer simulations to extend the initial screening to other chemical compositions and compensating cations. These benchmark studies can then be used as a basis for the investigation of novel materials. Amongst the potential materials that could be used for applications with respect to carbon dioxide, we will concentrate on two options.

The first option is to use Periodic Mesoporous Oxides (PMO) such as the MCM and SBA series. These aluminosilicate materials possess long-range order and well-defined regular pore structures in the mesopore (20-100Å) range, but are amorphous at the atomic length scale. Whilst the basic materials have large pore volume, the adsorption properties are certainly not optimal with respect to carbon dioxide. There is a possibility however, to graft ligands or to occlude metal sites on the surface of such materials which can be specific to the adsorption of carbon dioxide. Such hybrid materials, with amine ligands for example, allow us to produce a tailored surface layer in which the CO₂, in effect, “dissolves” in a similar way to e.g. amine-based adsorption processes. The opportunity to test other ligands, e.g. exploiting the quadrupolar nature of CO₂, should also be pursued. Furthermore, we can transfer parameters from the initial zeolite benchmark such as the optimal Si/Al ratio by modifying the chemical composition of the PMO. Such materials can provide an encouraging pathway to explore, as preliminary results of Partner 4 indicate that involving this type of adsorbent in a PSA process is

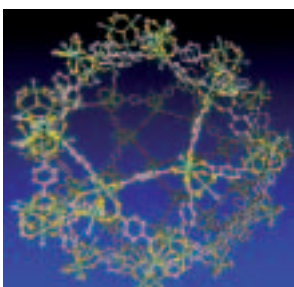

promising; as the adsorbent is less strongly adsorbing than a typical zeolite but the usable capacity in a PSA cycle is actually higher.

The second direction to explore with respect to new materials is to use metal-organic frameworks. Metal-organic framework (MOF) nanoporous materials can be synthesised with many of the functional capabilities of zeolites. As they have similar framework structures, metal-organic framework materials are sometimes referred to as “metal-organic zeolites” although they are not true zeolites. These materials are synthesised in a self-assembly process from different building blocks and generally consist of metal vertices interconnected by organic linker molecules as shown schematically below. Such systems have been shown to be stable under vacuum up to 500°C which make them ideal for PSA-type applications. In addition they are characterised by a low density, and the chemical syntheses are relatively inexpensive and environmental-friendly as they are non-toxic.

INFORMATION

Contract number
020133

Instrument
Specific Technical Research Project

Total cost
€ 3.51 million

EC funding
€ 2.5 million

Coordinator
Philip LLEWELLYN
Centre national de la recherche
scientifique - FR
pllew@up.univ-mrs.fr

Partners
Institut Français du Pétrole - FR
J. Heyrovský Inst. of Physical Chemistry - CZ
P.J. Safarik Kosice University - SK
Royal Institution - UK
Universitat Rovira i Virgili - ES
University of Manchester - UK
University of Edinburgh - UK
University of Saint Andrews - UK

Website
www.desanns.univ-montp2.fr

Objectives

The main goal of this project is the development of a hybrid membrane/Pressure Swing Adsorption (PSA) H₂/CO₂ separation process, which will be a part of a fossil fuel de-carbonisation process used for pre-combustion CO₂ capture. Methane steam reforming is currently the major route for hydrogen production and will be employed as a model case. High purity hydrogen (99.99+%) is usually recovered from the reformat by using a PSA process. A typical PSA waste gas stream (CO₂-55%, H₂-35%, CH₄ & CO-15%) is not usually recycled since it has to be recompressed to the PSA feed pressure in order to recover only a small fraction of the recycled hydrogen. Furthermore, it cannot be used for CO₂ sequestration since it contains significant amounts of H₂ and CH₄.

Hybrid Hydrogen – Carbon Dioxide Separation Systems

Key Issues

A hybrid process is expected to combine the high throughput and H₂ product purity of a PSA process with the lower operating costs of a membrane process. It is expected to enhance the overall H₂ recovery and provide an H₂-free CO₂ stream ready for capture and sequestration. The key issues that have to be addressed before implementing such an approach are the following:

- material research related to existing and new membrane and sorbent materials;
- generation of transport and adsorption data for H₂/CO₂ multicomponent mixtures (CH₄, H₂O, CO) for well characterised membrane and sorbent materials;
- development and improvement of membrane and PSA separation models;
- design and optimisation of membrane, PSA and hybrid separation systems using the improved models developed;
- component design for the manufacture of a lab-scale hybrid separation system prototype;
- assessment of the hybrid separation process sustainability and impact on the environment based on a life cycle analysis approach.

The following possible innovations are foreseen as an outcome of this project:

- H₂ recovery improvement;
- simplification of PSA operation (reduction of steps) without loss of recovery and product purity;
- co-production of high purity H₂ and CO₂ streams;
- development of improved membrane and sorbent materials.

Technical Approach

The main goal of the proposed work is the design of a hybrid membrane/Pressure Swing Adsorption (PSA) H₂/CO₂ separation process. The general objectives comply with SP1-Priority 6-1 Work Programme and more specifically with the research area topic “Advanced separation techniques” of the thematic priority 6.1.3.2.4 entitled “Capture and sequestration of CO₂ associated with cleaner fossil fuel plants”. A hybrid process is expected to combine the very high throughput and purity of a PSA process with a membrane separation process that will increase the overall H₂ recovery and provide a CO₂ stream ready for capture and sequestration. In order to achieve this goal during the course of this R&D project the following scientific and technological objectives have been identified:

- generation of transport and adsorption data for H₂/CO₂ mixtures for well characterised membrane (zeolite, carbon molecular sieve and transition metal oxides) and sorbent (hydrotalcites, zeolites, carbon molecular sieves) materials (Milestones 2.2, 2.4, 2.5, 3.2, 3.4, 3.5);
- assessment of the effect of minor species (CH₄, H₂O, CO) in the membrane and sorbent material performance (Milestones 2.2, 2.4, 2.5, 3.2, 3.3, 3.5);
- detailed membrane and sorbent characterisation;
- development and improvement of membrane and PSA separation models (Milestones: 2.3, 3.3, 4.1, 4.3, 5.1, 5.3);
- design and optimisation of membrane and PSA separation units using the improved models developed (Milestones: 4.4, 5.4);
- process design of hybrid membrane-PSA separation systems (Milestone: 6.2);

INFORMATION

Contract number
019887

Instrument
Specific Technical Research Project

Total cost
€ 2.53 million

EC funding
€ 1.56 million

Coordinator
Dr. Vladimiro Nikolakis
Foundation for Research and Technology
Hellas - EL
vnikolak@iceht.forth.gr

Partners
Ceramiques Techniques et Industrielles - FR
Hygear - NL
Imperial of Science Technology
and Medicine - UK
Polish Academy of Sciences - PL
Process Systems Enterprise - UK
Universidade do Porto - PT

Website
<http://hy2seps.iceht.forth.gr>

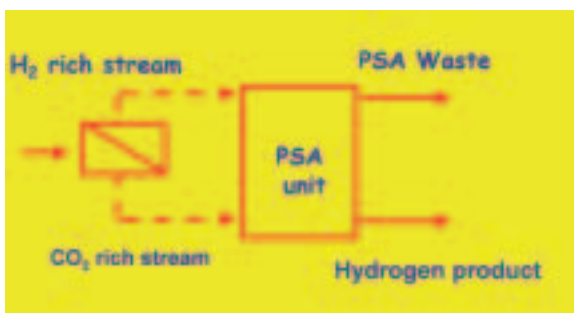
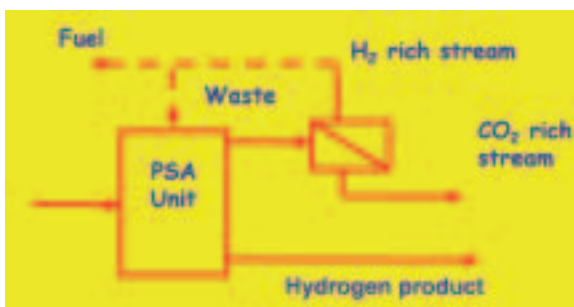
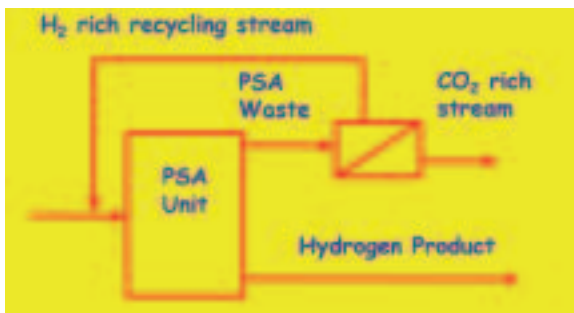

- component design for the manufacture of a lab-scale hybrid separation system prototype (Milestone: 4.2, 5.2, 6.1);
 - overall assessment of the hybrid separation process sustainability and impact on the environment based on a life cycle analysis approach (Milestones: 7.1, 7.2).
 - co-production of high-purity H₂ and CO₂ streams (H₂ purity at least 99.99+%, CO₂ purity 99%+);
 - development of improved membrane materials (CO₂ selective membranes: flux: 50 mmol.m⁻².s⁻¹, separation factor: 10. H₂ selective membranes: flux: 50 mmol.m⁻².s⁻¹, separation factor: 50);
 - development of improved sorbent materials (capacity: 2.5-5 mol/Kg at 30°C, adsorption rate: 2.10⁻² sec⁻¹ at 1.14 bar).
- Upon completion of the above objectives, the following possible innovations are foreseen as an outcome of this project:
- H₂ recovery improvement (5% improvement of H₂ recovery);
 - simplification of PSA operation (reduction to 5 steps instead of 7) without loss of recovery and product purity;



CO₂ STORAGE PROJECTS



CO₂SINK

Objectives

The aim of the CO₂SINK project is *in situ* testing of the geological storage of CO₂. It will advance the understanding of the science and of the practical processes involved in underground storage of CO₂ in a saline aquifer as a means of reducing emissions of greenhouse gases to the atmosphere. The storage site near the town of Ketzin, close to Berlin, includes industrial land and infrastructure which make it suitable as a testing ground for underground injection of CO₂ in a deep saline aquifer. Being close to a metropolitan area, the test site provides a unique opportunity to develop a European showcase for onshore CO₂ storage. It is designed to accelerate public acceptance of the geological storage of CO₂ as a greenhouse gas mitigation option for the benefit of the European Community. The development of capture and storage systems requires targeted research on pilot projects specifically set up to observe the fate of carbon dioxide injected underground with regard to the quality of the seals, including the chance of leakage through overlying strata, upward migration of gas along artificial pathways, migration of the CO₂ within the reservoir, and the rate at which CO₂ dissolves in brine-filled reservoirs or reacts with indigenous minerals. The CO₂SINK project aims to develop such an *in situ* laboratory for CO₂ storage to fill the gap between numerous conceptual engineering and scientific studies on geological storage and a fully fledged onshore storage demonstration unit.

In situ R&D Laboratory for Geological Storage of CO₂

Technical Approach

The development of the CO₂ storage facility at Ketzin makes use of existing infrastructure at the gas storage facility in addition to three new wells which are planned to be drilled to inject CO₂ and monitor changes in the reservoir. Setting up the storage facility, surveying the site, characterising the sub-surface rocks and fluid, overseeing drilling, and managing the flow of information within the project are all part of the work plan. The work programme of CO₂SINK started with preparation of a baseline survey of the site and the target reservoir and the carrying out of a detailed risk assessment to ensure that the experiment can be conducted safely. The necessary approvals and consent of local authorities and residents have been sought.

The plan is to inject some 10 to 30 kilotonnes per year of pure CO₂ into the reservoir over two years. The source of the CO₂, which will come by tanker truck, is the hydrogen production flue gas from the Leuna oil refinery, which is some 150 km from Ketzin. Detailed laboratory tests are being made of samples of rocks, fluids and micro-organisms from underground. *In situ* measurements and experiments will be conducted in boreholes. Surface seismic imaging and borehole seismics are used, together with novel permanent monitoring instruments at the surface and downhole. The test site will be used for upscaling the laboratory results to the field scale, for the development of monitoring methods, and as a basis for modelling scenarios. All these steps will help to prepare for the injection of CO₂ underground, to follow its fate over long periods of time, and to evaluate the reservoir's stability and integrity.



Key Issues

Direct sampling and *in situ* observation of key parameters, as well as critical testing of geological models based on surface observations, are indispensable for the safe and sustainable use of the subsurface. An integrated drilling technology, including time- and cost-saving drilling procedures, selection of completion layout and materials tailored to provide long-term sealing of wells, *in situ* down-hole measurement, and monitoring of physical and chemical parameters combined with surface investigations, comprises the appropriate combination of tools. Tasks include the development of special logging strategies, the development of specific sample handling and field laboratory techniques, and the installation of project-designed Internet-based data and information systems to enable immediate access to the data for all project participants. Thus, the main topics to be addressed by CO₂SINK are storage site development, including securing the necessary permits, baseline surface geochemistry of CO₂ and geomicrobiology, geological and geophysical site pre-survey, laboratory studies on rock-/fluid interactions, numerical modelling of dynamic flow behaviour, risk assessment, drilling, logging and casing, design and installation of permanent downhole sensors, *in situ* monitoring of the CO₂ migration in the reservoir rock, development of a drilling and storage information system, and public outreach.

INFORMATION

Contract number
502599

Instrument
Integrated Project

Total cost
€ 30 million

EC funding
€ 8.7 million

Coordinator
Prof. Dr. Günter Borm
GeoForschungsZentrum Potsdam - DE
gborm@gfz-postdam.de

Partners
Det Norske Veritas - NO
E.ON Energie - DE
GEOS Freiberg Ingenieurgesellschaft - DE
Geological Survey of Denmark and Greenland - DK
IEA Greenhouse Gas R&D Programme - UK
Mineral and Energy Economy
Research Institute - PL
RWE Power - DE
Schlumberger Carbon Services - UK
Shell International Exploration
and Production - NL
Siemens Power Generation - DE
Statoil - NO
University of Kent - UK
Universität Stuttgart - DE
Uppsala University - SE
Vattenfall Europe Mining - DE
Verbundnetz Gas - DE
Vibrometric Oy Cosma - FI

Website
www.co2sink.org

Expected Impact

The location of CO₂SINK at Ketzin has a number of appealing features: the existing surface infrastructure from the gas storage site greatly reduces the need for new developments; the geology of the site is known and is representative of large parts of Europe, which facilitates the transfer of results; and the local political community strongly supports the project. The strategic impact of the proposed CO₂SINK project will be to show policy-makers and the general public that geological storage can be undertaken effectively and with no adverse affect on the local population and the natural environment.

Being a real-life project, CO₂SINK will go a long way to advance the deployment of geological storage as an option enabling significant cuts in CO₂ emission in the future. In particular, the project will shed light on the cost-competitiveness of storage compared to other methods of reducing emissions, and whether or not the benefits of implementing the technology outweigh

its disadvantages. The envisaged test facility will attract considerable international interest and will most likely contribute to setting the standards for future large-scale CO₂ storage activities. Successful execution of the CO₂SINK project will provide techno-economic confidence for subsequent full-scale demonstration projects to be undertaken by power companies and hydrogen manufacturers.

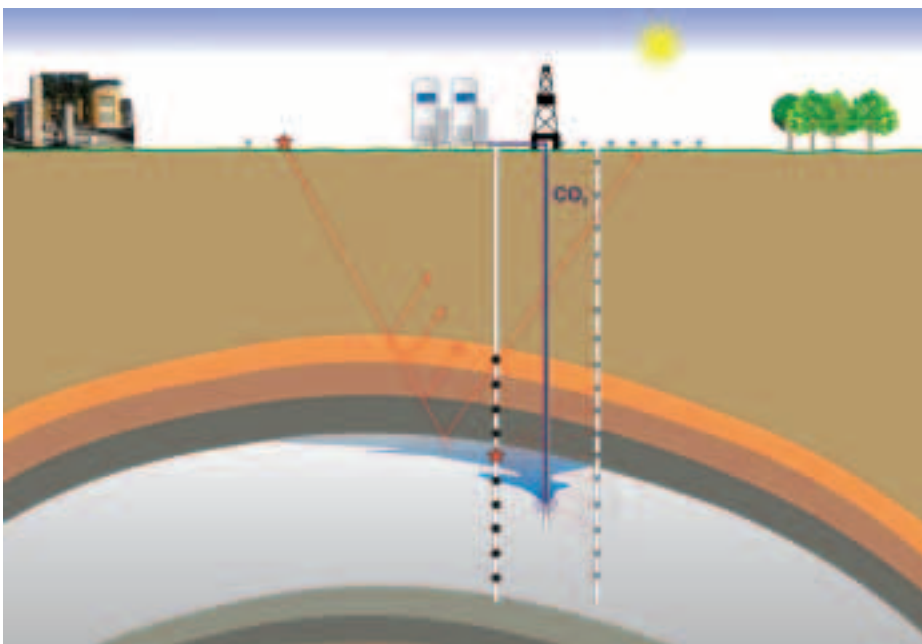
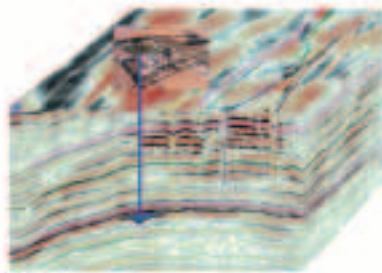



CO₂GEONET

Objectives

The initial partnership will be between 13 institutes, most of which have a long and established history of research in geological storage. Some new players are also included, either because they are expected to have significant national strategic profile in future CO₂ storage projects, or they have capabilities which can be realigned to strengthen the network, or even bring uniqueness. For the first time in an EC FP project, marine biologists will be drawn into this research topic. This should lead to:

- improved efficiency through the realignment of national research programmes, prevention of duplication of research effort, and sharing of existing and newly acquired infrastructure and IPR;
- identification of knowledge gaps and formulation of new research projects and tools to fill these gaps;
- external funding from national and industrial programmes in order to diversify, build and strengthen the portfolio of shared research activities;
- formation of the authoritative body for technical, impartial, high-quality information on the geological storage of CO₂, to enable public confidence in the technology, participation in policy, and regulatory and common standards formulation;
- provision of training to strengthen the partners, addition of new network members, and a sustainable replacement supply of researchers for the future;
- exploitation of network IPR.

Network of Excellence on Geological Sequestration of CO₂

Key Issues

World projections of energy use show that fossil fuel dependency will continue to 2030 and beyond, but sustainability will need a 60% reduction in CO₂ emissions by 2050. This will be difficult and will require various strategies. The associated rise in global CO₂ emissions, without abatement, will be at an average rate of 1.8% per annum (from the current value of 25Gt p.a. to 38Gt by 2030) – a rise of over 50%. This will be catastrophic for the planet's sustainability. Urgent action is needed.

Europe's CO₂ emissions will rise by an average of 0.6% p.a. up to 2020, from a 2000 level of 3.1Gt to 3.5Gt by 2020. The rocks under the North Sea have a theoretical capacity for storing over 800Gt of CO₂. Capturing CO₂ from industrial point sources and storing it underground (a process that mimics nature) is a very attractive route to making cuts in CO₂ emissions. CO₂ capture and storage allows diverse fuel inputs/outputs, enhances security of supply, and is well aligned with hydrogen production from fossil fuels. Through the Joule 2, FP4 and 5 projects, Europe has led the world in R&D in this area, with rapid growth this decade. National programmes are also emerging.

But this success has a downside, creating fragmentation through diversification. North America, despite its rejection of Kyoto (except Canada), has recently embraced CO₂ capture and geological storage and is allocating huge resources (over \$4bn) over the next ten years. As a result, Europe risks losing its head start. Therefore, we must work more effectively and restructure accordingly. The main aim of CO₂GeoNet will be to integrate, strengthen, and build upon the momentum of previous and existing European R&D, as well as to promote European excellence internationally so as to ensure that Europe remains at the forefront of CO₂ underground storage research.

Technical Approach

The project is divided into three main areas – integrating activities, jointly executed research, and the spreading of excellence. In the initial 18 months, work will concentrate on inventories of relevant infrastructure, staff capabilities and the results of CO₂ storage research to date. This will enable identification both of gaps in the research and infrastructure and areas of overlap. Areas of new collaborative research in a wide range of disciplines will be proposed to fill these gaps, and some of these will be carried out in the remaining 42 months. Decisions will also be made as to how best to make such research most efficient. A programme of staff training and deployment will be developed and concerted efforts will be made to disseminate information about CO₂ sequestration both to the general public and to decision- and policy-makers.

Expected Impacts

Contribution to standards: the project will impact upon the development and provision of 'best available technology' through its R&D programme in the Joint Programme of Activities and the dissemination of the outputs to commerce, policy-makers and society. These will cover CO₂ storage site selection, injection operations, monitoring, verification, safety and environmental protection. The Network of Excellence will also contribute to training standards. These contributions will not only impact on standards in Europe but on those internationally. If underground storage becomes a recognised technology for carbon storage in terms of carbon trading, then the input of the NoE into monitoring and verification of storage will be vital.

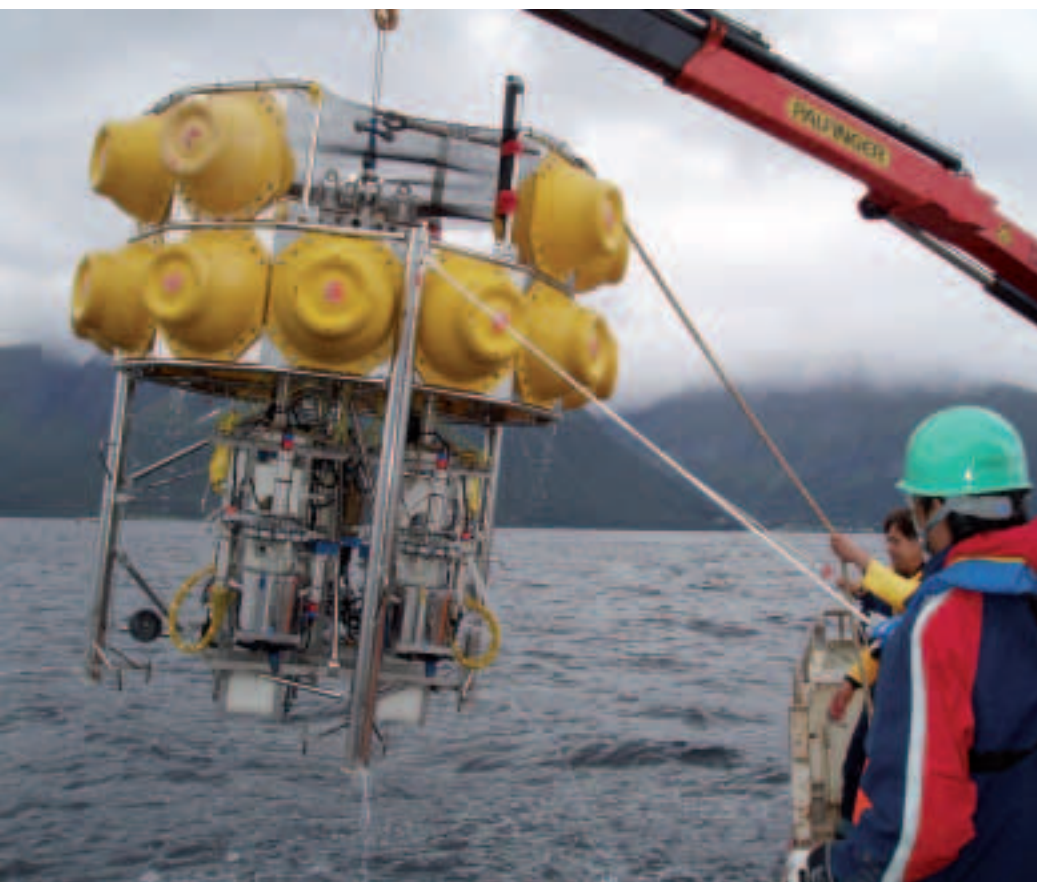

INFORMATION

Contract number
502816

Instrument
Network of excellence

Grant for integration
€ 6 million

Coordinator
Dr Nick Riley
British Geological Service - UK
njr@bgs.ac.uk

Partners
Bundesanstalt GeoWissenschaften und Rohstoffe - DE
Bureau de Recherches Géologiques et Minières - FR
Geological Survey of Denmark and Greenland - DK
Herriot-Watt University - UK
Imperial College of Science and Technology - UK
Institut Français du Pétrole - FR
Istituto Nazionale di Oceanografia e di Geofisica Sperimentale - IT
Netherlands Organisation of Applied Scientific Research - NL
Norwegian Institute for Water Research - NO
SINTEF Petroleumsforskning - NO
International Research Institute Stavanger - NO
Università di Roma 'La Sapienza' - IT

Website
www.co2geonet.com

Contribution to policy developments

Policy-makers and society need confidence in the technology before they will accept CO₂ capture and storage. Regulatory frameworks will need to embrace the technology if it is to succeed. CO₂GeoNet will be actively involved in the review of CO₂ capture and storage commissioned by the Intergovernmental Panel on Climate Change, and will engage with policy-makers and regulators in national governments and the EC. CO₂ capture and storage could also address policy concerns on security of supply and diversity of fuel to meet Europe's primary energy demand. If CO₂ injection is used in enhancing hydrocarbon production, then maximum recovery of Europe's indigenous oil and gas will be possible and hydrocarbon field life will be extended.

Risk assessment and related communication strategy

Even if policy-makers and regulators accept and recognise CO₂ capture and storage as a valid CO₂ mitigation technology, this does not guarantee that society will accept it. CO₂GeoNet therefore needs to engage with society and raise the profile of CO₂ capture and storage technology, and the issues that surround it. The network's R&D outputs will be communicated through technical publications, contribution to policy documents, broadcasting, popular science publications, newspapers, websites, brochures and stimulation of public debate through participation in stakeholder meetings. Many CO₂GeoNet members have already begun this process. CO₂GeoNet will collaborate closely with the FP5 Network 'CO₂Net2' to bring this about. It will also engage with other bodies – for example, the International Energy Agency, and the United Nations Economic Commission for Europe-UNECE which encourages annual stakeholder debate on energy issues through its Sustainable Energy Working Group – well attended by industry, NGOs and candidate countries.

Monitoring and verification of CO₂ storage and ECBM in Poland

MOVECBM

Objectives

The two principal objectives of this project are:

- to address the remaining issues concerning long-term storage of CO₂ in coal not covered by the EC RECOPOL project. These remaining issues are: the monitoring of the long-term sorption behaviour and the associated diffusion of CO₂, well integrity and caprock integrity, as well as the extended surface and mine monitoring and the related guidelines and certification of CO₂ storage in coal;
- the establishment and strengthening of the cooperation in the area of CO₂-ECBM with third countries, such as China, Australia and the USA. It is paramount that the findings of this MOVECBM research project are to a broad extent applicable in these countries with large coal reserves.

Technical Approach

Within the EC RECOPOL project timeframe it was not possible to establish conclusive knowledge of the processes related to CO₂ adsorption and CH₄ desorption in the field, and whether they are operating under similar conditions as can be assumed from laboratory experiments and theory. This is of great importance with regard to specific long-term, reliable and safe storage in coal. In the event that no adsorption takes place, storage is similar to the situation when CO₂ is stored in a normal reservoir. The previous EC RECOPOL project focused on the feasibility of injection and production. This MOVECBM project focuses on the long-term aspects of CO₂ storage in coal and hence the consequences for site certification and standards.

Additionally, the international cooperation has, compared to the previous EC RECOPOL project, broadened: this enables us to make the results of the project applicable to a broader situation, including outside the European Union. Preferably, after the MOVECBM project, this will result in an upscaled (regarding quantities of injected CO₂ and produced CBM) field test in Europe or China.

Next to the scientific and technological programme, this proposal will bring together a worldwide consortium of state-of-the-art universities and institutes in the area of coalbed-related research. The following countries are involved in the project: Germany, France, Slovenia, The Netherlands, Belgium, Poland, Italy, the UK, the USA, Australia and China. Special attention is given to connection with key institutions in the People's Republic of China: RIPED, CUCBM and SKLCC.

Expected Impact

The project has a clear focus on the management and control of health, safety and environmental (HSE) risks of CO₂ storage in coal. For surface facilities, HSE norms are already well developed, as CO₂ is an industrial gas, produced, transported, stored and used for several purposes. For the subsurface, no HSE regulations are available for the pre-operations site assessment, for the construction of the injection plant, or for the monitoring of the safe storage, including the level of sensitivity of the methods to be applied to measure possible well or surface leakage.

This project will integrate technical data and information from across Europe, leading on to relevant legislation at both the European and national level. Onshore, regulatory regimes are less specific. The general principles are outlined below:

- environmental legislation: strategic environmental assessments, and water, habitat and waste directives for storage, will require that special emphasis is put on the difficult task of defining geochemical tolerances for a naturally occurring gas such as CO₂. Methods will be required to cope with a baseline, taking into account heterogeneity in space and time. Added complexity is the fact that the baseline values may be susceptible to changes on the short and long (10 000 years and more) timescale;
- emission trading regulations (mainly European): this refers to good monitoring and verification practice, yet to be defined in detail;



- mining and oil and gas regulation (mainly national): especially the concession rules for CO₂ storage and potential interference with other subsurface functions need to be clarified.

In short, the project is aiming at accelerating the creation of uniform legislation regarding standards for site certification and long-term monitoring at national, European and international level by joining forces and focusing on a consensus on monitoring and verification methods and tools.

INFORMATION

Contract number
038967

Instrument
Specific Technical Research Project

Total cost
€ 2.67 million

EC funding
€ 1.25 million

Coordinator
Pascal Winthagen
Netherlands Organisation for Applied
Scientific Research - NL
pascal.winthagen@tno.nl

Partners
Académie universitaire Wallonie-Bruxelles,
Faculté de Mons - BE
Advance Resources International - US
Central Mining Institute Poland - PL
China United Coalbed Methane Company - CN
Commonwealth Scientific and Industrial
Research Organisation - AU
Environmental Research and Industrial
Co-operation Institute - SI
Etudes et Productions Schlumberger - FR
International Energy Agency - NL
Istituto Nazionale di Oceanografia
e di Geofisica Sperimentale - IT
OXAND France - FR
PetroChina - CN
Rheinische-Westfälische Technische
Hochschule - DE
Shell International Exploration
and Production - NL
State Key Laboratory of Coal Conversion - CN
Università di Roma 'La Sapienza' - IT
Universiteit Utrecht - NL

Website
www.movecbm.eu



CO₂ Geological Storage: Research into Monitoring and Verification Technology

CO₂REMOVE

Objectives

The objectives of the project are to prove the long-term reliability of geological storage of CO₂, and to undertake the research and development necessary to establish scientifically based standards for monitoring future CCS operations. This could in turn lead to guidelines for the certification of sites suitable for CCS on a wide scale.

The research proposed by CO₂ReMoVe partners aims to focus on monitoring and verification technology for CO₂ geological storage by building upon the worldwide lead Europe already has in CO₂ storage operations. The European Network of Excellence (CO₂GeoNet) will progressively align its national funded research activities to underpin CO₂ReMoVe. The network will also facilitate collaboration with non-EU R&D activities on storage in Australia, Canada, Japan, the USA, Russia, India, China and large international industrial initiatives like the CO₂ Capture Project-CCP. The CO₂ReMoVe consortium not only includes most of the CO₂GeoNet members, but also other R&D institutes, oil and gas operators, service suppliers, an SME, a power company and an intergovernmental organisation. It also has strong links with the Carbon Storage Leadership Forum-CSLF, third country academia, and industry and governments in North America through the IEA Weyburn Monitoring Project.

Technical Approach

Crucial to the project portfolio is the continuing large-scale CO₂ injection operation at Sleipner, the newly started injection operation at In Salah (Algeria) and the proposed injection projects of Snohvit (Norway) and Ketzin (Germany). These four sites, together with the Weyburn operation in Canada, will be the largest demonstrations of CO₂ injection/storage in the world. A number of other sites are also in the project portfolio (e.g. K12b, Kaniov, Tarnow). They may provide an adjunct to the large-scale industrial sites, because they are ideal for monitoring CO₂ behaviour in, and close to, the borehole environment (considered to be the highest risk pathway for leakage) and for testing downhole and surface tools without interrupting industrial operations. These sites, together with Weyburn, have been placed on the project 'reserve list'. After the initial 18 months, should opportunities arise, these sites will be considered for research funding from CO₂ReMoVe.

The proposed scientific and technical RTD activities in CO₂ReMoVe are summarised below:

- to develop, consolidate and disseminate all site-specific CO₂ storage experiences with monitoring and verification technology;
- to develop a set of generic public domain and validated **performance assessment and monitoring tools** capable of predicting and measuring the key operational and long-term

processes in CO₂ geological storage sites, and enabling the design of suitable remediation strategies if required. Development will include processes in each relevant compartment of the geosphere, such as reservoir, seal, aquifers and aquitards, as well as the soil, hydrosphere and atmosphere. It will also include innovations to assess impacts, in particular with respect to the coupling of various processes, such as fluid flow, multi-phase interaction, geochemical, mechanical, thermal, chemical and also biological processes. The result will be a (public domain) numerical laboratory, which is based on the best (finite element, finite difference, analytical) simulation and prediction software and stochastic uncertainty analysis software available from the European Network of Excellence CO₂GeoNet. This library will be made available to regulatory bodies, industry and auditing services providers for the licensing and certification of future CO₂ storage sites;

- to provide scientific and technological information to develop recommendations which can be used by regulators, legislators and policy-makers to formulate a consistent and internationally accepted standard for Health, Safety and Environmental (HSE) risk management and certification under the Clean Development Mechanism (CDM), Joint Implementation (JI), Emissions Trading



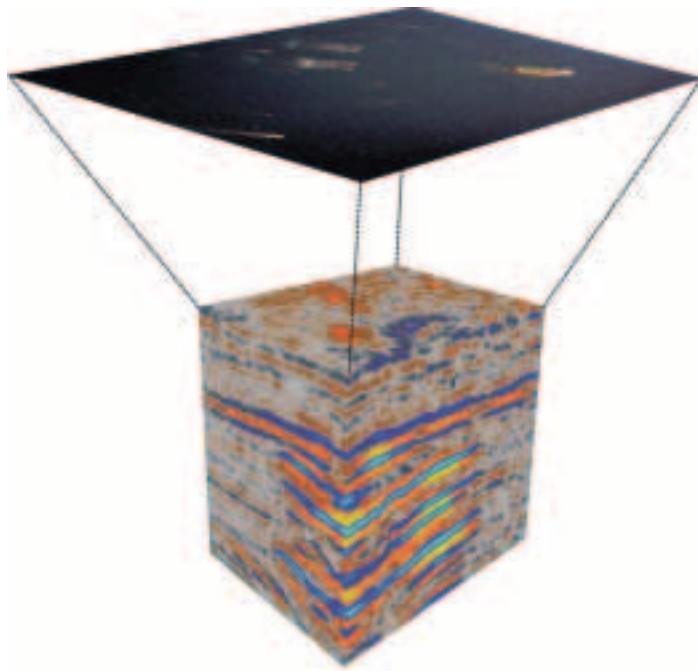

Scheme (ETS) and future national and inter-governmental mechanisms for greenhouse gas mitigation. These recommendations encompass procedures, requirements and tools for the selection and characterisation of the storage site, the assessment of the site, the monitoring of the site, verification of the site and remedial (preventive and corrective) actions for the site.

Expected Impact

The project will provide assurance that geologically stored CO₂ can be reliably monitored and verified, so that the storage qualifies for credits under emissions trading mechanisms.

The developed methods and technologies for CO₂ capture and storage give Europe a competitive advantage in global markets and influence the ability of emerging economies (e.g. Russia, China and India) to reduce their greenhouse gas emissions from burgeoning fossil energy infrastructures.

At the present time, Europe has a leading position in several aspects of CO₂ capture and storage: the Norwegian Sleipner project is a prime example of large-scale geological storage

operations and monitoring. It is believed that a continuing major multinational European effort will maintain this leading edge and will result in further development of this important technology.

Fossil fuels remain important for meeting Europe's energy needs for at least the next several decades. CO₂ReMoVe will have a major impact on the achievement of the Kyoto targets because it will enable the generation of CO₂-free energy to be generated from fossil fuels in the medium term. The development of performance assessment and monitoring methodologies will contribute to the establishment of safety and security guidelines in support of underground CO₂ storage.

The establishment of robust monitoring and performance assessment methods will result in the improved credibility and viability of long-term, large-scale geological storage. It may be predicted that the number of operations in Europe will increase from a single site in 2000, through three in 2004, to around ten in 2010. This is a self-propagating development in the sense that, as more storage sites become operational, more data and expertise will become available. With time, methods will become common practice, cheaper and more robust and reliable.

INFORMATION

Contract number
518350

Instrument
Integrated Project

Total cost
€ 15 million

EC funding
€ 8 million

Coordinator
Ton Wildenborg
Netherlands Organisation for Applied
Scientific Research - NL
ton.wildenborg@tno.nl

Partners
BP - UK
British Geological Survey - UK
Bundesanstalt für Geowissenschaften
und Rohstoffe - DE
Bureau de Recherches Géologiques et
Minières - FR
Central Mining Institute Poland - PL
Det Norske Veritas - NO
Energy Research Centre of the
Netherlands - NL
Etudes et Production Schlumberger - FR
GeoForschungsZentrum Potsdam - DE
Geological Survey of Denmark
and Greenland - DK
IEA Environmental Projects - UK
Imperial College of Science, Technology
and Medicine - UK
Institut Français du Pétrole - FR
Istituto Nazionale di Oceanografia
e di Geofisica Sperimentale - IT
Polish Academy of Sciences - PL
Quintessa - UK
Schlumberger Stavanger Research - NO
SINTEF Petroleum Research - NO
Statoil - NO
Total - FR
Università di Roma 'La Sapienza' - IT
Vattenfall Utveckling - SE
Wintershall - DE

Website
www.co2remove.eu



EU GEOCAPACITY

Objectives

The main objective of the project is to assess the European capacity for geological storage of carbon dioxide (EU GeoCapacity).

The project will include full assessments of a number of hitherto not surveyed countries and updates of previously covered territory. Also a priority is the further development of innovative methods for capacity assessment, economic modelling and site selection criteria. Finally, an important mission is to initiate scientific collaboration with China, a member of the CSLF.

The GeoCapacity project will comprise all or parts of the sedimentary basins suitable for geological storage of CO₂ and located within the EU and the Central and Eastern European new Member States and Candidate Countries. In areas that were part of the GESTCO project completed in 2003, the work will include only supplementary updates.

Assessing European Capacity for Geological Storage of Carbon Dioxide

Key Issues

- Inventory and mapping of major CO₂ emission point sources in 13 European countries (Bulgaria, Croatia, Czech Republic, Estonia, Hungary, Italy, Latvia, Lithuania, Poland, Romania, Slovakia, Slovenia, Spain), and review of four neighbouring states: Albania, Macedonia (FYROM), Bosnia-Herzegovina, Luxembourg) as well as updates for five other countries (Germany, Denmark, the UK, France, Greece);
- conduct assessment of regional and local potential for geological storage of CO₂ for each of the countries involved;
- carry out analyses of source-transport-sink scenarios and conduct economical evaluations of these scenarios;
- provide consistent and clear guidelines for assessment of geological capacity in Europe and elsewhere;
- further develop mapping and analysis methodologies (i.e. GIS and DSS);
- develop technical site selection criteria;
- initiate international collaborative activities with the P.R.China, a CSLF member, with a view to further and closer joint activities.

The project will build upon the basic work and results generated by the GESTCO project which pioneered the development of carbon dioxide emissions and geological storage mapping in Europe, and which has served as an international example.

Technical Approach

The geological surveys and the range of other research partners throughout Europe are in a unique position to carry out this R&D study. The surveys and other state institutes have over decades, and in some instances for more than a century, studied and mapped the distribution and composition of hard rocks and sediments in the subsurface. The project partners thus have access to large amounts of accumulated knowledge of the subsurface geology of Europe obtained from work on mineral exploitation, geothermal studies, and hydrocarbon activities such as seismic mapping and drilling for oil.

These various vintages of maps, other data and previous work will make it possible for the project partners to produce reasonable evaluations of the CO₂ storage capacity of the selected representative study areas.

The GeoCapacity project will focus on countries in eastern, central and southern Europe not previously covered in detail.

This project will provide the data required for the Europe-wide adoption of CCS. The project will focus on applying advanced evaluation techniques (DSS & GIS) and complementing the datasets by emission, infrastructure and storage site mapping as well as undertaking economic evaluations. This will enable source-to-sink matching across Europe. Site selection criteria, standards and methodologies will be created and applied to the project. Locating potential CO₂ storage sites may be essential

INFORMATION

Contract number
518318

Instrument
Specific Technical Research Project

Total cost
€ 3.59 million

EC funding
€ 1.9 million

Coordinator
Niels Peter Christensen
Geological Survey of Denmark
and Greenland - DK
npc@geus.dk

Partners
British Geological Survey - UK
Bundesanstalt für Geologie
und Rohstoffe - DE
Bureau de Recherches Géologiques
et Minières - FR
Czech Geological Survey - CZ
Dionyz Stur State Geological Institute - EL
Ecofys - NL
ENDESA Generación - ES
EniTecnologie - IT
Eötvös Loránd Geophysical Institute of
Hungary - HU
GeoEcoMar - RO
Geoinženiring - SI
Geological Survey of the Netherlands - NL
Geophysical Exploration Company - PL
Institut Français du Pétrole - FR
Institute for Geology and Mining
Engineering - EL
Institute of Geology and Geography - LT
Institute of Geology at Tallinn University
of Technology - LT
Instituto Geológico y Minero de España - ES
Istituto Nazionale di Oceanografie
e di Geofisica Sperimentale - IT
Latvian Environment, Geology
and Meteorology Agency - LV
Polish Academy of Science - PL
Tsinghua University - CN
University of Sofia - BG
University of Zagreb - HR
Vattenfall AB - SE

Website
www.geocapacity.eu



to the emergence of the hydrogen economy. Production of hydrogen will be heavily reliant on fossil fuels, at least in its early development, and will have to consider CO₂ reduction strategies.

The GeoCapacity project will also begin to build towards a framework for international cooperation, especially with other CSLF countries, beginning with China. This will focus on technology transfer to help these countries undertake similar studies, as they perhaps face an even greater challenge to reduce CO₂ emissions, due to their rapidly growing energy demands. This project will be built on east-west and international cooperation, helping us find solutions to a global challenge.



CO₂NET-EAST

Objectives

CO₂NET EAST is a coordination action proposed as a mechanism to involve the new EU Member States and Associated Candidate Countries in the current European CCS networking activities, especially in the existing Carbon Dioxide Knowledge Transfer Network (CO₂NET). This network was initially set up under the EC FP5 Programme, as the leading European CCS networking forum.

CO₂NET EAST will contribute to the European CCS networking by:

- providing membership support to new CO₂NET member organisations from new EU Member States and Associated Candidate Countries in order to help them participate actively in Annual Seminars and other networking activities;
- (co-)organising several CO₂NET events (seminar, workshops) in new Member States and Candidate Countries;
- disseminating knowledge and raising awareness of CO₂ capture and storage technologies in new Member States and Candidate Countries;
- establishing links among CCS stakeholders in new Member States and Candidate Countries, and between them and their partners in other EU countries, using existing networks like CO₂NET or ENeRG as well as links with the Technology Platform for Zero Emission Fossil Fuel Power Plants.

The project is built on East-West cooperation, helping the new Member States to add to the coordination effort to fast-track the development and commercialisation of CCS technology for Europe.

CO₂ capture and storage networking extension to new member states

Key Issues

The Central and Eastern European new Member States and Candidate Countries have reduced emissions of CO₂ dramatically since 1990. This has mainly been the inadvertent result of lower industrial and economic activity following the dissolution of the former Council for Mutual Economic Aid (COMECON, popularly known as the 'East Block') and the subsequent economic changes. This situation might, at least for a few years to come, provide the opportunity for the EU to acquire emission credits through the use of the Kyoto Protocol flexible mechanisms.

In the longer term, however, these new Member States and Candidate Countries will be looking towards rapid development of their economies, modernisation of their industrial sectors, and in a general way striving towards achieving the same standard of living as their neighbours to the west. This cannot be done without an increase in their CO₂ production, creating a need for CO₂ emissions reduction at the same time.

A good example of this situation is Poland, which belongs to the European countries emitting large quantities of CO₂. Today's total emissions are estimated at about 330 Mt/yr, which ranks the country as 6th in the EU25. There has been a steady increase of emissions since 2000, with an exception in 2002. Assuming the present rate of increase, 92% of the 1990 level (EU threshold of the Kyoto Protocol) will have been reached by end-2007. Polish industry will soon be forced to either buy allowances using the emission trading system, or seek other measures to reduce its CO₂ emissions, including CCS.

Moreover, when considering other criteria than the simple volume of CO₂ emissions, the position of some of the new Member States and Candidate Countries is much worse. According to the EEA 8/2005 report 'Greenhouse gas emission trends and projections in Europe

2005', per capita emissions in, for example, the Czech Republic (14t) and Estonia (14t) exceed the EU average (11t in 2003) significantly. CO₂ emissions per kWh of heat and power produced in Poland and the Czech Republic rank among the highest in the world. Slovenia and Croatia are already, or will shortly be, experiencing difficulties in meeting the Kyoto target. The relatively high greenhouse gas emissions per GDP unit indicate that the new EU Member States still have potential to improve in this area and further decrease greenhouse gas emissions. In Candidate Countries the situation is similar.

Technical Approach

CO₂NET EAST will use various means of knowledge transfer, dissemination and public awareness creation, embracing both joint activities with CO₂NET and independent local actions. The most important of them will be:

- co-organisation of a CO₂NET annual seminar in one of the new Member States (Warsaw, Poland, 2008);
- organisation of two regional workshops focused on CO₂ capture and storage (CCS) with the main aim to attract local stakeholders; CO₂ producers, ministries as well as researchers; invitation of CO₂ capture experts from leading European R&D institutions is foreseen, with the help of other CO₂NET members (workshops in Zagreb, Croatia, in 2007 and Bratislava, Slovakia, in 2009 are planned);
- presentations of latest CCS R&D achievements at suitable local events (professional meetings and workshops with focus on CO₂ emissions, climate change, environmental geology, etc.);
- publications in national technical magazines and media;

INFORMATION

Contract number
038946

Instrument
Coordination Action

Total cost
€ 0.323 million

EC funding
€ 0.294 million

Coordinator
Vit Hladik
Czech Geological Survey - CZ
hladik@gfb.cz

Partners
Dionýz Štúr State Geological Institute - SK
Eötvös Loránd Geophysical Institute of Hungary - HU
Geophysical Exploration Company - PL
Tallinn University of Technology - EE
National Institute for Marine Geology and Geocology - RO
Statoil - SE
University of Zagreb - HR

Website
www.co2neteast.rgn.hr

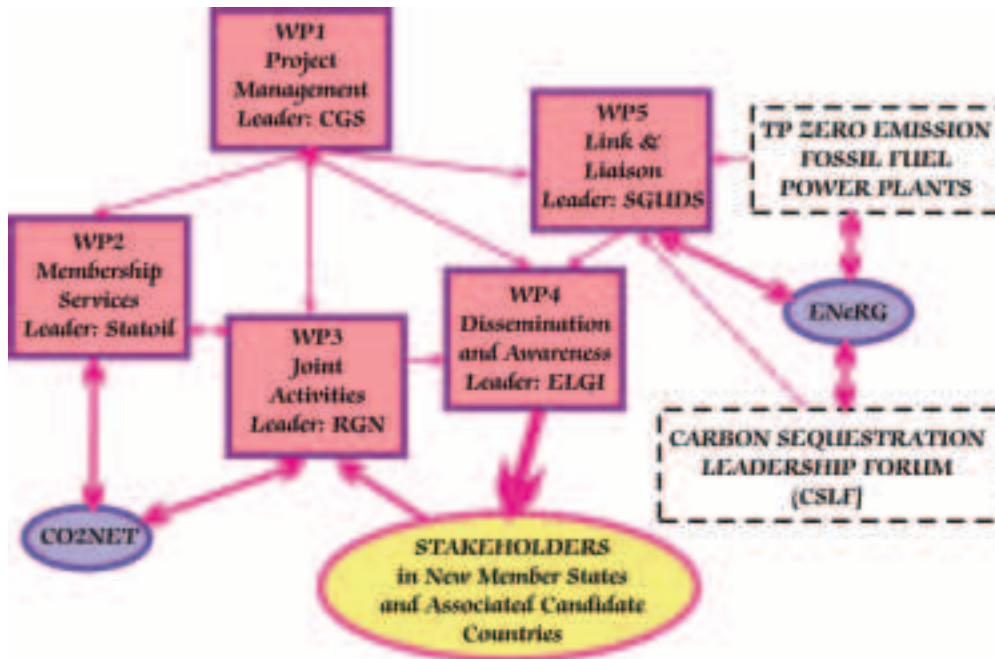

- translation into national languages and publication of the CO₂NET and possibly the ZEP public brochures (both already available in English);
- creation of national websites on CCS (in national languages);
- creation of project website in English (a common website with the ENeRG network at);
- establishing links with the ZEP technology platform;
- establishing links with the ENeRG research network as well as contributing to the work on creating a CCS research strategy within the upcoming EU FP7 Research Programme;
- carrying out liaison with global cooperation activities within the Carbon Sequestration Leadership Forum.

Expected Impact

The CO₂NET EAST project aims at reducing the existing gap between EU-15 and the new EU Member States and Associate Candidate

Countries. If Europe is to fulfil the Kyoto obligations and subsequently be able to carry out the much deeper emission reductions needed, the involvement of all 25 members is necessary. To achieve this goal, targeted effort is required to increase public awareness and disseminate knowledge on CCS in new Member and Candidate Countries.

Presentation of the CO₂ capture and storage technology to all important regional, national and local stakeholders (incl. policy makers), as well as to a broader public as a viable option of climate change mitigation should influence decision-making at national and company level in the sense of:

- further support for R&D activities in the field of CCS;
- integration of the 'zero-emission concept' with the energy policy of governments, regions and big CO₂ emitters;
- preparing the ground for pioneer demonstrations and/or pilot technical installations in new Member States and Associated Candidate Countries in future.



PROJECTS WITH A SUBSTANTIAL INTERNATIONAL DIMENSION



CO₂ Capture Using Amine Processes: International Cooperation and Exchange

CAPRICE

Objectives

The overall objective of CAPRICE is international cooperation and exchange in the area of CO₂ capture, using amine processes, with the long-term aim of contributing to the implementation of these technologies on a large scale. Post-combustion capture using amine processes is generally considered to be the leading capture technology and will be implemented first.

The overall objective is to be achieved through a cooperation between a core team from the ongoing CASTOR Integrated Project and a Canadian consortium linked to the International Test Centre on CO₂ Capture at the University of Regina in Canada. Both projects are recognised by the Carbon Sequestration Leadership Forum (CSLF).

In addition to this leading academic institutions from Russia, China and Brazil will join this research cooperation. The detailed technical project objectives are:

- benchmarking and validation of amine process performance;
- membrane contactor performance validation;
- development of tools for integration into power plants.

Key Issues

- standardisation of descriptive models for amine processes, components and testing procedures;
- performance of different membrane contactors evaluated under realistic conditions;
- ready-to-use tools for integration of amine capture technology with power plants;
- definition of joint CO₂ capture experiments;
- preparation of the ground for a large scale post-combustion CO₂ capture demonstration plant;
- sharing of global resources to develop post-combustion CO₂ capture;
- greatly improved understanding of amine processes for post-combustion CO₂ capture in different environments around the globe, thus facilitating the technology implementation and scale-up;
- contributing to the CSLF objectives from the EU and Canada through concrete cooperation;
- extension of the stakeholder involvement in CO₂ capture technologies to CSLF members Russia, China and Brazil.

Technical Approach

The overall primary objective of CAPRICE is to set up a research cooperation and an exchange of research results in the area of amine processes between the Europe-based CASTOR consortium and the Canada-based International Test Centre consortium. While this brings together the globally leading researchers, a second objective is to extend the cooperation and exchange to third countries with a large application potential for CCS technologies, i.e. Russia, China and Brazil.

The scientific and technological objectives of CAPRICE are:

Benchmarking and validation of amine process performance

Many process and mass transfer models describing solvent processes are currently used. To permit process design and data interpretation, it is essential that these models are properly validated and benchmarked with pilot plant data. The project partners will make available data from their pilot plants to facilitate this. The data will be collected from standard experiments with aqueous MEA-solutions in a uniform format. The benchmarking of modelling tools will result in guidelines for the best approach to process and mass transfer models for CO₂ capture. Corrosion aspects will also be considered through guidelines for corrosion monitoring and materials selection.

INFORMATION

Contract number
38974

Instrument
Specific Technical Research Project

Total cost
€ 1.14 million

EC funding
€ 0.38 million

Coordinator
Paul Feron
Netherlands Organisation for Applied
Scientific Research - NL
paul.feron@tno.nl

Partners
Alberta Research Council - CA
E.ON - UK
Dong Energy - DK
Vattenfall AS - SE
Energy INet - CA
Institut Français du Pétrole - FR
International Test Centre on CO₂ Capture - CA
Norwegian University of Science
and Technology - NO
Topchiev Institute of Petrochemical
Synthesis - RU
Tsinghua University - CN
UNIFACS - BR
University of Regina - CA
University of Stuttgart - DE

Validation of membrane contactor performances

Membrane contactors are expected to contribute towards the reduction of the investment and operational costs of solvent processes. It is however essential to have realistic estimates for their mass transfer performances in order to assess their potential for both absorption and desorption. These performances need to be known for a variety of commercially available porous membranes such as polypropylene and polytetrafluorethylene and developmental membranes for high-temperature applications.

Development of tools for capture plant integration into power plants

Post-combustion CO₂ capture is an add-on technology for conventional power plant and power plant designs. The optimal integration of the capture process with the power plant is necessary to ensure a low energy requirement for CO₂ capture, but it is also needed in order to reduce the investment costs of the interfacing. Engineering tools are required to optimise heat integration. In addition to this, the gas path integration – including the interfacing with the flue gas desulphurisation – is needed, particularly for coal fired power stations.





Cooperation Action with CCS – China-EU

COACH

Objectives

The objective of COACH is to start a strong and durable cooperation between Europe and China to respond to the fast-growing energy demands of the P.R.China. Based on European technologies, it will prepare the ground for implementation of large-scale polygeneration energy facilities and including options for coal-based electric power generation, as well as production of hydrogen and possibly synthetic fuels and provisions for heat integration with surrounding industries. In this endeavour CO₂ capture and permanent geological storage – including use for enhanced oil or gas recovery – constitute an inherent and decisive prerequisite. As such, COACH addresses topics of particular interest to developing countries and refers to the call identifier FP6-2005-Energy-4, Priority 6.1.3.2.6. Addressing polygeneration schemes, COACH will thus refer to the FP6/IP DYNAMIS project. COACH will also draw upon other ongoing projects, in particular GeoCapacity.

Key Issues

COACH will address three issues: coal gasification for appropriate coal-based polygeneration schemes combined with carbon capture and storage; identification of reliable geological CO₂ storage capabilities in China; societal anchorage, including legal, regulatory, funding and economic aspects, and public issues.

To reach these objectives, COACH comprises four work packages, co-led by European and Chinese partners, addressing respectively knowledge-sharing and capacity-building issues, the identification of appropriate CO₂ capture and storage technologies, and providing recommendations and guidelines for implementation. A fifth work package is dedicated to the overall management of the project, and a final work package implements the supervision, monitoring and reporting of EU-China MoU activities.

To operate those work packages and achieve the above-stated objectives, COACH involves 20 participants, among whom 12 European partners from the public and private sectors (research, academia, industry, including one SME) from five different Member States/Associated States, as well as eight Chinese partners, among whom two companies and five RTD providers.

- transformation of the main results into techno-economic criteria pertaining to technology, site locations (plant and CO₂ storage sites), size and stakeholders;
- conceptual studies and planning of a large-scale facility, subject to the scenario;
- validation of the handling and storage options for the CO₂ – including alternative use of the CO₂ (e.g. for EOR/EGR);
- identification of financing mechanisms, legal and regulatory frameworks as well as the environmental and public acceptance issues;
- translation of main results into topical policy documents;

Technical Approach

Assessment and ranking of candidate options (technologies, policy, societal) that are or may become viable within a coal-based scenario for China on polygeneration and carbon capture and storage. This includes:

- viability assessment (studies) subjected to the vision of a realistic and economically sound route for polygeneration linked with carbon capture and storage schemes in China;



INFORMATION

Contract number
38966

Instrument
Specific Technical Research Project

Total cost
€ 2.62 million

EC funding
€ 1.50 million

Coordinator
François Kalaydjian
Institut Français du Pétrole - FR
francois.kalaydjian@ifp.fr

Partners
Air Liquide - FR
Alstom Power - UK
Atanor - FR
BP International - UK
Etudes et Productions Schlumberger - FR
Geological Survey of Denmark and Greenland - DK
Greengem - CN
Institute of Engineering Thermophysics, Chinese Academy of Sciences - CN
Kungliga Tekniska Högskolan - SE
Natural Environment Research Council - British Geological Survey - UK
PetroChina - CN
Shell International Renewables - NL
SINTEF Energiforskning - NO
Statoil - NO
The Administrative Centre for China's Agenda 21 - CN
Thermal Power Research Institute - CN
Tsinghua University - CN
Zhejiang University - CN

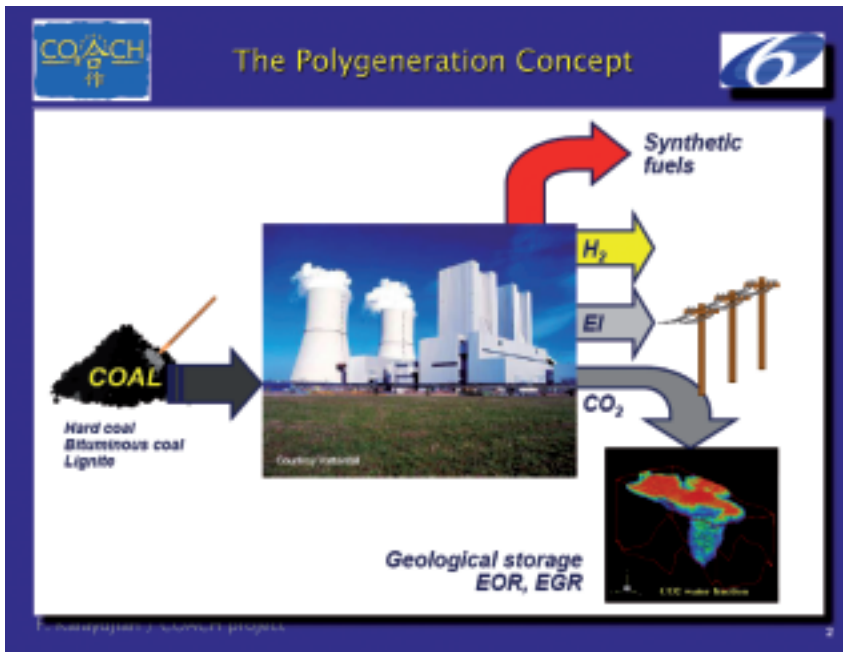

- provision of a roadmap for large-scale coal-based polygeneration with carbon capture and storage in China on technical, economic and societal terms – including permits and how funding can be syndicated in China, and how a subsequent large-scale demonstrator could be generally anchored in society in the context of public acceptance.

COACH includes investigation and optimisation of applicability of large-scale polygeneration schemes in a Chinese context with integrated CO_2 management techniques. The project will build on the efforts obtainable from prior FP6 projects for achieving the technological and economic targets of CO_2 capture and storage. However as underground storage, including the management system for CO_2 , is assumed to entail high capital investment, large quantities of CO_2 would be required to justify the capital expense (CAPEX). Therefore a demonstration

plant must be sized and sited accordingly and this, in turn, is prone to apply to hydrogen-fuelled gas turbines that have to be developed or adapted for such duty. Most likely these turbines will be in the range of the present state-of-the-art industrial gas turbines.

It is not clear at this stage whether, in the Chinese context, the optimum route to carbon capture and storage together with production of hydrogen or liquid fuels is IGCC-based. Because of the large (and rapidly growing) base of modern coal-based power generation plants, especially supercritical generating, there will be a long future for these plants and for consideration of retrofit capture. Technologies such as oxyfuel combustion and chemical looping in combustion processes will also be assessed.

International Cooperation Actions on CO₂ Capture and Storage

INCA-CO₂

Objectives

This Specific Support Action, InCA-CO₂, aims at strengthening European excellence and enhancing the technical competitiveness of Europe in the area of CO₂ Capture and Storage (CCS), by:

- providing support to European stakeholders for international fora such as the Carbon Sequestration Leadership Forum (CSLF);
- establishing international relations with international projects and programmes (the USA, Canada, Japan, Australia) to exchange information on past and ongoing projects, and identify opportunities for future cooperation;
- analysing new information on CCS and providing a coherent view on international activities for input into policy.

The consortium is composed of seven research institutes, key players in the coordination of past and ongoing research projects, actively supported by four industrial partners representing different sectors of CO₂ activities.

Key Issues

Established by the U.S. State Department and DOE in February 2003, the Carbon Sequestration Leadership Forum (CSLF) coordinates data gathering, R&D and joint projects to advance the development and deployment of carbon capture and storage technologies worldwide. CSLF held its first ministerial-level meeting on carbon sequestration in June 2003. High-level representatives from 14 countries, the European Commission, and over 400 members of the international energy, business and government communities participated and signed the CSLF charter.

Goals

- facilitate the development of technologies for CO₂ separation, capture, transport and storage;
- spur global adoption of technologies;
- identify and address capture and storage issues;
- international resources will be leveraged through information sharing and joint participation in projects;
- focus the world's best minds on the most challenging problems.

Technical Approach

In order to achieve its objectives, InCA-CO₂ will address the following topics:

- actions in support of joint or common initiatives and programmes, in particular EU collaboration with international partners such as the DOE and particularly within the CSLF. The project will act as strategic support ('secretariat') to the European co-chairs of the CSLF and will also be able – on behalf of the EU - to carry out the duties of the currently vacant CSLF lead position in charge of the 'Stakeholder Development Task Force';
- the work will be based on the know-how of partners who are involved in:
 - ongoing national, FP 5 and FP 6 projects;
 - international benchmarking of capture technologies, and of tools and methodologies for storage site qualification and risk assessment (NoE's);
 - the well-established European CO₂NET2, which has a membership in excess of 50 companies, R&D institutes and other stakeholders.

INFORMATION

Contract number
513535

Instrument
Specific Support Action

Total cost
€ 0.709 million

EC funding
€ 0.445 million

Coordinator
Pierre Le Thiez
Institut Français du Pétrole - FR
pierre.lethiez@ifp.fr

Partners
BP International Limited - UK
British Geological Survey - UK
Bureau de Recherches Géologiques et Minières - FR
Geological Survey of Denmark and Greenland - DK
Istituto Nazionale di Oceanografie
e di Geofisica Sperimentale - IT
Netherlands Organisation for Applied
Scientific Research - NL
SINTEF Energiforskning - NO
Statoil ASA - NO
Vattenfall AB - SE



The project duration will be three years and will also allow for the inclusion of any other relevant future EU FP6 CCS project group. The project will be flexible enough to take into account any relevant international event.

LIST OF COUNTRY CODES

Code	Country	Code	Country
DZ	Algeria	LV	Latvia
AT	Austria	LI	Liechtenstein
BY	Belarus	LT	Lithuania
BE	Belgium	LU	Luxembourg
BG	Bulgaria	MT	Malta
CA	Canada	MA	Morocco
CL	Chile	NL	The Netherlands
CN	China	NO	Norway
CY	Cyprus	PS	Palestinian territory
CZ	Czech Republic	PY	Paraguay
DK	Denmark	PL	Poland
EG	Egypt	PT	Portugal
EE	Estonia	RO	Romania
FI	Finland	RU	Russia
FR	France	SK	Slovakia
DE	Germany	SI	Slovenia
EL	Greece	ZA	South Afrika
HU	Hungary	ES	Spain
IS	Iceland	SE	Sweden
IN	India	CH	Switzerland
IE	Ireland	TH	Thailand
IL	Israel	TN	Tunesia
IT	Italy	TR	Turkey
JO	Jordan	UA	Ukraine
KE	Kenia	UK	United Kingdom
LB	Lebanon	US	United States

European Commission

EUR 22574 – CO₂ Capture and Storage Projects

Luxembourg: Office for Official Publications of the European Communities

2007 – 51 pp. – 21.0 x 29.7 cm

ISBN 92-79-03724-2

ISSN 1018-5593

SALES AND SUBSCRIPTIONS

Publications for sale produced by the Office for Official Publications of the European Communities are available from our sales agents throughout the world.

You can find the list of sales agents on the Publications Office website (<http://publications.europa.eu>) or you can apply for it by fax (352) 29 29-42758.

Contact the sales agent of your choice and place your order.

This publication is a compilation of synopses of the projects funded under the Sixth Framework Programme in the field of CO₂ capture and storage. It gives a comprehensive view of European funded activities in this area. For each project, basic information is provided with regard to the scientific and technical scope, expected impact, the participating organisations and contact points.

The projects described in the brochure will hopefully provide guidance for future European research, in particular that carried out under the Seventh Framework Programme on CO₂ capture and storage and clean fossil fuels more generally.