



S M A R T **G** R I D S

Customer Needs and Opportunities Workshop Working Group 2: (Operations)

Dr. Bernd Michael Buchholz

Siemens AG

Director

Bernd.Buchholz@Siemens.com

Network operations – Customer needs and opportunities



SMARTGRIDS

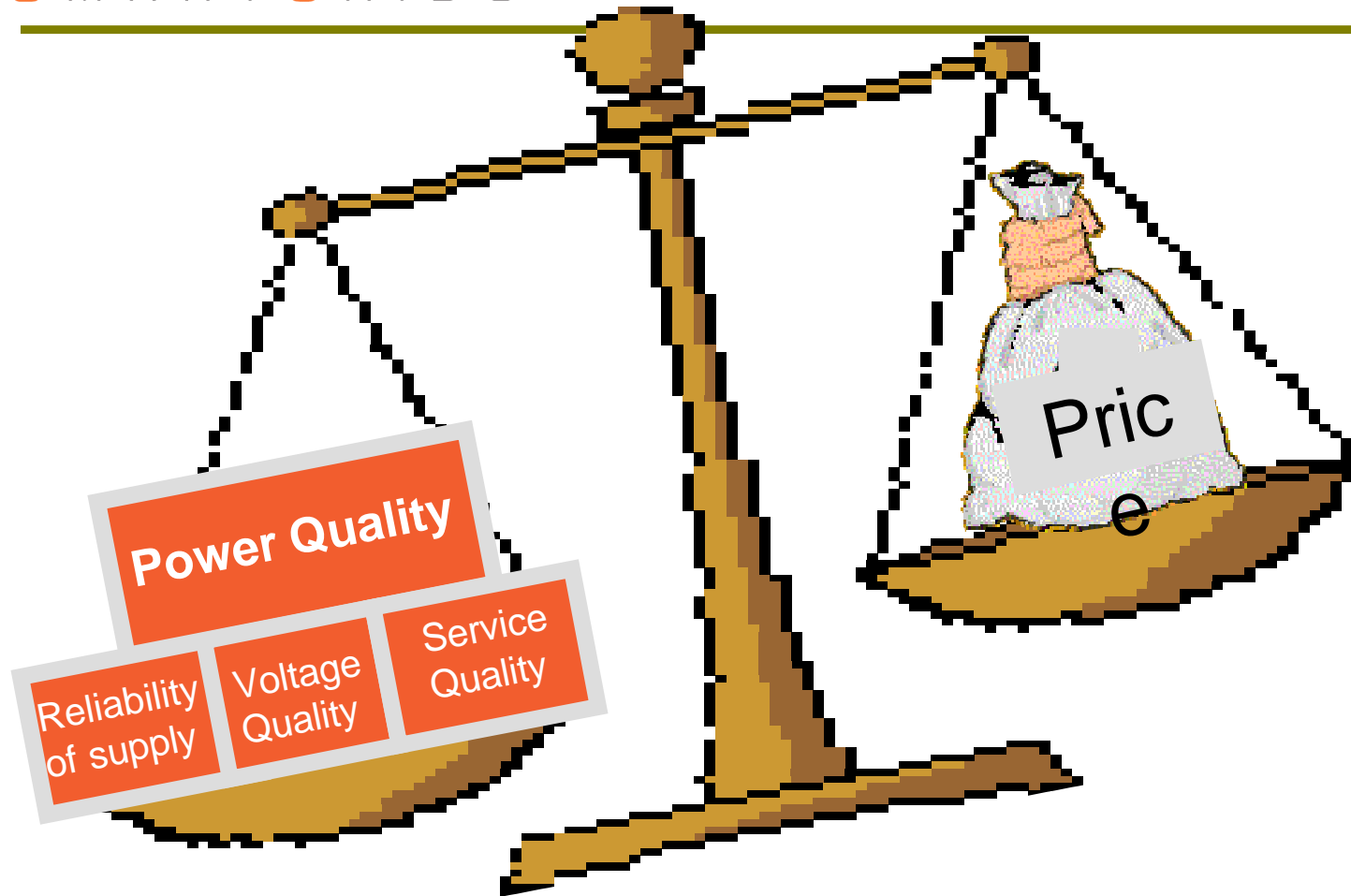

How can the smart grid concept influence the customer's expectations?



Impact on electricity price

S M A R T G R I D S

Average electricity price structure
of Germany without state taxes

(VDEW 2005)

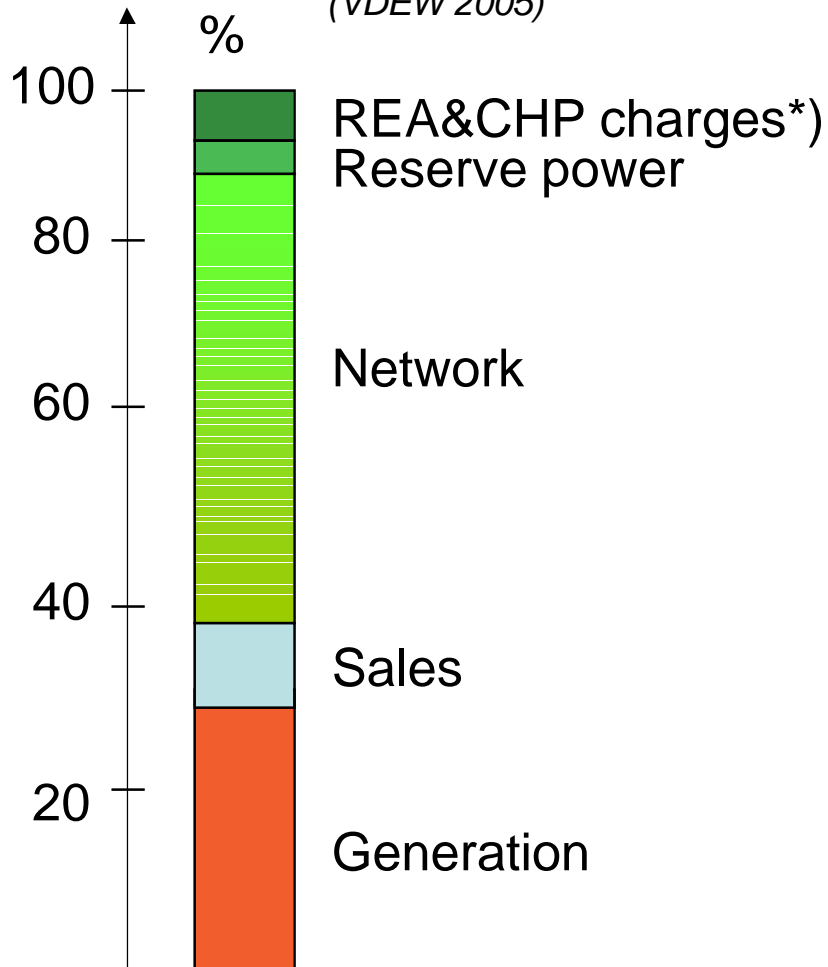

Needs

Equal market conditions for all power producers -
Incentives for quality, not for quantity
Minimize reserve power through precise prediction, scheduling and on-line schedule control (VPP concept)

Opportunities

Dynamic tariffs
Incentives for Demand Side Management
Lower charges for network use due to local generation
Free market for ancillary services

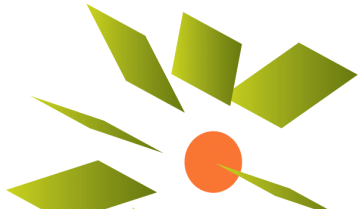

Impact on reliability of supply

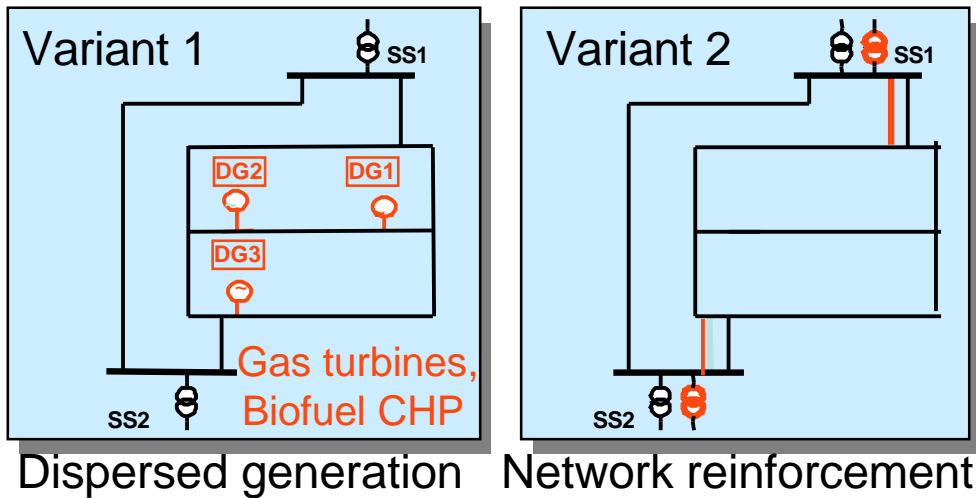

Needs

Ensuring certain technical availability of dispersed and renewable generation plants

Reserve power to compensate fluctuations

“Fault ride through” with definite level of short circuit currents

Opportunities

Islanding of distribution networks with significant share of dispersed generation in cases of large system disturbances

Avoidance of network reinforcement

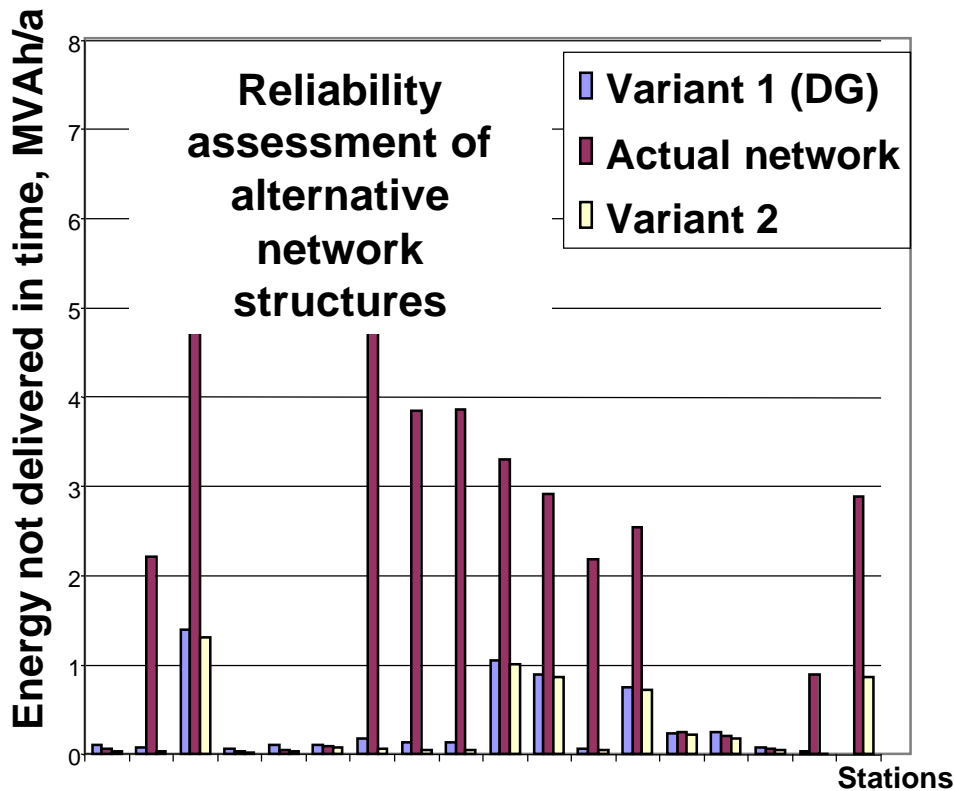



SMARTGRIDS

Impact on voltage quality

11 kV network
Peak: 3.4 MW
Installed DG*)
4.2 MW

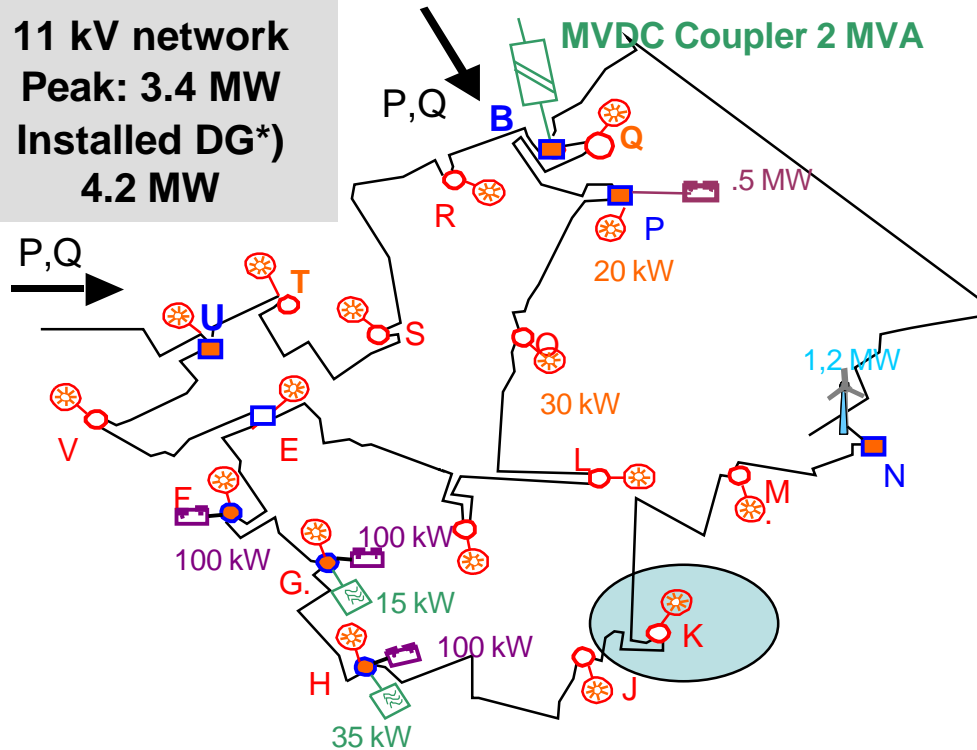

Needs

Filtering of harmonics

Fast compensation of voltage drops and flicker due to intermitting power generation

Balancing of reactive power in a given framework of power factors

Opportunities

Local voltage and reactive power control by dispersed generation units

No need for tap changer control

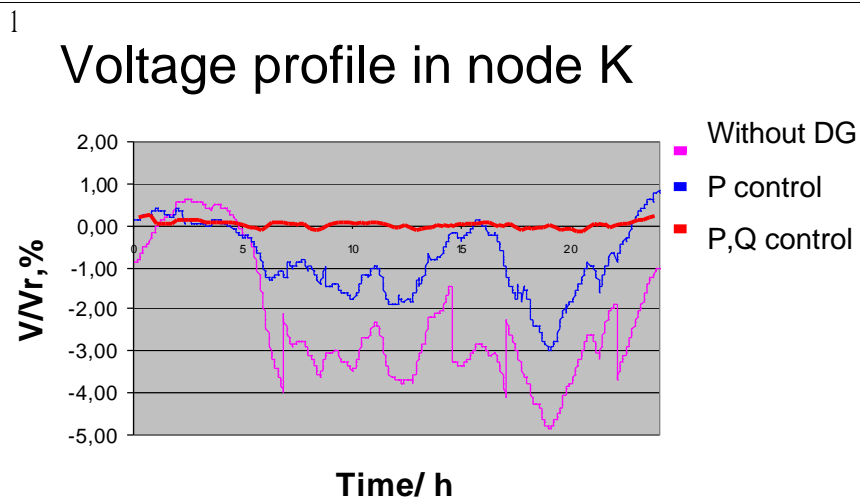

*) DG – Dispersed generation & storage & MVDC

Service quality in the environment of multiple players

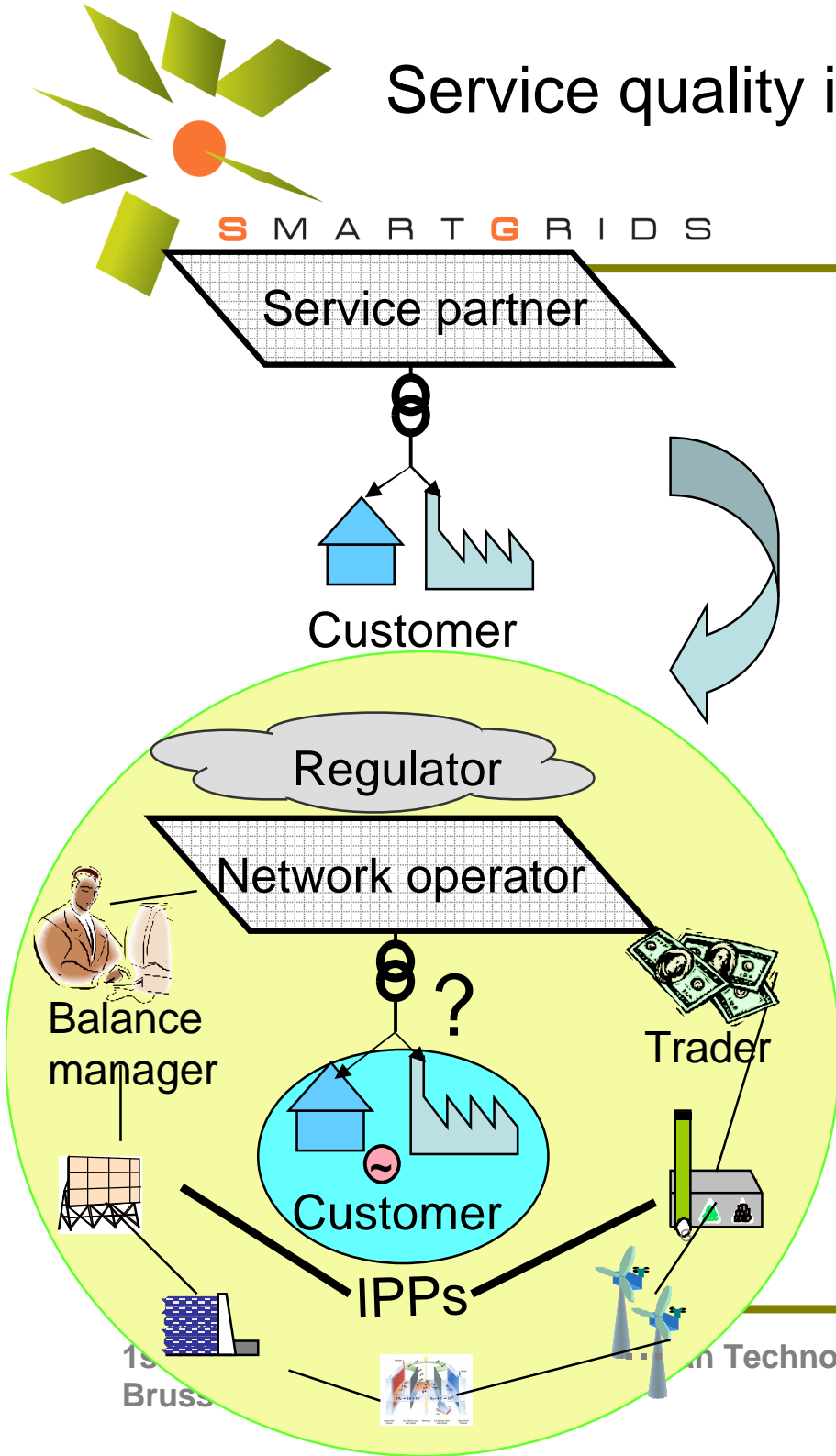

Needs

Definite responsibilities for all services, e.g.:

- Network access
- Response on requests
- Electricity supply contracts
- Disturbance elimination
- Meter reading and billing
- Tariff information

Opportunities

Contract management between all players ensuring fixed responsibilities for customer services.

Customer Hot- Line