

**REGULATORY ASPECTS OF ACCESS TO MOBILE NETWORK
INFRASTRUCTURES AND NETWORK INTELLIGENCE**

Final Report

July 2001

**The opinions expressed in this Report are those of the authors and
do not necessarily reflect the views of the European Commission**

© ECSC – EC – EAEC, Brussels – Luxembourg 2001



**REGULATORY ASPECTS OF ACCESS TO MOBILE NETWORK
INFRASTRUCTURES AND NETWORK INTELLIGENCE**

Final Report

Content

<u>EXECUTIVE SUMMARY</u>	I
<u>1. INTRODUCTION</u>	1
<u>1.1 Study Aims</u>	1
<u>1.2 Approach</u>	1
<u>2. ACCESS IN THE 2G ENVIRONMENT</u>	3
<u>2.1 Regulatory Situation</u>	3
<u>2.2 Service Provider Access Trends</u>	4
<u>3. TRANSITION TO A MULTIMEDIA MARKET</u>	5
<u>3.1 Overview</u>	5
<u>3.2 Market Drivers</u>	5
<u>3.2.1 Overview</u>	5
<u>3.2.2 Economic</u>	6
<u>3.2.2.1 Operator Investment Costs</u>	6
<u>3.2.2.2 Macro-economic Performance</u>	8
<u>3.2.3 Social</u>	9
<u>3.2.4 Regulation</u>	9
<u>3.2.4.1 Licensing - Intensity of Competition</u>	9
<u>3.2.4.2 Regulatory Powers</u>	10
<u>3.2.5 Technology</u>	11
<u>3.3 Potential Markets and Services</u>	13
<u>3.3.1 Overview</u>	13
<u>3.3.2 Voice</u>	14
<u>3.3.3 Data</u>	14
<u>3.3.4 Service Value/Pricing</u>	15
<u>3.4 Potential Service Providers</u>	16
<u>3.4.1 Overview</u>	16
<u>3.4.2 Telecoms Services Providers</u>	17
<u>3.4.3 Content Owners</u>	17



<u>3.4.4</u>	<u>Value Added Mobile Service Providers</u>	18
<u>3.5</u>	<u>Possible Value Chains</u>	18
<u>4.</u>	<u>ACCESS SCENARIOS</u>	22
<u>4.1</u>	<u>Overview</u>	22
<u>4.2</u>	<u>Network Facilities</u>	22
<u>4.3</u>	<u>Service Provider</u>	23
<u>4.3.1</u>	<u>Overview</u>	23
<u>4.3.2</u>	<u>Telecoms Services Providers</u>	23
<u>4.3.2.1</u>	<u>Definition and Service Offering</u>	23
<u>4.3.2.2</u>	<u>Likely Access Requirements</u>	24
<u>4.3.2.3</u>	<u>Potential Access Problems</u>	24
<u>4.3.3</u>	<u>Content Owners</u>	25
<u>4.3.3.1</u>	<u>Definition and Service Offering</u>	25
<u>4.3.3.2</u>	<u>Likely Access Requirements</u>	25
<u>4.3.3.3</u>	<u>Potential Access Problems</u>	26
<u>4.3.4</u>	<u>Value Added Mobile Service Providers</u>	26
<u>4.3.4.1</u>	<u>Definition and Service Offering</u>	26
<u>4.3.4.2</u>	<u>Likely Access Requirements</u>	26
<u>4.3.4.3</u>	<u>Potential Access Problems</u>	26
<u>4.4</u>	<u>Market</u>	27
<u>4.4.1</u>	<u>Overview</u>	27
<u>4.4.2</u>	<u>Low Revenue Market - Vertical Integration</u>	28
<u>4.4.2.1</u>	<u>Market Situation and Player Motivation</u>	28
<u>4.4.2.2</u>	<u>Potential Access Problems</u>	28
<u>4.4.2.3</u>	<u>Regulatory Issues</u>	29
<u>4.4.3</u>	<u>Low Revenue Market - Horizontal Integration</u>	29
<u>4.4.3.1</u>	<u>Market Situation and Player Motivation</u>	29
<u>4.4.3.2</u>	<u>Potential Access Problems</u>	30
<u>4.4.3.3</u>	<u>Regulatory Issues</u>	30
<u>4.4.4</u>	<u>High Revenue Market - Vertical Integration</u>	31
<u>4.4.4.1</u>	<u>Market Situation and Player Motivation</u>	31
<u>4.4.4.2</u>	<u>Potential Access Problems</u>	31
<u>4.4.4.3</u>	<u>Regulatory Issues</u>	32
<u>4.4.5</u>	<u>High Revenue Market - Horizontal Integration</u>	32

<u>5.</u>	<u>CONCLUSIONS AND RECOMMENDATIONS</u>	33
<u>5.1</u>	<u>Nature of Market</u>	33
<u>5.2</u>	<u>Commercial Environment</u>	33
<u>5.3</u>	<u>Regulation</u>	34
<u>5.3.1</u>	<u>Potential Access Issues</u>	34
<u>5.3.1.1</u>	<u>Nature and Context</u>	34
<u>5.3.1.2</u>	<u>Risks of Intervention</u>	34
<u>5.3.1.3</u>	<u>Risks of Non-intervention</u>	34
<u>5.3.1.4</u>	<u>Conclusion</u>	35
<u>5.3.2</u>	<u>Common Regulatory Framework Implementation</u>	35
<u>5.3.3</u>	<u>Dispute Resolution</u>	35
<u>5.4</u>	<u>Risk and Reward in Value-added Markets</u>	36
<u>APPENDICES</u>		
<u>I.</u>	<u>ORGANISATIONS INTERVIEWED</u>	37
<u>II.</u>	<u>INTERVIEW PROGRAMME ANALYSIS</u>	39
<u>II.1</u>	<u>Overview</u>	39
<u>II.2</u>	<u>The Future Value Chain</u>	39
<u>II.3</u>	<u>Future Value Added Services</u>	40
<u>II.3.1</u>	<u>Overview</u>	40
<u>II.3.2</u>	<u>Importance of Content</u>	41
<u>II.3.3</u>	<u>Carrier-Selection/Preselection</u>	41
<u>II.3.4</u>	<u>Technology</u>	41
<u>II.4</u>	<u>3G Market Development – Critical Success Factors</u>	42
<u>II.5</u>	<u>The Nature and Role of Regulation</u>	43
<u>II.5.1</u>	<u>Overview</u>	43
<u>II.5.2</u>	<u>Role of NRAs</u>	43
<u>II.5.3</u>	<u>SMP and Market Definition</u>	44
<u>II.5.4</u>	<u>Independent Regulators Group</u>	44
<u>II.5.5</u>	<u>3G Timetable</u>	44
<u>II.5.6</u>	<u>Fixed versus Mobile Telecoms Regulation</u>	44
<u>II.5.7</u>	<u>Handset Subsidisation</u>	45
<u>II.5.8</u>	<u>Requests for Access</u>	45
<u>II.5.9</u>	<u>Types of Access</u>	46

<u>II.5.10</u>	<u>Cost Orientation and Non Discrimination</u>	46
<u>II.5.11</u>	<u>Licensing and Spectrum</u>	46
<u>II.5.12</u>	<u>Dispute Resolution</u>	47
<u>II.5.13</u>	<u>Network Financing</u>	47
<u>II.5.14</u>	<u>Infrastructure</u>	48
<u>II.5.15</u>	<u>Role of the European Commission</u>	49
<u>III.</u>	<u>MNO-SP AGREEMENTS</u>	51
<u>IV.</u>	<u>STANDARDISATION</u>	54
<u>V.</u>	<u>MOBILE TELECOMS REGULATION</u>	56
<u>V.1</u>	<u>Overview</u>	56
<u>V.2</u>	<u>Member State Regimes</u>	56
<u>V.3</u>	<u>Non-EU Approaches</u>	59
<u>V.3.1</u>	<u>Overview</u>	59
<u>V.3.2</u>	<u>New Zealand</u>	59
<u>V.3.3</u>	<u>Australia</u>	59
<u>V.3.4</u>	<u>Hong Kong</u>	60
<u>V.3.5</u>	<u>USA</u>	61
<u>V.4</u>	<u>Common Regulatory Framework</u>	61
<u>V.4.1</u>	<u>Overview</u>	61
<u>V.4.2</u>	<u>SMP and Market Analysis</u>	62
<u>V.4.3</u>	<u>NRA “Toolkit”</u>	63
<u>VI.</u>	<u>CURRENT MNOS (AFTER 3G LICENCING PROCESS)</u>	65
<u>VII.</u>	<u>GPRS AND 3G (UMTS) SERVICE LAUNCH DATES</u>	68



EXECUTIVE SUMMARY

Study Coverage

The study's overall aim was to provide the European Commission with recommendations and guidelines for an approach to the regulatory treatment of access to **future mobile network infrastructures** and **network intelligence**

Within the context of this overall aim, the study's objectives were to:

- describe the 'drivers of change' likely to determine the market's development
- define the potential types of access required by companies (without networks) looking to enter the market
- describe current and planned (draft) access rules within the EU, and the nature and experiences of such regulation in liberalised non-EU markets
- generate market development scenarios, and assess their implications for regulators, particularly in relation to practices which could restrict competition
- develop recommendations for an EU regulatory approach, including dispute resolution.

The study takes as its core assumption that regulation's role is to facilitate the development of a competitive market for mobile telecommunications services to the benefit of personal and corporate end users rather than penalise or encourage any particular type of market player.

Although the report examines possible market and access scenarios, they are not predictions of how the market is likely to, or should, develop. Clearly, if the market develops in a competitive manner, there will be no need/basis for regulatory intervention.

The study was carried out between January and May 2001 and involved a comprehensive desk research programme supplemented by in-depth interviews with 82 organisations, a summary of whose opinions and attitudes is given in Appendix II.

Access in the 2G Environment

In the current 2G voice-centric mobile market, access to (mobile) networks has been on the basis of commercial negotiation, with disputes handled under the Interconnection Directive. Despite disputes, Service Providers (SPs) are active on mobile networks (see Appendix III). There also appears to be an increasing willingness on behalf of Mobile Network Operators (MNO) to provide third parties with access to their networks on the basis of commercially negotiated 'win-win' agreements.

The market has recently seen the introduction of a new concept - the Mobile Virtual Network Operator (MVNO). However, this has been confused by a lack of a common definition and understanding of what it is to be an MVNO. There appears to be consensus that an MVNO does own some infrastructure and offers mobile subscriptions and services, but that it does not have spectrum. It is the nature and extent of the owned infrastructure, which is 'required' for an SP to be considered an MVNO that differs. A common minimum requirement appears to be ownership of the mobile switch and billing functionality. Given



this, 'full' MVNO deals seem limited today to those of Sense in Sweden and Denmark, and Tele 2 with Sonofon in Denmark.

From an access perspective, it is more sensible to talk about an increase in 'MVNO-type' agreements (see Appendix III), with an emphasis on Enhanced Service Provider (ESP)-type arrangements, such as Virgin Direct's joint venture with One2One in the UK. Although such ventures are often associated with MVNOs, this is, in reality, not the case.

Post-2G Market Development

Market Drivers

The move from supplying current network-based voice-centric services to value-added multimedia services represents a 'revolution' for MNOs. This change from being principally sellers of a (price-driven) commodity - air time - to providers of value-added multimedia services, will cause MNOs to act and compete in a fundamentally different fashion. Furthermore, this change is taking place - and is likely to continue to take place - in a business environment characterised by *risk* and *uncertainty*.

MNO strategies and philosophies will be strongly influenced by the need to recover the costs associated with the move to 3G networks, in terms of the acquisition of licences (in some Member States), which has led to significant increases in debt levels, and future expenditure on network build out and marketing. Although levels of expenditure vary by Member State, financial pressures will be exacerbated by higher levels of competition than in the 2G environment, with the overall number of MNOs in the EU having risen from 52 to 66 as at the end of May 2001.

The uncertainty surrounding the depth and duration of the current slowdown in major global economies is also likely to threaten further MNOs' ability to achieve a return on investment (within commercially acceptable timescales).

Although the speed of take up of services will be 'regulated' by economic growth, the actual 'base' levels of demand for post-2G services are still far from certain, particularly in relation to the nature of services, which consumers will purchase and the size of premium, if any, they are prepared to pay for (what the supply-side considers to be) 'value added' services, as well as the willingness of users in many Member States to accept a reduction in MNO subsidisation of mobile devices.

The proposed new Common Regulatory Framework will provide National Regulatory Authorities (NRA) with the power to impose significant obligations on MNOs with Significant Market Power (SMP). Although the proposed Framework's flexibility allows NRAs to address new market problems, there are concerns over consistency in its interpretation and application. Some interviewed organisations stressed the Commission's potential to *facilitate* the success of the 3G market by focusing attention on the fact that if manufacturers and MNOs are not allowed to build the market's momentum, talk of regulatory approaches will be academic.

At the highest level, technology is a market facilitator, rather than a driver. However, the real significance of technology lies in the challenge it presents to MNOs' traditional business models, with the *technical* transition, from *circuit-switched* to *packet-driven* data in high-speed



IP-based (2.5G and 3G) networks enabling, and acting as a catalyst for, key changes in the nature and provision of services:

- the IP “always-on” environment will offer any time, any place connectivity, with end users able to specify their requirements
- the single service voice world will proliferate into various services and service bundles, multiple business models and revenue sharing
- customer billing will shift from cost per unit of time to payment per amount of data downloaded or according to the value-added provided to the end user.

As a consequence of these changes, MNOs will move from a 2G environment where they have been able to enjoy almost 100% of a relatively simple value chain to a more extended post-2G world where the *non-voice* element of the multimedia value chain will be dominated by *enablers* – in particular, content providers and content aggregators. In such a value chain an MNO, which assumes a transport role only, would see its share of value added decrease as the value (added) of the service increases. With the need to justify investment, an MNO’s *overall* revenue will have to be higher (than that without investment), making vertical integration to capture more value added a commercially sensible strategy.

Potential Service Providers

An SP is a business without a network, which requires access to an MNO’s infrastructure to deliver its offering to the (mobile) market.

In the current 2G world, all SPs in practice offer a variation on MNOs’ ‘basic’ voice telephony service, and fall into three broad categories: air time resellers, ESP and ‘full’ MVNO. In a post-2G environment, it seems unlikely that the air time reseller model will remain viable, and SPs are likely to fall into three main categories:

- *telecoms services providers*, which could include fixed operators looking to offer an integrated fixed/mobile service, mobile telecoms operators, which would effectively compete directly with their ‘host’ MNOs, and content owners, such as large retail chains, which would seek to leverage their brand and customer bases
- *content owners*, which would wish to use MNO networks as an additional distribution channel to their customer bases
- *value added mobile service providers*, which would look to use elements of the network to develop value added services.

Access Scenarios

Overview

Potential access issues in a post-2G environment can be considered in terms of the core network facilities likely to be required by SPs, specific types of possible SPs, and overall market (supply-side) developments, which could challenge the regulatory ‘status quo’ established by the (proposed) Common Regulatory Framework.



Network Facilities

Whilst there appears to be general agreement that access is not a technical (engineering) problem, there are still a number of potential structural 'bottlenecks' in that *they are unique* to a network, and cannot be replicated (by a third party). This most significant of these is likely to be information on subscribers, such as device/subscriber location data, security (authentication) data, and micro-billing facilities/billing information.

Service Providers

Telecoms Services Providers (TSP) would provide their customers with mobile devices and could, in theory, offer a complete range of voice, data and multimedia services. Given this, they would, in effect, compete directly with the 'host' network in some or all service areas, although they are more likely to focus on a particular market segment or series of niches. All, however, are likely to offer a 'basic' voice service.

The nature of access required could range from 'complete' infrastructure and network intelligence for an ESP, such as a large retail organisation, to 'infrastructure only' for companies adopting a 'full' MVNO business model.

Possible disputes are likely to focus on failures to agree commercial terms, as there will be no incentive for MNOs to conclude agreements, which would not allow them a share of a TSP's value added, or which, in practice, could reduce their own earnings potential. Underlying such disputes is likely to be MNO concern about striking deals, the terms of which (could) then become the basis for subsequent negotiations under a potential non-discrimination obligation, should they be designated as having SMP (in that particular market).

A range of *content owners*, such as retail outlets and banks, may wish to sell/provide their content or service to their existing customer bases via the mobile sales channel. As a result they are likely to need access to location data (for m-advertising services), and authentication/security and billing information (for m-commerce and m-banking services). Although not strictly an access issue, it will be also commercially important for either a content owner's service to be easily found on a 'host' MNO's mobile portal and/or for customers to be able to access a content owner's own mobile portal from a 'host' MNO's mobile portal. Such 'non-access' access will be particularly important for competing mobile portals.

For non-competing content owners, it seems unlikely that access will be a major concern. Since MNOs cannot replicate such services, negotiations are likely to relate to transport and data costs. However, as with TSPs, MNOs may be concerned about striking deals, which (could) then become the basis for subsequent negotiations under a possible non-discrimination obligation.

A potentially new type of SP could develop around MNOs' network facilities, particularly location data. Such SPs are likely to want to provide their service to an, or all, MNOs' customers. Given this, such operators would, in practice, be SPs to MNOs. Access problems are therefore likely to focus on failure to agree commercial terms, since MNOs are likely to wish to secure a share of an SP's value added in return for providing access to both customers and customer data.



Market Development

There is uncertainty about the development of the post-2G market. In order to identify possible regulatory implications, a number of extreme scenarios were developed, each of which would pose challenges to NRAs.

Under a scenario where MNOs have to operate in a low revenue market, *vertical integration*, such as the acquisition of an MNO by a consortium of upstream value chain players, could lead to a reduction in wholesale capacity for SPs. An NRA would then be faced with a major policy issue in relation to the ownership of mobile networks, with almost all possible responses likely to lead to supply-side consolidation, thereby increasing the potential need for regulatory intervention.

An alternative scenario in a low revenue market is *horizontal integration*, with the supply-side moving from MNO infrastructure-based competition to one with an independent infrastructure company and former MNOs competing as SPs. Although such a situation would, in theory, allow SPs to access a network on a non-discriminatory basis, it is likely that the level of regulatory intervention would have to increase, particularly in relation to price controls (on the infrastructure company) and potential tacit collusion between SPs and the infrastructure provider (to limit access to new SPs).

At the other extreme, were there to be a market with high demand, MNOs would still be under considerable pressure to provide an attractive return on investment to shareholders. In such a market, there could be a move towards *vertical integration*, with MNOs entering into joint ventures with large content providers on an *exclusive basis* to secure a higher share of value added. Under such a scenario, NRAs could be called upon to act if content providers seek access, but are refused because MNOs have already established exclusive arrangements with their competitors.

Even under a high revenue market scenario, there will still be a commercial imperative to minimise costs. The need and desire to share infrastructure is more likely amongst a market's weaker players. In such instances, existing competition law under Article 81 (3) would come into effect. There may likewise be actual mergers between MNOs, but again, such developments would be subject to scrutiny (*ex ante*) under competition rules.

Conclusions and Recommendations

Nature of Market

The mobile telecommunications market is experiencing a paradigm shift against a background of *uncertainty* in relation to the economic returns achievable in an *untested* post-2G market where businesses will be competing for personal and corporate users, who are knowledgeable about, and demanding of mobile telecommunications services, and require, and are capable of identifying, value for money.

Commercial Environment

With new entrants in most Member States, overall competition has been increased. Mandatory national roaming will also allow new entrants to compete in the current 2G voice market, with commentators expecting them to use voice as a loss leader to build market share, with a knock-on impact on all service prices.



As a result, the financial pressures on MNOs will create a commercial imperative to reduce costs and rapidly generate additional revenue by selling new value added services.

In addition to (the option of) developing their own value-added services, there will be a strong motivation for MNOs to enter into commercial agreements with third party SPs, where they are able to achieve an equitable balance between each party's risk and reward. In a value-added service environment, there is no commercial rationale for an MNO to merely sell 'minutes', since they retain all the risk (associated with having developed a network) and none of the reward.

Given the costs incurred by MNOs to compete in post-2G markets and increases in competition in traditional voice markets, without being able to benefit from a sufficiently (large) share of an SP's margin on value added services, MNOs are unlikely to see a return on investment, and will, therefore, be reluctant to grant access.

Regulation

Regulators are likely to be faced with access problems in relation to bottleneck network facilities and supply-side developments, which may see MNOs moving towards *vertical integration* in order to increase their share of value added in a given market/service value chain, and *horizontal integration* in order to reduce costs.

Given the uncertainty surrounding the commercial viability of 3G markets, they are likely to be highly sensitive to any (perceived) regulatory intervention. Although market players have clearly committed themselves to the market, any moves or decisions, which (appear to) threaten their ability to generate new value added revenue either themselves or through agreements with third parties could:

- cause MNOs to scale back investment
- precipitate/accelerate supply-side consolidation
- result in protracted legal disputes, during which time market development is likely to be held back as concerned parties await their outcome.

It would seem unlikely that NRAs will be able not to intervene, as the financial attractiveness of the market for SPs (offering value added services) is likely to lead to disputes with MNOs over commercial terms. However, if this were possible, a 'worst case' scenario could see MNOs not providing access to any third parties and putting in place 'gardens', both of which could limit consumer choice and development of a competitive market.

Irrespective of an NRA's preference for either intervention or non-intervention, they will inevitably be called upon to intervene in access cases where commercial negotiations have failed, and cases involving horizontal integration (primarily infrastructure sharing).

Within the context of the (proposed) Common Regulatory Framework, NRAs will have significant powers in relation to MNOs with SMP. *In our view*, it will be critical to this new value added market's successful development that:

- application of the rules be consistent across EU markets



- all parties 'buy into' an efficient and transparent dispute resolution process
- any intervention encourage involved parties to share risk and reward.

In order to increase the *certainty* and *consistency* in the application of the proposed Common Regulatory Framework, *we recommend that* the European Commission work with either the Communications Committee and/or Higher Level Regulation Group to produce regular guidance papers ('soft law') based on peer reviews of its application.

In our view, in rapidly moving mobile telecommunications markets, it will be critical to have a dispute resolution process within which all parties accept an NRA's decision as binding, rather than pursue additional litigation. This requires all parties to 'buy into' and commit to the process. Given this, *we recommend that* NRAs actively explore the use of self-regulation, whereby MNOs are mandated to develop (self-regulatory) codes in relation to access, which would include the handling of disputes, or co-regulation, whereby industry representative bodies are mandated to produce the same.

Risk and Reward in Value-added Markets

The application of the non-discrimination obligation to an MNO with SMP in relation to the provision of access to an SP could have significant negative consequences for market development. From a commercial perspective, it is in an MNO's interests to enter into joint venture-type agreements with SPs, whereby it is able to secure a share of the value added 'in exchange for' the risk incurred in developing the network. There is a wide range of possible SPs, with different potential access requirements. Non-discrimination, in contrast, assumes all third parties (SPs) are alike, which, in a value-added market, would not be the case. The potential threat of (application of) the non-discrimination obligation could therefore cause MNOs not to enter into innovative agreements with niche SP out of concerns that they will be required to offer the same terms and conditions to other – different – SP.

Whilst Article 13 of the A&ID requires NRAs to take account of MNO's investment costs and the need to safeguard competition in the long run, should a cost-based pricing obligation be imposed, calculation of a reasonable rate of return in an immature value added market will be far from simple.

In our view, in a market, which is based on added value and where, by definition, there is no standard 'bit' price, MNOs should be able to price according to the value of the service being provided over its network. Such an approach would establish the basis for true market pricing on an ongoing basis, which, in turn, should facilitate sustained competition in the long term. It would also overcome the potential negative impact of artificially 'fixed'/standard prices, which could result from regulatory intervention, and which would not reflect the reality of rapidly developing value added markets.

Even so, it is likely that NRAs will become involved in disputes in relation to commercial terms. There may be a value in exploring the possibility of developing a 'mediation tool', which uses a sliding scale methodology linked to the SP's 'service margin' over and above 'air time', whereby an MNO's revenue increases in proportion to the SP's value added margin. Although, inevitably, artificial, this could encourage the market's development by facilitating 'win-win' agreements and making MNOs with SMP less inclined to develop methods of avoiding regulation, which, in itself, would be counter-productive.



1. INTRODUCTION

1.1 Study Aims

The study's overall aim was to provide the European Commission with recommendations and guidelines for an approach to the regulatory treatment of access to **future mobile network infrastructures** and **network intelligence**

Within the context of this overall aim, the study's objectives were to:

- describe the 'drivers of change' likely to determine the market's development
- define the potential types of access required by companies (without networks) looking to enter the market
- describe current and planned (draft) access rules within the EU, and the nature and experiences of such regulation in liberalised non-EU markets
- generate market development scenarios, and assess their implications for regulators, particularly in relation to practices which could restrict competition
- develop recommendations for an EU regulatory approach, including dispute resolution.

The study takes as its core assumption that regulation's role is to facilitate the development of a competitive market for mobile telecommunications services to the benefit of personal and corporate end users rather than penalise or encourage any particular type of market player.

Although the report examines possible market and access scenarios, they are not prediction of how the market is likely to, or should, develop. Clearly, if the market develops in a competitive manner, there will be no need/basis for regulatory intervention.

1.2 Approach

The study was carried out between January and May 2001 and involved a comprehensive desk research programme, which was supplemented by in-depth interviews with 82 organisations.

Interviews focused on organisations' views of:

- the future mobile telecommunications market as it moved from its current circuit-switched (2G) voice-centric focus to the provision of packet-switched multimedia services using 2.5G (GPRS) and 3G (UMTS) technology
- the factors critical to the successful development of this market, in general, and the role, and potential impact, of the regulation of access (to mobile networks), in particular.



An overview of organisations interviewed is shown in Table 1, with a more detailed breakdown given in Appendix I.

Table 1 Interview Programme

<i>Organisation</i>	<i>Number</i>
National Regulatory Authority (NRA)/Government Ministry	20
Industry Body	8
Consumer Organisation	1
Mobile Network Operator (MNO)	23
Enhanced Service Provider (ESP)/Mobile Virtual Network Operator (MVNO)	6
Telecoms Service Provider	6
Internet Service Provider	4
Content Provider / Content Aggregator	2
Portal	4
Manufacturer	4
Other	4
Total	82

A summary of the opinions and attitudes of the key industry actors interviewed is shown in Appendix II.



2. ACCESS IN THE 2G ENVIRONMENT

2.1 Regulatory Situation

In the current 2G voice-centric mobile market, access to (mobile) networks has been on the basis of commercial negotiation, with disputes handled under the Interconnection Directive.

To date, disputes have tended to take a significant period of time to resolve, – much greater than the prescribed 6 months - , examples of which are:

- *Debitel - Viag Interkom (Germany)*. Viag, the latest market entrant, cited their low market share as grounds for refusing access to Debitel's request to become a Service Provider on its network. The NRA initiated an analysis of the market, which took more than a year to complete. Although the result showed that Viag's market share was high enough to be obliged to contract with Service Providers, the German NRA concluded that it is not required to impose a solution to the dispute. Current indications are that the dispute will be settled in the civil court, with legal proceedings currently in progress
- *Cellular 3 (Meridian) - Eircell (Ireland)*. Cellular 3's attempt to sustain an MVNO operation ("Imagine!") on the Irish market relied on their agreement to use Eircell's network. Eircell decided to terminate their agreement, which led to a dispute centring on whether Eircell was *dominant* in the market (under competition law). The Irish High Court has ruled that Eircell was not dominant, and so, *despite Eircell being designated as having SMP by the NRA*, Cellular 3 has been unable to compel Eircell to provide access
- *INMS - Vodafone/Cellnet (UK)*. INMS, as a licensed operator, applied to offer carrier selection services via Vodafone's network in February 1998. Vodafone refused to set a price, and INMS raised the issue with Oftel as a dispute under the Interconnection Directive. The dispute is still ongoing in 2001. As of December 1999 and July 2000, Oftel determined that INMS could gain access to the networks of Vodafone and Cellnet (who also subsequently refused access) at an interconnection price based on "retail minus". However, the method of calculating this made the access price directly linked to Vodafone's retail prices, whereas INMS argued that this was a distortion of competition, and that competing operators are within their legal rights to obtain access pricing related solely to the service provided to them. This would give competing operators the freedom to be able to offer their own products based on an interconnect product from MNOs. The company has complaints running with both DG Competition, and DG Information Society regarding the situation
- *Telia Finland (Finland)*. Telia's complaint arose from its request for *national roaming* on other operators' networks to supply nationwide coverage following limited build-out. When negotiations broke down, the NRA refused to intervene as national roaming was intended to be a matter for commercial negotiation. The case was subsequently referred to the European Commission, and then back to the Finnish Ministry of Transport & Communications, which upheld the initial decision.



2.2 Service Provider Access Trends

Despite disputes, Service Providers (SPs) are active on mobile networks (see Appendix III). There also appears to be an increasing willingness on behalf of Mobile Network Operators (MNO) to provide third parties with access to their networks on the basis of commercially negotiated 'win-win' agreements.

Whilst attitudes and approaches are clearly market and MNO-specific, there seems to be a recognition that SPs can add value by:

- profitably increasing network utilisation
- filling excess capacity
- growing market share in existing market segments
- facilitating entry into new market segments.

The benefits of SPs appear particularly attractive in mature markets with well-established competitors. In this context, agreements have tended to be struck with SPs, which have a strong brand and large (loyal) customer bases, including:

- major retail chains, which have been looking to increase the number of 'touch points' with their customers. MNOs have benefited from increased traffic and, for those with a corporate focus, an efficient and effective means of entering the consumer market (and taking business from competitors)
- non-competing fixed line telecoms providers, looking to offer a total package to their customers. In such instances consumer-focused MNOs are dealing with operators with a large commercial customer base.

The increasing interest in wholesale agreements also reflects, in some cases, a change in MNO attitude away from seeing itself as a network operator, which has to have sole use of its assets (infrastructure), to a business, whose focus is to leverage its assets to maximise revenue and profits. This is particularly the case as the industry moves into an era where data will become the primary driver for increasing revenue, since data is applications driven, and partners with applications knowledge (systems integrators) will be essential.

The market has also seen the introduction of a new concept - the Mobile Virtual Network Operator (MVNO). However, this has been confused by a lack of a common definition and understanding of what it is to be an MVNO. There appears to be consensus that an MVNO does own some infrastructure and offers mobile subscriptions and services, but that it does not have spectrum. It is the nature and extent of the owned infrastructure, which is 'required' for an SP to be considered an MVNO that differs. A common minimum requirement appears to be ownership of the mobile switch and billing functionality. Given this, 'full' MVNO deals seem limited today to those of Sense with Telia in Sweden and Sonofon in Denmark, and Tele 2 with Sonofon in Denmark.

From an access perspective, it is more sensible to talk about an increase in 'MVNO-type' agreements (see Appendix III), with an emphasis on ESP-type arrangements, such as Virgin Direct's joint venture with One2One in the UK. Although such ventures are often associated with MVNOs, this is, in reality, not the case.



3. TRANSITION TO A MULTIMEDIA MARKET

3.1 Overview

The move from supplying network-based voice-centric services using circuit-switched (2G) technology to IP-based value-added multimedia services using packet switching (2.5 and 3G) technologies represents a 'revolution' for Mobile Network Operators (MNOs). This change from being principally sellers of a (price-driven) commodity - air time - to providers of value-added multimedia services, will cause MNOs to act and compete in a fundamentally different fashion. It is taking place - and is likely to continue to take place - in a business environment characterised by risk and uncertainty, particularly in relation to:

- changes in the supply-side
- application of the proposed new Common Regulatory Framework
- the global economy, generally, and their (MNOs') own financial situation, specifically
- the economic viability of (3G) multimedia markets.

The reality of the situation was illustrated by one of the EU's largest operators, which, in Quarter 2 of 2001, warned its shareholders that it was unable to provide any assurances that it would make an economic return on its investments in third generation licences and networks, given that:

- the size of the market for 3G (multimedia) services is unknown
- competition is expected to be intense
- the technology is (currently) unproven.

This element of uncertainty in relation to the risk and rewards of investing in packet-switched broadband networks has also been echoed by a number of market observers.

3.2 Market Drivers

3.2.1 Overview

The following key drivers of change and their interaction will determine the business environment within which the new multimedia market has to develop:

- costs incurred by MNOs to enter the post-2G market
- the global and regional economic climate and its impact on the demand for telecommunications services during the critical investment/build-out period



- the nature and extent of take up of new value added services from both businesses and consumers
- regulatory framework within which they are required to operate
- effectiveness of the facilitating technology.

Although all drivers are important, the commercial imperative for operators to generate a return on investment will be key, and is likely to influence strongly both attitudes and strategies.

3.2.2 Economic

3.2.2.1 Operator Investment Costs

In order to compete in this significantly different business environment, MNOs are likely to (have to) change their corporate cultures and behaviour, with decisions increasingly driven by commercial rather than technological considerations.

A key driver in this respect will be the costs associated with the move to 3G networks, in terms of:

- the acquisition of 3G licences (in some Member States), which has led to significant increases in levels of debt (see Table 2)
- future expenditure on network build out and marketing.

Table 2 Selected Telecoms Operator Debts, End of 2000

<i>Operator</i>	<i>Debt (Euro billion)</i>
Deutsche Telekom AG	62
France Telecom	61
British Telecommunications plc	45
KPN Telecom	22
Mobilcom	12
Vodafone	11
Sonera Corporation	6

Sources: FT.com; Actualidad Económica; EuroStrategy Consultants, 2001

Although the levels of expenditure vary by Member State, competition is generally greater than in the 2G environment, and costs per capita are high even in smaller markets (see Table 3).



Table 3 Estimated Licence Fee and Infrastructure Costs per capita

<i>Member State</i>	<i>Euro</i>
Germany	985
UK	1,074
Italy	455
Spain	521
France	337
Netherlands	491
Finland	778

Source: EuroStrategy Consultants, 2001

Note: Estimated build out costs are Euro 5 billion in all Member States except Finland and The Netherlands (Euro 1 billion)

MNO strategies and philosophies will inevitably be strongly influenced by the need to recover these costs (see Table 4).

Table 4 Estimated Impact of 3G Investment Costs on Annual Profits of 'Average' German MNO

	<i>Euro (mn)</i>
Licence Cost (a)	8,467
Annual Licence Depreciation over 20 years (b)	423
Estimated Network Cost (c)	5,000
Annual Network Depreciation over 10 years (d)	521
Annual Financing Charges at 7% (e)	943
Annual Negative Impact on P&L Account (b + d + e)	1,866

Under the same assumptions, the estimated impact on annual profits at an industry level could range from almost Euro 6 billion in Germany to some Euro 430 million in Finland (see Figure 1).



Figure 1 Estimated Annual Negative Impact on Industry Profits of 3G Investment Costs

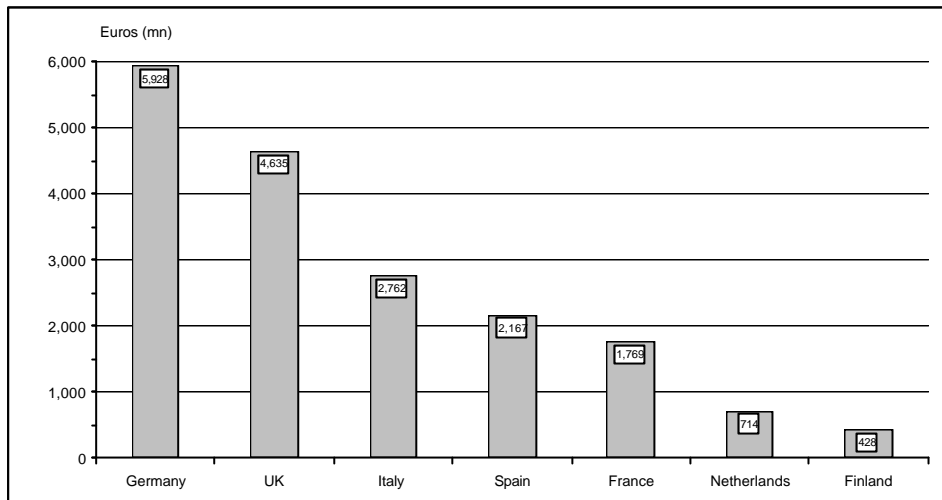

Source: EuroStrategy Consultants, 2001

Faced by a 'new' market where risks are high and rewards far from clear, all players will be under pressure to:

- reduce costs, pushing them towards horizontal integration
- rapidly generate additional new value added revenue (for existing players) and voice and non-voice income (for new entrants, which will have extra costs associated with building a brand and customer base), encouraging vertical integration.

The recent interest and increase in deals with SPs (see **2.2**) is perhaps indicative of the direction in which MNOs are likely (may have) to move.

3.2.2.2 Macro-economic Performance

The performance of national economies does not, in general, drive a market's development, but rather regulates the speed of its growth.

The effects of the US economic slowdown, which started in the second half of 2000 and rapidly spread to Asia, and more recently, the European Union in the first half of 2001, are already being felt in the telecommunications market. National operators and equipment suppliers are issuing profits warnings, reducing staff, and attempting to improve debt to equity ratios. The depth and duration of the current slowdown is far from clear.

This uncertainty is likely to threaten further MNOs' ability to achieve a return on investment (within commercially acceptable timescales).



3.2.3 Social

Although the speed of take up of services will be 'regulated' by economic growth, the actual 'base' levels of demand for post-2G services is still far from certain, particularly in relation to:

- the nature of services, which consumers will purchase and the size of premium, if any, they are prepared to pay for (what the supply-side considers to be) 'value added' services
- the willingness of users in many Member States to accept a reduction in MNO subsidisation of mobile devices.

For MNOs seeking to 'control' their subscribers in the multimedia environment, the extent to which consumers are content with 'walled gardens' – however large and attractive they may be – will determine the extent to which they are able to increase their share of value added.

3.2.4 Regulation

3.2.4.1 Licensing - Intensity of Competition

As at the end of May 2001, the overall number of MNOs in the EU had risen from 52 to 66 (see Table 5), with:

- the recent issue of 3G licences having resulted in new market entrants in most Member States
- Denmark, Greece, Ireland and Luxembourg still to award UMTS licences
- licences still available following initial selection procedures in Belgium and France.

At the same time, spectrum for 2G services is still being made available in Member States, with:

- Denmark having recently made more spectrum available
- Portugal, Spain and Sweden planing to award further licences.

With national 3G-2G roaming mandated for new entrants in ten Member States, competition will intensify for:

- current 2G voice customers, with new entrants likely to use voice as a loss leader to build market share
- future multimedia business.



Table 5 EU Telecoms Operators licensed for Mobile Networks, 1999/2001

<i>Member State</i>	<i>1999</i>	<i>May 2001</i>
Austria	4	6
Belgium	3	3
Denmark	4	4
Finland	4	4
France	3	3
Germany	4	6
Greece	3	6
Ireland	3	4
Italy	4	6
Luxembourg	2	2
Netherlands	5	5
Portugal	3	4
Spain	3	4
Sweden	3	6
UK	4	5
Total	52	66

Source: EuroStrategy Consultants, 2001

3.2.4.2 Regulatory Powers

The proposed new Common Regulatory Framework provides NRAs with power to impose significant obligations on MNOs with SMP. However, the Framework's move away from a (telecommunications) sector-specific approach towards one more closely aligned to Community competition law will result in National Regulatory Authorities (NRAs) being faced with a number of key issues ('problems'):

- how to interpret the competition law definition of Significant Market Power (SMP), which is broader and more 'complex' than the current 'quantitative' 25% market share measure
- how to define the relevant market when assessing SMP in a multimedia environment where, arguably, only (mobile) voice telephony is a clear market
- which of the powerful 'toolkit' obligations (transparency, non-discrimination, unbundled access, cost-orientation) should NRAs decide to apply where SMP is established in a relevant market, and for how long.

Although the proposed Framework's flexibility will allow NRAs to address new market problems, it may lead to different interpretation and, in consequence, application in Member States, and a lack of *certainty*, which could influence (both positively and negatively) market players' investment decisions.



3.2.5 Technology

At the highest level, technology is a market facilitator, rather than driver. In this respect, the availability of specifications, for example in relation to IPv6, equipment and devices are crucial. However, its importance will lie in the challenge it presents to MNOs' traditional business models.

Full 3G systems will employ a new air interface, and have fully packet-switched core networks. Initial 3G rollouts will feature Asynchronous Transfer Mode (ATM) in the Access and core networks. Before then, 2.5G (GPRS) technology will involve an overlay of packet switching capabilities for data onto GSM. 3G rollout for existing 2G operators will involve adding a new Radio-Access Network (RAN) and later upgrading to an ATM core from the current circuit switched core. Clearly 3G rollout for a new operator will include the ATM core immediately. The full development of packet switched core networks and IP-based services will enable multiple access networks to be used, including DSL, wireless LAN as well as 3G mobile.

Central to UMTS has been the development of a new Radio-Access Network (RAN). This will provide:

- greater spectrum efficiency
- Quality of Service (QoS) management
- soft handover between cells
- the facility to offer a greater variety of applications via variable bit rates.

The basic functionality of a (2G) mobile network will remain the same, with (2G) circuit switching technology equipment being replaced by packet switching technology equipment, for example:

- 2G Base Transceiver Stations (BTSs) and Base Station Controllers (BSCs) will be replaced by Node Bs and Radio Network Controllers (RNC)
- the 2G services and home environment provided by network intelligence will be replaced by an analogous systems
- gateways will be introduced, with:
 - Gateway GPRS Support Nodes (GGSN) to provide access to services over packet networks (Internet)
 - Media Gateways (MGW) to allow interfacing to the PSTN - the role currently undertaken by the Gateway Mobile Switching Centre (GMSC).

These differences are illustrated in Figure 2, which shows a simplified network architecture.



Figure 2 2G to 3G Network Schematic

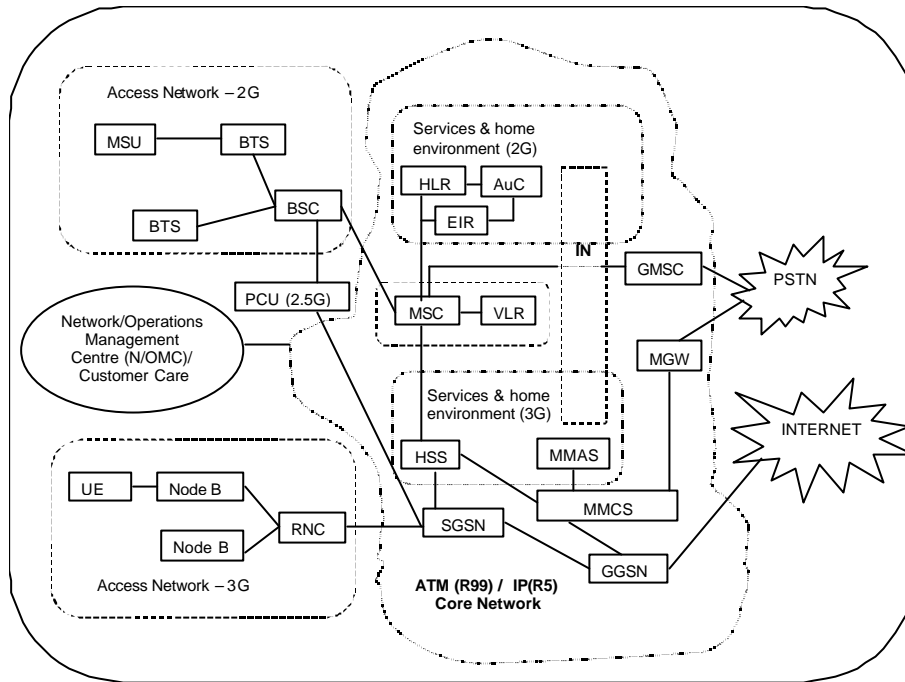

Key

Function	Voice Infrastructure - 2G		Data infrastructure - 2.5G/3G	
The wireless device	MSU	Mobile Subscriber Unit	UE	User Equipment
Radio at the centre of a cell	BTS	Base Transceiver Station	n/a	Node B
Signalling & management of cell resources	BSC	Base Station Controller	RNC	Radio Network Controller
Routing of calls	MSC	Mobile Switching Centre	MSC	Mobile Switching Centre
Provides network access and mobility management - the future of the MSC			SGSN	Serving Gateway GPRS Support Node
Stores location of devices temporarily within an MSC's coverage	VLR	Visitor Location Register		
Contains location of all units registered to the (home) MSC	HLR	Home Location Register	HSS	Home Subscriber Server - contains user ID, security info, location data, user profile
Provides user with virtual home environment as well as 3 rd party services			MMAS	Multimedia Application Server
Enables a device to use the network	AuC	Authentication Centre		within HSS
Lists unique numbers to identify devices - enables billing & prevents fraud	EIR	Equipment Identity Register		within HSS
Connects mobile network to other voice networks (PSTN, ...)	GMSC	Gateway Mobile Switching Centre	GMSC	within HSS
Adapts base station for packet data		n/a	PCU	Packet Control Unit (2.5G)
Supports & controls VOIP & multimedia		n/a	MMCS	Multimedia Call Server
Provides access to services area over IP data networks (eg the Internet) - hides complexity of mobile network from the Internet		n/a	GGSN	Gateway GPRS Support Node
Responsible for interworking with the PSTN		n/a	MGW	Media Gateway



At the other “end” of the network, third parties have the facility to interconnect, and to install equipment such as WAP gateways. At this point in 2G, network operators are still able to control the cost of calls made to (independent) WAP gateways.

Network access is currently complicated by the number of conversions between different protocols in the system and preferred systems of addressing. Full 3G networks will support IPv6, which is able to guarantee the timeliness of channels for rich multimedia applications, such as videotelephony. Full standardisation of the environment will be made in the forthcoming Release 5 of the 3GPP’s UMTS specifications at the end of 2001/beginning of 2002.

An overview of current standardisation activities is shown in Appendix IV.

3.3 Potential Markets and Services

3.3.1 Overview

The *technical* transition, from *circuit-switched* to *packet-driven* data in high-speed IP-based (2.5G and 3G) networks, will enable, and act as a catalyst for, *services* transition, with a shift away from a primarily price-based “commodity” voice service to a value-based service proposition, which will offer consumers a range of enhanced bespoke voice and data services. Voice *is*, however, expected to remain the core revenue-generating service until at least 2007.

Mobile *multimedia services* arise from the convergence of computing, communications and established media, and delivered via mobile communications networks. Such services will be a total integration of voice, data and video images, in two-way (interactive) communication mode. There is also an emerging ‘low’ multimedia, which is utilised on i-mode (the playing of games, downloading music, ...), and requires relatively small file sizes of less than 100K.

This will result in three main changes in the nature and provision of services:

- the IP “always-on” environment will offer any time, any place connectivity, with end users able to specify their requirements
- the single service voice world will proliferate into various services and service bundles, multiple business models and revenue sharing, which is likely to result in partnership arrangements between MNOs and other value chain players to develop *new* “valued added” services
- customer billing will shift from cost per unit of time to payment per amount of data downloaded or according to the value-added provided to the end user.

An overview of potential services and customers (markets) is shown in Table 6. In principle, almost any combination of service and customer is possible, although customised infotainment and m-advertising are unlikely to be targeted at the business market, and mobile intranet/extranet access focusing on the business market.



Table 6 Potential post-2G Markets

Services	Customers	Business				Consumer				
		MNC	N'tnal	SME	Micro	8-12	13-21	22-35	26-54	55+
2G Voice										
3G Rich Voice										
Mobile Internet Access										
Mobile Intranet and Extranet Access										
Rich Multimedia Messaging Services (MMS)										
Customised Infotainment (Mobile Portal)										
Location Based Services										
M-commerce										
M-banking										
M-advertising										

Post-2G services are expected to be *user-driven*, offering customisation that is specific to a user's "personality", location and time.

3.3.2 Voice

In the IP-based, 3G environment, *voice telephony* becomes a more essential component in most mobile data services and will be more affordable to users. Enhanced as "Rich Voice", real-time and two-way, advanced voice capabilities will be provided, such as Voice over IP (VoIP), voice-activated net access and Web-initiated voice calls. Traditional features will be retained, but with higher data rates, mobile voice services will include videophone and multimedia communications.

3.3.3 Data

Multimedia will be the key difference between 2.5G and 3G product offerings. While GPRS will provide streaming video and audio (high quality MPEG-4), 3G will be able to supply *this*, plus:

- *Mobile Internet/Extranet*, which will target both business (fixed Internet subscribers, which require mobility) and consumer users. Beginning as a combination of basic Internet and e-mail, full multimedia and web browsing will become available via 3G technology
- *Multimedia Messaging Service (MMS)*, which will offer a more sophisticated form of SMS (2G) and basic messaging services of GPRS (such as e-mail) offering real-time, multimedia messaging with always-on capabilities, and allowing provision of instant messaging, targeted at closed user groups that can be SP- or user-defined. The service is expected to develop from pictures (small GIF images) through enhanced messaging (small animation integrated with text) to true multimedia (video and audio integrated with text)
- *Customised Infotainment*, which will offer "device-independent access to personalised content anywhere, any time via structured-access mechanisms based on mobile



portals.” Services could include news/alerts, “time fillers”, such as horoscopes, and entertainment, covering gaming and gambling (mobile betting), (short clip) mobile video and mobile audio

- *Location-based Services (LBS)*, which will enable users or machines to find other people, devices, resources, services or machines, and also allows users to determine their own location (via a mobile portal). This is already available in some countries, for example, The Netherlands where the network provides users the postal code of the region in which they are located. Key applications are likely to include:
 - local commercial services information (hotels, restaurants, ...) would be available in “push” (user specifies requirement at a given moment, with terminal able to provide information specific to location) and “pull” (a previous user requirement triggers a location-specific response) modes
 - mapping and routing services, providing navigational information to the user
 - entertainment
- micro-payment (m-commerce, m-banking) services, such as equity trade or customer access to account information and retail payment (vending machines, restaurants, ...).

3.3.4 *Service Value/Pricing*

The move to a value added market will change significantly the way in which services are priced. In effect, every bit will have a different value, with a range of varying models likely to emerge (see Table 7).

Table 7 Potential Service Pricing Models

<i>Service/Pricing Method</i>	<i>Metered</i>				<i>Unmetered</i>
	<i>Time</i>	<i>Data Volume</i>	<i>Value</i>	<i>Location</i>	<i>Flat Rate</i>
Mobile Internet Access	✓	✓	✓	✓	✓
Voice	✓		✓	✓	✓
E-Mail		✓	✓		✓
Instant Messaging		✓	✓		✓
Content			✓	✓	✓

Sources: Durlacher Research Ltd; EQVITEC Partners Oy, 2001

In addition, different pricing/payment units are likely to be used (see Table 8).



Table 8 Potential Service Pricing/Payment Units

<i>Application/Service</i>	<i>Pricing Unit</i>
Voice, videoconferencing	Minute
Wireless LAN access	Megabyte (Mb)
SMS	Message
Video-on-demand	View
Ring tones, music downloads, purchase commission	Transaction
WAP stock quotes	Ticker symbol
Click-through advertising	Click
Location based advertising	Response
Software rental	Seat
Fax	Page
Direction-finding services	Mile
Games	Bullet
Sport update video clip	Goal

Sources: Durlacher Research Ltd.; Geneva Technologies, 2001

3.4 Potential Service Providers

3.4.1 Overview

A Service Provider (SP) is a business without a network, which requires access to an MNO's infrastructure to deliver its offering to the (mobile) market.

In the current 2G world, all SPs in practice offer a variation on MNOs' 'basic' voice telephony service, and fall into three broad categories:

- air time resellers
- Enhanced Service Providers (ESP)
- Mobile Virtual Network Operators (MVNO).

SPs differ primarily in the amount of infrastructure they own and, therefore, the 'depth' of mobile network access required. All have their own customer bases and, therefore, *at a minimum*, require access to billing information in order to invoice, although this would not necessarily apply to a full MVNO, which, in theory, has all the elements of an MNO other than the radio access network (radio antennae and the capability to transmit and receive signals over the airwaves).

However, in the post-2G value added environment, the nature of potential SPs could change, and fall into three main categories:

- telecoms services providers



- content owners
- value added mobile service providers.

As shown in Figure 3, these are likely to differ from existing 2G SPs, with, for example, content owners and mobile service providers using:

- elements of the network to provide value added services
- MNO networks as an additional distribution channel to existing customer bases.

It seems unlikely that air time resellers will be able to sustain their business in a post-2G/3G environment, which will be increasingly characterised by value added service, with greater competition, particularly for voice traffic, between a larger number of operators.

Figure 3 Generic Potential Service Providers

Service Provider	Service Offering			Own Customer Base
	Network Facility	Own Service	Telecoms	
Telecom Services Provider		X	X	Yes
Content Owner	X	X		Yes
Mobile Service Provider	X			Not necessarily

3.4.2 Telecoms Services Providers

Telecoms Services Providers could include:

- (existing) *fixed operators*, which are looking to offer integrated fixed/mobile services to their existing customer bases
- *mobile telecoms operators*, which would, in effect, be competing directly with their 'host' MNOs, as so-called MVNOs
- *content owners*, such as large retail chains, which would seek to leverage their brand and customer bases and operate as Enhanced Service Providers (ESPs).

Such SPs would wish to provide their customers with mobile devices.

3.4.3 Content Owners

Broadband networks could facilitate SPs, which own valuable content, and which wish to sell/provide it via the (3G) mobile sales channel. These could include, for example:

- retail outlets, in terms of m-commerce
- banks and other financial institutions, in terms of m-banking



- mobile (Internet) service providers, which would like to be accessed via the mobile as well as fixed channel.

Such SPs would provide their services via *MNOs* or *Telecoms Service Providers*. If a retail outlet were, for example, to provide its customers with mobile devices, it would, in effect, become a *Telecoms Service Provider*.

3.4.4 Value Added Mobile Service Providers

A potentially new type of SP could develop around MNOs' network facilities, particularly location data. Such SPs are likely to want to provide their service to an, or all, MNOs' customers, and would, therefore, be an SP to an MNO.

Such SPs could also include existing fixed Internet sites, which would be accessed via MNOs' own mobile portals.

3.5 Possible Value Chains

In the 2G world, the MNO dominates a relatively simple value chain, and generally enjoys close to 100% of the value of, in practice, selling air time. The convergence of mobile and Internet technology in the 3G world changes this paradigm, with the *non-voice* element of the multimedia value chain dominated by *enablers* – in particular, content providers and content aggregators, as illustrated in Figure 4.

Figure 4 Multimedia Value Chain

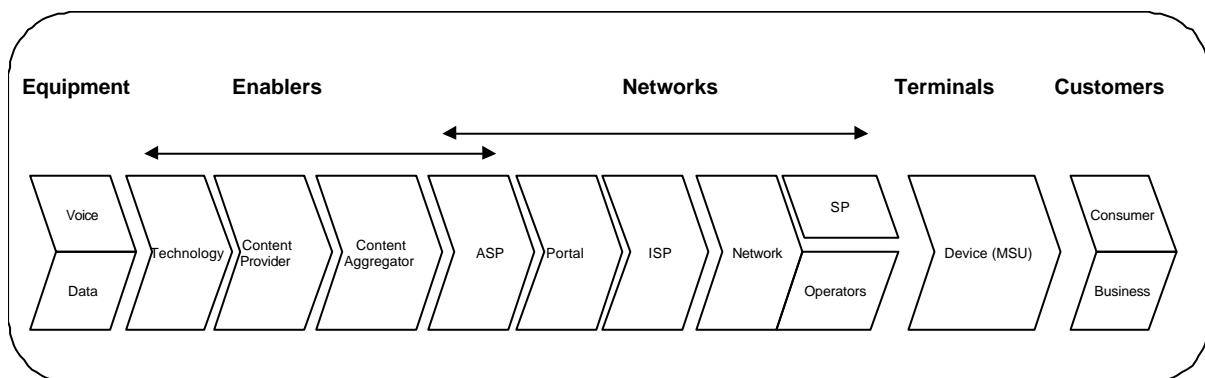

Sources: Dundee Securities; EuroStrategy Consultants, 2001

As a consequence of this change in the value chain, as a service's value added increases, an MNO's share decreases – if it assumes a transport facility role only (see Figure 5). However, in order to justify investment, *overall* revenue has to be higher (than that without investment).



Figure 5 Value Chain Economics

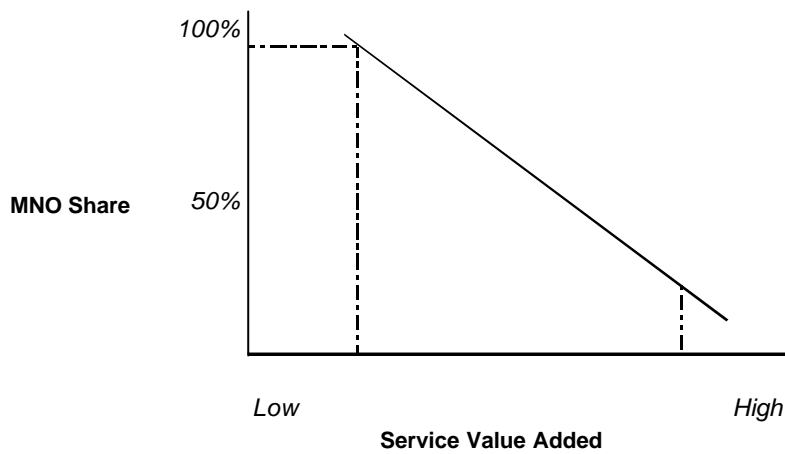

Source: EuroStrategy Consultants, 2001

In this respect, vertical integration to capture more value added becomes a commercially sensible strategy. This, combined with the increasing competitive pressure to offer a value proposition to its customers is expected to lead to MNOs entering into agreements with a range of content providers (see Table 9).

Table 9 (Mobile) Multimedia Players

Market/Sector	New (3G) Players	Examples
Financial institution	Bank, credit card company, billing company	Barclays, VISA
Vendor	Platform provider, infrastructure provider	Nokia, Ericsson
Wireless Application Service Provision	Wireless Application Service Provider (WASP), Wireless Application Infrastructure Provider (WAIP)	Wapit (SMS) Aether Systems
Content delivery (provision)	Wireless Internet Service Provider (WISP) Software development company Media company, entertainment company Content/application aggregator/packager, Mobile Portal/WISP	AOL Europe! Microsoft, Oracle CNN, Virgin Group Yahoo! Europe Iobox

Sources: "Understanding the 3G Value Chain", Questus April 2000; Yankee Group, April 2000; EuroStrategy Consultants, 2001

MNOs are likely to be faced with two strategic 'value' options:

- positioning themselves as a 'simple' delivery channel ('bit pipe'). At least one new 3G entrant is planning to adopt such a strategy
- moving up the value chain to capture more value by:
 - adopting the content aggregator/mobile portal role through acquisition, joint venture or setting up their own operation, for example, Vodafone's Vizzavi, and/or



- acting as a 'Wireless Application Service Provider' (WASP).

Some may also move into new markets that are central to the value chain by means of joint ventures and acquisitions. For example, some operators are developing payment systems transactions (Sonera's Sonera Mobile Pay and Telefónica Móviles's MovilPago), and are considering seeking banking licences, whilst others have entered into formal JVs with banks (T-online and Commerzbank).

Figure 6 The Multimedia Value Chain – MNO Strategic Options

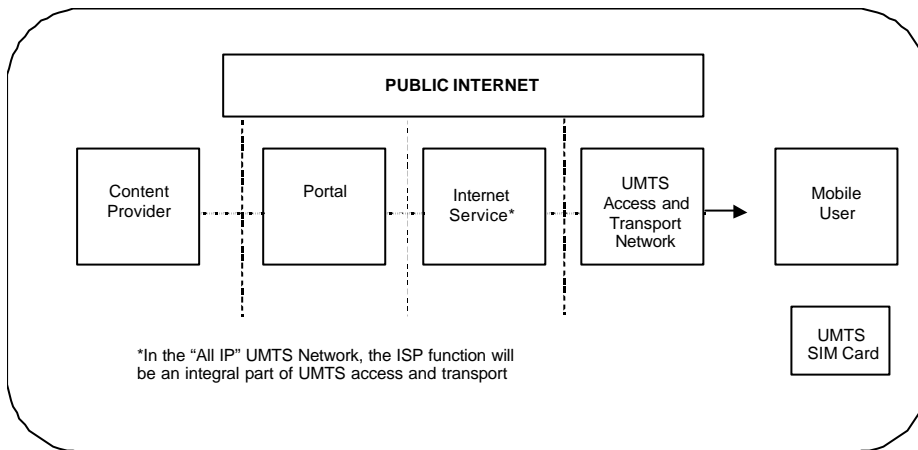

Bit Pipe

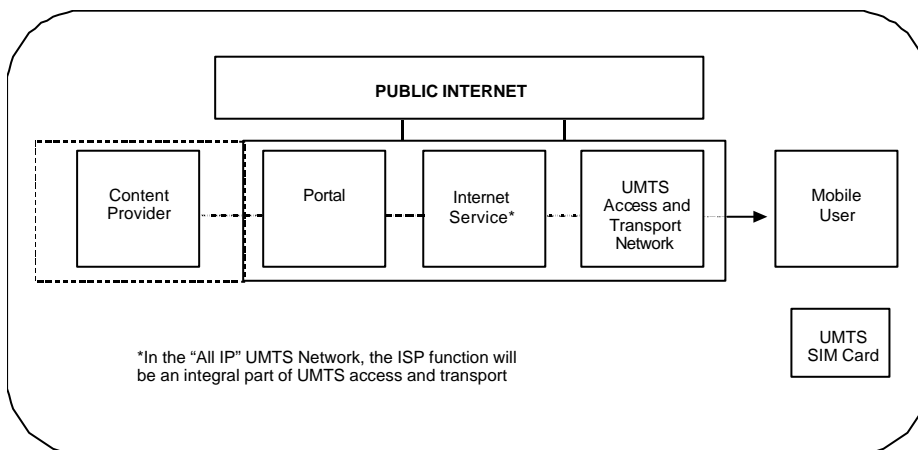

Aggregator/Mobile Portal

Source: UMTS Forum

The latter approach would allow an MNO to:

- exploit its unique billing/customer care systems (BACC)/relationships (CRM), brand, spectrum, licence and access to customer data



- tap into new sources of revenue (see Table 10).

Table 10 MNO Revenue Opportunities

<i>Traditional Revenue Sources</i>	<i>New Revenue Sources</i>
Service Installation Fee (activation)	Advertising/Sponsoring Revenues
(Monthly) Subscription Fee	Sales Revenues/Service Fees
Usage Fee (Air time)	Transaction Fee or Commission

Sources: "Understanding the 3G Value Chain", Questus, April 2000

Under both strategies, content providers remain independent, with the 3G MNO merely an additional delivery channel.



4. ACCESS SCENARIOS

4.1 Overview

The following sections examine potential access issues from three perspectives:

- the core network facilities likely to be required by SPs
- specific types of potential SPs
- overall market (supply-side) developments, which could challenge the regulatory 'status quo' established by the (proposed) Common Regulatory Framework.

These scenarios are not predictions of how the market is likely to, or should, develop.

4.2 Network Facilities

Although the types of access required by SPs will vary, there are a number of potential structural 'bottlenecks' in that *they are unique* to a network, and cannot be replicated (by a third party):

- information on subscribers, which, in a post-2G network will reside in the *Mobility Management System* (MMS):
 - device/subscriber location data
 - security (authentication)
 - information on the nature of the receiving device (to allow content to be formatted appropriately)
 - micro-billing facilities/billing information
- an MNO's own mobile portal
- Application Program Interfaces (APIs).

There appears to be general agreement that access is not a technical (engineering) problem, with it being feasible to provide access to third party SPs anywhere on a network. There are clearly physical hardware capacity issues in relation to, for example, gateways, but this is not a technical problem, per se. The current interest in infrastructure sharing and the existence of independent infrastructure providers, such as Crown Castle, would appear to indicate that any technical access problem can be overcome.

The importance of access to such 'bottlenecks' is clearly linked to the type of potential SP, and this is discussed in detail in the following section.



4.3 Service Provider

4.3.1 Overview

The types of access required will be a function of the type of SPs likely to be active in the future mobile multimedia market, with requirements specific to individual businesses. At the highest level:

- *mobile telecoms services* providers looking, in practice, to compete directly with MNOs will require access to the complete network, although MVNOs, for example, are likely to own more infrastructure
- *content and value added (mobile)* service providers, which will, in general, be using a network as an additional sales channel, are more likely to focus on MNOs' network intelligence elements (see Table 11).

Table 11 Potential SP Key Access Requirements

'Generic' Infrastructure Service Provider	Core Network Entry Points			Network Intelligence		SGSN	Radio Access Network	Mobile Portal	MNO Subscribers
	Internet		PSTN	MM	ASP				
	GGSN	MGW	GMSC						
Mobile Telecoms Services	X	X	X	(X)	(X)	X	X		
Content				X	(X)			X	
Value Added Mobile Service				X	(X)			X	X

Key

GGSN	Gateway GPRS Support Node. Provides access to services area over IP data networks (eg the Internet) – hides complexity of mobile network from the Internet
MGW	Media Gateway. Responsible for interworking with the PSTN
GMSC	Gateway Mobile Switching Centre. Connects mobile network to other voice networks (PSTN, ...)
MM	Mobility Management (System). Contains user ID, security info, location data, user profile. Enables a device to use the network (authentication). Lists unique numbers to identify devices – enables billing & prevents fraud (equipment identity)
ASP	(Application) Service Platforms including, for example, SMS, IP Multimedia, Location Services, ...
SGSN	Serving Gateway GPRS Support Node. Provides network access and mobility management

4.3.2 Telecoms Services Providers

4.3.2.1 Definition and Service Offering

Telecoms Services Providers (TSP) could include:

- (existing) *fixed operators*, which are looking to offer integrated fixed/mobile services to their existing customer bases
- *mobile telecoms operators*, which would, in effect, be competing directly with their 'host' MNOs, as so-called MVNOs



- *content owners*, such as large retail chains, which would seek to leverage their brand and customer bases and operate as Enhanced Service Providers (ESPs).

Such SPs would provide their customers with mobile devices.

In principle, TSP could offer a complete range of voice, data and multimedia services and would, in effect, compete directly with the ‘host’ network in some or all service areas, although they are more likely to focus on a particular market segment or series of niches. All, however, are likely to offer a ‘basic’ voice service.

4.3.2.2 Likely Access Requirements

Access could vary from:

- ‘complete’ infrastructure and network intelligence for an Enhanced Service Provider (ESP), such as a large retail organisation, which, in effect, would ‘rebrand’ (and enhance) its ‘host’ MNO’s market offering, *through*
- a combination of key databases, particularly in relation to the state of the network for Service Providers, which wish to own some infrastructure, *to*
- ‘infrastructure only’ for companies adopting a full Mobile Virtual Network Operator (MVNO) business model. A full MVNO, in theory, has all the elements of an MNO with the exception of the radio access network (radio antennae and the capability to transmit and receive signals over the airwaves).

In all cases, however, access to billing information (calling data records) would be required.

Table 12 Potential Telecoms Services Provider Access Requirements

Core Network Entry Points			Network Intelligence		SGSN	Radio Access Network	Mobile Portal	MNO Subscribers
Internet		PSTN	MM	ASP				
GGSN	MGW	GMSC						
X	X	X	(X)	(X)	X	X		

4.3.2.3 Potential Access Problems

Disputes are likely to focus on failures to agree commercial terms, with MNOs seeking to secure a suitable return (reward) on their upfront investment costs (risk). There will be no incentive for MNOs to conclude agreements, which do not allow them a share of an SP’s value added. Since TSPs would be competing directly with their ‘host’ MNOs, there would be no commercial logic for an MNO to conclude an agreement, which, in practice, could reduce its own earnings potential.

MNOs are also likely to be concerned about striking deals, the terms of which (could) then become the basis for subsequent negotiations under the non-discrimination obligation, should they be designated as having SMP (in that particular market), even though the imposition of this obligation would not be automatic. In most cases, the wholesale price is likely to be the underlying cause for failing to reach agreement on access. However, the



stated reasons will invariably be technical of nature to avoid falling foul of competition law in relation to non-discrimination pricing, although some MNOs may also make use of commercial arguments, highlighting imbalances between risk and reward.

4.3.3 Content Owners

4.3.3.1 Definition and Service Offering

Broadband networks could facilitate SPs, which own valuable content, and which wish to sell/provide it via the (3G) mobile sales channel to their existing customer bases. These could include, for example:

- retail outlets, in terms of m-commerce and m-advertising
- banks and other financial institutions, in terms of m-banking
- mobile (Internet) service providers, which would like to be accessed via the mobile as well as fixed channel.

Such SPs would provide their services via *MNOs* or *Telecoms Service Providers*. If a retail outlet were, for example, to provide its customers with mobile devices, it would, in effect, become a *Telecoms Service Provider*.

4.3.3.2 Likely Access Requirements

Required access is likely to take the form of:

- location data for m-advertising services
- authentication (security) and billing information for m-commerce and m-banking services.

Although it is not strictly an access issue, it will be commercially important for:

- *either* the content owner's service to be easily found on a 'host' MNO's mobile portal
- *and/or* customers to be able to access the content owner's own mobile portal from the 'host' MNO's mobile portal.

This latter type of 'non-access' access will be particularly important for Mobile (Internet) service providers, including competing mobile portals.

Table 13 Potential Content Owner Access Requirements

Core Network Entry Points			Network Intelligence		SGSN	Radio Access Network	Mobile Portal	MNO Subscribers
Internet		PSTN	MM	ASP				
GGSN	MGW	GMSC						
			X	(X)			X	



4.3.3.3 Potential Access Problems

For non-competing content owners, it does not seem likely that access will be a major problem. Since MNOs cannot replicate such services, negotiations would relate to transport and data costs. However, as with TSPs, MNOs may be concerned about striking deals, which (could) then become the basis for subsequent negotiations under a possible non-discrimination obligation, should they be designated as having SMP (in that particular market).

Content owners may decide to subcontract billing to (non-MNO) third parties. This would reduce MNOs' potential revenue, but it would seem unlikely that this would pose an access problem, unless an MNO refused to provide an unbundled service to the content owner.

As in the current 2G/WAP environment providing 'access' to competing mobile portals could arise as an issue. Once a subscriber leaves its operator's mobile portal, and moves into the Internet, the MNO will become a bit pipe only. Since MNOs will be looking to maximise the amount of value added they retain the issue of 'walled gardens' could again emerge.

4.3.4 Value Added Mobile Service Providers

4.3.4.1 Definition and Service Offering

A potentially new type of SP could develop around MNOs' network facilities, particularly location data. Such SPs are likely to want to provide their service to an, or all, MNOs' customers. Given this, such operators would, in practice, be SPs to MNOs.

4.3.4.2 Likely Access Requirements

SPs would require access to:

- Mobility Management (System) data, particularly in relation to location data
- Application Program Interfaces (APIs) to allow them to write new (3G) applications.

Since the MNO would be the customer for such SPs, access would also be required to its (the MNO's) subscribers and mobile portal.

Table 14 Potential Value Added Mobile Service Provider Access Requirements

Core Network Entry Points			Network Intelligence		SGSN	Radio Access Network	Mobile Portal	MNO Subscribers
Internet		PSTN	MM	ASP				
GGSN	MGW	GMSC						
			X	(X)			X	X

4.3.4.3 Potential Access Problems

Problems are likely to focus on failure to agree commercial terms, since MNOs are likely to wish to secure a share of an SP's value added in return for access to both customers and customer data.



4.4 Market

4.4.1 Overview

In stable markets, it should be possible to address the access issues discussed in Sections 4.2 and 4.3 within the context of the Common Regulatory Framework. For the purposes of developing market scenarios we have, therefore, focused on 'extreme' market situations, which could challenge the regulatory 'status quo' established by the Common Regulatory Framework.

The ways in which MNOs develop, in general, and their approach to providing access to Service Providers, in particular, will vary, and reflect market developments in individual Member States. However, the decisions and strategies adopted in relation to the build out and commercial development of broadband networks and value-added services will be driven by the imperative to achieve a commercial return on investment. Whilst not all companies will have problems with their levels of debt (as a result, primarily, of licence acquisition costs), significant infrastructure costs will be common. There will, therefore, be considerable pressure to:

- reduce costs
- rapidly generate additional new value added revenue (for existing players) and voice and non voice income (for new entrants, which will have the additional costs associated with building a brand and customer base).

Existing operators will also be looking to maximise the return on 2.5G networks while testing the market with partial 3G networks (islands).

Against this background, we have considered *two* extreme market scenarios:

- a *low revenue* market, with little additional value added income for existing players, and insufficient revenue for new entrants
- a *high revenue* market, where take up of new broadband multimedia value services is significant.

In practice, it is probable that the actual market situation will:

- be somewhere between the two extremes
- reflect a combination of the two outcomes.

In the *low revenue* market scenario, MNOs will be driven by the need to reduce costs and increase revenue, with:

- cost reduction achieved via *horizontal integration* arrangements
- revenue increased, if possible, by *vertical integration* actions.



In the *high revenue* market scenario, the pressures to reduce costs by means of *horizontal integration* will be less, but there will still be a commercial imperative for MNOs to maximise income from the upstream elements of the value chain.

We have also assumed a *regulation-neutral* environment.

Each scenario:

- describes the reasons underlying the development of a particular supply-side structure
- examines potential access problems
- works through potential outcomes to highlight any regulatory issues arising from possible access problems identified.

4.4.2 Low Revenue Market - Vertical Integration

4.4.2.1 Market Situation and Player Motivation

As a result of insufficient revenue an MNO in a particular Member State has serious financial difficulties. As a consequence, the business is sold debt-free as a going concern to a consortium of upstream value chain players.

The consortium comprises a number of non-competing companies, and includes a financial services body (bank), a large retail organisation (a leading national supermarket) and an independent broadcaster.

Consortium members are motivated by:

- the opportunity to increase revenue and customer loyalty by leveraging their brands and customer bases (as in current '2G' arrangements)
- the need/desire to secure a digital delivery channel for their 'content', and gain a competitive advantage for their core business.

Since all consortium members have a large existing customer base, each implements an aggressive marketing strategy to move its customers from competing MNOs.

4.4.2.2 Potential Access Problems

Under this scenario, the key problem faced by regulators would be the change in the commercial objectives of the owners of an MNO.

Consortium members' focus would be on their core business, with mobile telecommunications a means of generating additional revenue (and customer bases) and increasing customer 'touch points'. Whilst the company would actively compete in the mobile telecommunications market against other MNOs, offering a similar value added proposition, it would not wish to be active in the wholesale market.

The impact of this change of focus would therefore be to reduce the capacity available to provide access to Service Providers, including MVNOs.



4.4.2.3 Regulatory Issues

Under this scenario, an NRA would be faced with a major policy issue in relation to the ownership of mobile networks, and have a number of options, almost all of which would have the potential to *increase* the level of regulatory intervention in the market, which would run contrary to stated EC policy (of applying minimum regulatory intervention).

If the NRA does not intervene, there would be a commensurate reduction in capacity available to Service Providers. Although this would, arguably, not be significant if only one MNO were to be affected, such an approach would become increasingly difficult to sustain if more MNOs were to be acquired and operated in a similar fashion.

If the National Competition Authority (NCA) or possibly NRA introduces a requirement into the 'terms of sale' that a new owner must offer wholesale services, this would, in practice, short circuit the SMP trigger in the Common Regulatory Framework, and would have to be applied to *all* the Member State's MNOs, effectively mandating third party access. Given the low revenue market scenario, such an approach is likely to result in incumbent MNOs actively seeking to reduce their costs (further) and (threatening) to cut back on future investment, as they would be unwilling to take on all the risk. In addition, in this situation, the MNO is unlikely to share in the value added.

At the same time, the introduction of such a requirement would probably result in an organisation or consortium deciding *not* to acquire the bankrupt MNO. If no other purchasers were interested, the MNO would close, resulting in:

- a reduction in capacity (with the licenced spectrum probably being returned to the NRA)
- immediate supply-side consolidation, which would increase the likelihood of one or more MNOs being designated as having SMP, permitting the NRA to intervene.

As an alternative, the NRA could allow the MNO to be acquired by an existing competitor. This is likely to lead to further supply-side consolidation, since the non-acquiring MNOs competitors would consider themselves at a competitive disadvantage to the acquiring MNO, which would rationalise its operations, benefiting from economies of scale. Therefore, they would probably seek to merge their operations. As a consequence, the likelihood of any MNO(s) being designated as having SMP would increase significantly, again permitting the NRA to intervene.

4.4.3 Low Revenue Market - Horizontal Integration

4.4.3.1 Market Situation and Player Motivation

As a consequence of financial pressures, the major MNOs in a Member State market face serious financial difficulties. As an alternative to corporate failure, the industry puts forward a sector restructuring plan, which is approved by the national government on the basis of its being in the 'public interest'.

The plan involves:

- the establishment of a stand alone infrastructure/network company



- the previous MNOs competing as MVNOs (over the common shared network).

This effectively splits (unbundles) the market into infrastructure (transport) provision and services.

Although the infrastructure business is established as a separate company, it has to work in close partnership with the previous MNOs as a means of sharing risk and reward, since without their involvement there is little motivation to invest.

4.4.3.2 *Potential Access Problems*

The existence of a single network infrastructure in a national market would potentially lead to significant access problems, since it would be operating as a private sector monopoly.

Although independent of the former MNOs, which established it, as highlighted, the need to share risk and reward to ensure the network is prepared to make necessary capital investments would require a close relationship between the network and former MNOs. This could lead to *tacit collusion* to prevent new SPs obtaining access.

On the other hand, a regulated infrastructure company would allow Service Providers to access a network on a non-discriminatory basis.

4.4.3.3 *Regulatory Issues*

This scenario would represent a significant departure from European Commission policy, which has been predicated on the need to have infrastructure competition as a means of providing the motivation for innovation, investment and cost reduction.

Regulatory authorities do possess powers under the competition law concept of dominance to address this issue, with the infrastructure provider clearly having SMP with *single company dominance*. In addition, the change in structure would require a higher degree of regulation, with sophisticated price controls to ensure the infrastructure company:

- continued to make investments (and innovate), whilst driving down prices
- was able to make a commercially attractive return for its investors.

Although this scenario assumes the creation of a single infrastructure provider, an alternative could be to:

- allow incumbent MNOs to limit their infrastructures/networks to agreed (non-overlapping) regions (with duplication in high traffic areas)
- mandate national roaming.

In theory, this structure could mean that each MNO would have SMP in its respective geographical region, which would facilitate third party access. As with the national infrastructure option, however, there would be a need for higher levels of regulatory intervention.



4.4.4 High Revenue Market - Vertical Integration

4.4.4.1 Market Situation and Player Motivation

There is significant demand for multimedia services from both the consumer and corporate market. Despite this, MNOs are still under considerable pressure to provide an attractive return to shareholders, reflecting the costs of licences (in some Member States), network build out and marketing.

In order to improve profitability, MNOs seek to secure a higher percentage of value added by entering into joint ventures with content providers. Although demand is high, capacity is not an issue, and MNOs see such arrangements as 'win-win', given the levels of competition (and costs), with at least one new entrant active on the market, which is likely to have captured share from the previous incumbents.

Content providers are motivated by:

- the opportunity to increase revenue and customer loyalty by leveraging their brands and customer bases (as in current '2G' arrangements)
- the need/desire to secure a digital delivery channel for their 'content', and gain an advantage over competitors.

Although content providers (large retail organisations, financial institutions, ...) initially adopt an Enhanced Service Provider model, an equally important element of the joint venture relationship is the opportunity to develop m-commerce services.

Due to the level of resources and commitment required, only large 'household name' organisations are involved, and since there are already high levels of intra-MNO competition – and no SMP, - MNOs do not enter into MVNO-type arrangements. In addition, all agreements are on an *exclusive basis*, which prevents the MNO from entering into agreements with directly competing organisations.

Joint ventures are the preferred vehicle for both parties as they are seen to represent an equitable means of sharing risk and reward. Acquisition is not a viable option for either party, since:

- MNOs' debt levels mean that acquisition of such significant non-core assets is not feasible (although acquisitions of smaller value chain players will remain possible)
- non-MNOs are not able/unwilling to acquire MNOs due to the size of their debt and, possibly, their perceived high risk.

4.4.4.2 Potential Access Problems

Under this scenario, problems could arise for national regulators if, for a given content provider type/sector:

- all joint venture agreements are established on an *exclusive basis*
- all MNOs have a joint venture relationship with a content provider



-
- the number of content providers exceeds the number of MNOs
 - non-linked content providers seek access, but are refused (because MNOs have already established exclusive arrangements with competitors).

4.4.4.3 *Regulatory Issues*

It is likely that NRAs would be able to intervene under the Common Regulatory Framework to ensure access.

Under the non-discriminatory pricing rules of competition law, the MNOs would be forced to provide access under similar commercial conditions to those of its joint venture, making it impossible to share in the value added.

If there is no SMP, it is difficult to see how an NRA could impose any obligations on an MNO *ex post*. However, this would mean that, in theory, competitors could be excluded from delivering their content via the mobile medium, and offering m-commerce facilities to customers.

From a competition law perspective, any exclusive agreements would be considered *restrictive*. This would allow NCAs (or occasionally NRAs) to intervene *ex post*, at a minimum. However, without SMP, there would still be no obvious requirement on MNOs to provide access to competing companies (to their joint ventures) on the basis of non-discrimination.

4.4.5 ***High Revenue Market - Horizontal Integration***

Under a high revenue market scenario, there will still be a commercial imperative to minimise costs. The need and desire to share infrastructure is more likely amongst a market's weaker players. In such instances, existing competition law under Article 81 (3) would come into effect. There may likewise be actual mergers between MNOs, but again, such developments would be subject to scrutiny (*ex ante*) under competition rules.



5. CONCLUSIONS AND RECOMMENDATIONS

5.1 Nature of Market

The mobile telecommunications market is undergoing a major change as MNOs move from:

- the provision of traditional voice telephony services, where they are able to exercise almost complete control over the value chain, to
- sellers of *value-added* multimedia services (which will still include voice), where, despite still controlling their own networks, their share of the value chain will be significantly reduced.

This paradigm shift is taking place against a background of *uncertainty* in relation to the economic returns achievable in an *untested* post-2G market.

In addition, businesses will be competing for personal and corporate users, who:

- are knowledgeable about, and demanding of mobile telecommunications services
- require, and are capable of identifying, value for money.

5.2 Commercial Environment

With new entrants in most Member States, overall competition has been increased. Mandatory national roaming will also allow new entrants to compete in the current 2G voice market, with commentators expecting them to use voice as a loss leader to build market share, with a knock-on impact on all service prices.

As a result, the financial pressures on MNOs will create a commercial imperative to:

- generate rapidly additional revenue by selling new value added services
- reduce costs.

In addition to (the option of) developing their own value-added services, there will be a strong motivation for MNOs to enter into commercial agreements with third party Service Providers, where they are able to achieve an equitable balance between each party's risk and reward. In a value-added service environment, there is no commercial rationale for an MNO to merely sell 'minutes', since they retain all the risk (associated with having developed a network) and none of the reward.

Given the costs incurred by MNOs to compete in post-2G markets and increases in competition in traditional voice markets, without being able to benefit from a sufficiently (large) share of an SP's margin on value added services, MNOs are unlikely to see a return on investment, and will, therefore, be reluctant to grant access.



5.3 Regulation

5.3.1 Potential Access Issues

5.3.1.1 Nature and Context

Regulators are likely to be faced with access problems in relation to:

- bottleneck network facilities to which potential SPs will require access in order to develop and deliver value added services
- supply-side developments, which may see MNOs moving towards *vertical integration* in order to increase their share of value added in a given market/service value chain and *horizontal integration* in order to reduce costs.

MNOs will be driven by the imperative to achieve a commercial return on their (significant) investment in 3G. Although the move to packet-switched IP-based technology could result in an open network business model, analogous to the existing fixed Internet, it will be in MNOs' interests to retain as much control over their subscriber base as possible.

5.3.1.2 Risks of Intervention

Given the uncertainty surrounding the commercial viability of 3G markets, they are likely to be highly sensitive to any (perceived) regulatory intervention. Although market players have clearly committed themselves to the market, any moves or decisions, which (appear to) threaten their ability to generate new value added revenue either themselves or through agreements with third parties could:

- cause MNOs to scale back investment
- precipitate/accelerate supply-side consolidation
- result in protracted legal disputes, during which time market development is likely to be held back as concerned parties await their outcome.

5.3.1.3 Risks of Non-intervention

It would seem unlikely that NRAs will be able not to intervene, as the financial attractiveness of the market for SPs (offering value added services) is likely to lead to disputes with MNOs over commercial terms. However, if this were possible, a 'worst case' scenario could see MNOs:

- not providing access to any third parties, instead providing all value added services themselves, with consumer choice and development of a competitive market hindered
- putting in place 'gardens', in effect limiting consumer access to competing mobile portals.



5.3.1.4 Conclusion

Irrespective of an NRA's preference for either intervention or non-intervention, they will:

- inevitably be called upon to intervene in access cases where commercial negotiations have failed
- have to intervene in cases involving horizontal integration (primarily infrastructure sharing).

Within the context of the (proposed) Common Regulatory Framework, they will have significant powers in relation to MNOs with SMP. *In our view*, it will be critical to this new value added market's successful development that:

- application of the rules be consistent across EU markets
- all parties 'buy into' an efficient and transparent dispute resolution process
- any intervention encourage involved parties to share risk and reward.

5.3.2 Common Regulatory Framework Implementation

The proposed Common Regulatory Framework will be broader and more flexible than existing legislation. However, as a consequence, it will be more complicated to interpret and apply, particularly since:

- NRAs will have to work in a competition law environment with which they are generally unfamiliar, *whilst*
- NCAs will have to become involved in a telecommunications environment, with which they are equally unfamiliar.

This lack of familiarity is a concern for market players, which would prefer (some degree of) *legal certainty*.

Although it is not NRAs' role to minimise organisations' business risk, the flexibility available to them in relation to the application of the significant powers in the proposed Common Regulatory Framework is likely to add to uncertainty. This and the increased complexity of reaching decisions under competition law in relation to SMP mean that there is a need for as great a degree of consistency between Member State approaches as is possible

In order to increase the *certainty* and *consistency* in the application of the proposed Common Regulatory Framework, *we recommend that* the European Commission work with either the Communications Committee and/or Higher Level Regulation Group to produce regular guidance papers ('soft law') based on peer reviews of its application.

5.3.3 Dispute Resolution

Experience to date indicates that disputes are more likely to be resolved by legal cases, which may end at the level of the European Court of Justice, rather than as a result of



intervention by NRAs. This creates uncertainty and can be to the detriment of the market's development, since the window of opportunity identified by third parties wishing to gain access may (is likely to) be very small, such that failure to secure access at a particular time destroys its business case.

In our view, in rapidly moving mobile telecommunications markets, it will be critical to have a dispute resolution process within which all parties accept an NRA's decision as binding, rather than pursue additional litigation. This requires all parties to 'buy into' and commit to the process. Given this, *we recommend that* NRAs actively explore the use of self-regulation, whereby MNOs are mandated to develop (self-regulatory) codes in relation to access, which would include the handling of disputes, or co-regulation, whereby industry representative bodies are mandated to produce the same.

This approach need not necessarily be limited to dispute resolution. It could possibly be applied in relation to terms and conditions relating to access, which could, in turn, reduce the number of disputes, which NRAs are required to handle.

5.4 Risk and Reward in Value-added Markets

The application of the non-discrimination obligation to an MNO with SMP in relation to the provision of access to an SP could have significant negative consequences for market development. From a commercial perspective, it is in an MNO's interests to enter into joint venture-type agreements with SPs, whereby it is able to secure a share of the value added 'in exchange for' the risk incurred in developing the network. There is a wide range of possible SPs, with different potential access requirements. Non-discrimination, in contrast, assumes all third parties (SPs) are alike, which, in a value-added market, would not be the case. The potential threat of (application of) the non-discrimination obligation could therefore cause MNOs not to enter into innovative agreements with niche SP out of concerns that they will be required to offer the same terms and conditions to other – different – SP.

Whilst Article 13 of the A&ID requires NRAs to take account of MNO's investment costs and the need to safeguard competition in the long run, should a cost-based pricing obligation be imposed, calculation of a reasonable rate of return in an immature value added market will be far from simple.

In our view, in a market, which is based on added value and where, by definition, there is no standard 'bit' price, MNOs should be able to price according to the value of the service being provided over its network. Such an approach would establish the basis for true market pricing on an ongoing basis, which, in turn, should facilitate sustained competition in the long term. It would also overcome the potential negative impact of artificially 'fixed'/standard prices, which could result from regulatory intervention, and which would not reflect the reality of rapidly developing value added markets.

Even so, it is likely that NRAs will become involved in disputes in relation to commercial terms. There may be a value in exploring the possibility of developing a 'mediation tool', which uses a sliding scale methodology linked to the SP's 'service margin' over and above 'air time', whereby an MNO's revenue increases in proportion to the SP's value added margin. Although, inevitably, artificial, this could encourage the market's development by facilitating 'win-win' agreements and making MNOs with SMP less inclined to develop methods of avoiding regulation, which, in itself, would be counter-productive.



APPENDIX I. ORGANISATIONS INTERVIEWED

<i>Organisation</i>	<i>Role</i>	<i>Member State</i>
INTUG	Consumer Organisation	International
Yahoo! Europe	Content Aggregator	Europe
Bertelsmann Content Network	Content Provider	Germany
Visa	Credit – Commerce	International
Virgin	ESP	UK
OneTel	ESP/MVNO	The Netherlands
Ministry of Transport & Communications	Govt Ministry	Finland
Ministry of Economic Development	Govt Ministry	New Zealand
ECTA	Industry Body	Europe
ETNO	Industry Body	Europe
ETP	Industry Body	Europe
GSM Europe	Industry Body	Europe
GSM Association	Industry Body	International
IPv6 Forum	Industry Body	International
UMTS Forum	Industry Body	International
Crown Castle International	Infrastructure Provider/Operator	International
ABN-AMRO	Investment Bank/ Analyst	International
AOL Europe	ISP	Europe
Liberty Surf	ISP	France
Terra-Lycos	ISP	Spain
World Online	ISP	UK
Hewlett Packard	IT	International
Alcatel	Manufacturer	International
Ericsson	Manufacturer	International
Nokia	Manufacturer	International
Siemens	Manufacturer	International
DNA & Suomen 3G	MNO	Finland
Sonera	MNO	Finland
Telia Mobile (Finland)	MNO	Finland
Bouygues	MNO	France
Cegetel-SFR	MNO	France
France Telecom Mobile	MNO	France
D2 Vodafone-Mannesmann	MNO	Germany
Group 3G	MNO	Germany
T-Mobil	MNO	Germany
Viag Interkom	MNO	Germany
Omnitel	MNO	Italy
Telefónica Móviles	MNO	Spain
Xfera	MNO	Spain
BEN	MNO	The Netherlands
Dutchtone	MNO	The Netherlands
KPN Mobile	MNO	The Netherlands



<i>Organisation</i>	<i>Role</i>	<i>Member State</i>
Libertel	MNO	The Netherlands
BT Wireless	MNO	UK
One-2-One	MNO	UK
Orange plc	MNO	UK
Vodafone UK	MNO	UK
Hutchison 3G	MNO (3G licensee)	UK
Imagine	MVNO	Ireland
Energis	ESP/MVNO	UK
Sainsbury's	ESP	UK
Tele2	MVNO/MNO	Denmark/ Luxembourg
TKC	NRA	Austria
BIPT	NRA	Belgium
Telestyrlesen	NRA	Denmark
TAC	NRA	Finland
Reg TP	NRA	Germany
EETT	NRA	Greece
OFTA	NRA	Hong Kong
ODTR	NRA	Ireland
AGCOM	NRA	Italy
ILT	NRA	Luxembourg
NPT	NRA	Norway
ICP	NRA	Portugal
CMT	NRA	Spain
PTS	NRA	Sweden
OFCOM	NRA	Switzerland
OPTA	NRA	The Netherlands
Of tel	NRA	UK
Wireless Bureau of the FCC	NRA	USA
ACCC	NRA/NCA	Australia
Wappup	Portal	France
Wapamente	Portal	Spain
Ya	Portal	Spain
IOBox	SP	Finland
Jippii Group	SP	Finland
Wapit	SP	Finland
Debitel	SP	Germany
INMS	SP	UK
ETSI	Standardisation Body	Europe
privacom	Telecoms start-up	International



APPENDIX II. INTERVIEW PROGRAMME ANALYSIS

II.1 Overview

Interviews were conducted as open-ended discussions using a semi-structured questionnaire, with topics adapted as necessary according to organisation and interview. For example, with NRAs, more time was devoted to current access regimes.

The profile of organisations interviewed is shown in Table 1 of the report.

The following sections outline key issues arising from the interviews.

II.2 The Future Value Chain

Interviewees considered that the future value chain would become more complex and that there would be a number of different models employed. In 3G, interviewees confirmed that there will be greater ability to differentiate in the *services domain* and this is where competition should take place.

“Partnering” with the range of new players entering telecoms was widely seen as critical for allowing MNOs to develop the required range of services to compete in the post-2G environment. MNOs’ own businesses were expected to progress by developing services based around their current core offerings. A range of interviewees thought that if new players were able to offer true value added services, access to the market (via MNOs) would not be a problem, as there would be a “win-win” situation where both MNO and third party would benefit.

Non mobile-network owning organisations emphasised, however, that “adding value” implicitly means “adding value to the MNO’s service offering”, whereas they would prefer being able to *source inputs* from MNOs (networks) and construct their own services. Some equated this kind of concept with local loop unbundling in the fixed market. Third parties would, in this model, be independent competing *services* organisations.

One organisation strongly disagreed that MNOs are actively pursuing the partnering model, whilst another emphasised that even within partnership agreements, the MNO will be able to retain the controlling influence, because of the power they are able to bring to the negotiating table. Several interviewees also cited experiences to date as a better indication of MNOs’ future approach (“actions speak louder than words”: high call termination and roaming rates, WAP locks (walled gardens), SIM locks...). In particular, continuation of an “ownership” mentality was seen as a stumbling block. If such a mentality prevailed, it was felt that the resulting markets would be oligopolistic in nature.

In order to avoid direct conflicts with MNOs’ interests, several respondents suggested that potential MVNOs will have to be focused on, or address niche markets, which in some way complement MNOs’ businesses. Such an approach would not have such a detrimental effect on MNOs’ planned *investment strategies*, which were cited as key concerns relating to the development of MVNOs. Some, however, thought that the full MVNO concept was not



viable, as it competed too directly with MNOs' core business, and expressed a preference for the less integrated "Enhanced Service Provider" concept.

Several interviewees thought that the most logical candidates for MVNOs were existing fixed-line operators wishing to supply converged fixed-mobile services, which was one benefit to the market cited by potential MVNO respondents. One NRA expressed the view that it was not yet clear how fixed operators would react if MNOs moved increasingly into the fixed arena, where access could be seen as easier. However, some non-network organisations regarded it as unfair (if not to say anti-competitive) that MNOs seemed to be willing to enter into agreements only with organisations that have existing brands and customer bases.

Several respondents questioned the number of MNOs that will be able to be supported in the future, noting that consolidation may continue as a result of market pressures. In order to be successful, a variety of strategies were identified, including "voice-only" UMTS services, and open networks with MNOs merely acting as "carriers" (bit pipes).

Some interviewees thought that if the "mobile internet" experience becomes similar to that on fixed connections, network operators will automatically be relegated to a "transport" role (as on the fixed market).

Horizontal consolidation and internationalisation were widely expected to continue, with the emergence of 3-5 pan-European groups. In some cases, this was seen as having implications for regulation and regulators.

Vertical integration was also seen as a developing trend, not just within telecommunications (service provision, distribution channels), but also across sectors, as access to content becomes more important. Some interviewees foresaw the development of integrated conglomerates supplying content and delivering services.

Within the industry, some non-network organisations pointed out that even if MNOs' service provision and network organisations are legally separated, in reality, they act as vertically integrated entities. Contrasting this was the experience from another non-network organisation whose negotiations had become considerably easier where functions within MNOs had been separated. For example, marketing/network management functions were still seen as protecting the "old" business model, whereas commercial teams were more free to agree contracts attracting traffic to MNOs' networks.

II.3 Future Value Added Services

II.3.1 Overview

Although most interviewees saw the market's development as an evolution from the current 2G environment, many players pointed out that the market's route into the 3G environment is unclear, with a range of business models likely to be employed, and success of 3G services far from certain. One interviewee expressed the view that only a selection of these will be able to survive



The nature of 3G services is also unclear, although one MNO indicated that they will be much more than simply “GSM plus”. No single killer application has yet been identified, but interviewees regarded the following as likely to emerge as successful:

- m-commerce
- location-based services
- messaging/e-mail
- entertainment and music.

Banking services were also viewed as a natural development for MNOs.

A number of MNOs pointed out the importance of the development of micro-payment systems and electronic wallets for m-commerce where credit card transactions are still not convenient. However, methods of distributing revenues between the various players involved in the supply of services, and of finally billing the consumer were cited as key areas requiring development.

II.3.2 Importance of Content

A variety of players emphasised the importance of content in delivering services. Some foresaw this as leading to content providers moving into the telecoms market. Others again cited MNOs’ need to partner to enhance their expertise in this area. One respondent thought that vertical integration would help delivery to the consumer. However, some interviewees pointed out that large content providers are not exclusively focused on “mobile”, seeing it as simply an additional delivery channel.

II.3.3 Carrier-Selection/Preselection

One non-network owning organisation suggested that carrier selection could lead to reduced prices for consumers. Two MNO interviewees stressed that carrier selection or preselection were not seen as beneficial for the mobile market, since the reasons for their introduction were not seen as compelling compared to the fixed market. For example, there is already a choice of infrastructure on the mobile market.

II.3.4 Technology

Whilst most interviewees were optimistic regarding the ability of vendors and network operators to overcome technical challenges, the following were identified as outstanding issues:

- header compression in the transfer to IPv6
- data protection associated with the increasingly complex value chain as customer information is exchanged between organisations
- network integrity and security for m-commerce.



Some interviewees stressed that (cellular) mobile communications should also be seen in the wider light of the other technologies that will also have a significant role to play in the future communications environment. Examples included in-building use of Wireless LANs (WLANs), development of the Wireless Local Loop (WLL), or direct competition in certain market segments from TETRA.

In addition, the consumer was expected to be more interested in the type of services available, and issues like price and ease of use, rather than the particular technology platform employed. Examples given illustrating different delivery mechanisms included:

- audio content delivered by CD/DVD, internet download, broadcast...
- data, where a user's device automatically switches between the most appropriate technology, employing WLAN in the office environment, then transferring to 3G/2.5G networks as the user moves outside
- retailers setting-up powerful Bluetooth transmitters on unlicensed spectrum to advertise on local handsets.

II.4 3G Market Development – Critical Success Factors

Interviewees most commonly cited the following factors as having the potential to hamper the introduction of 3G services:

- *device availability*
- *stable standards* – once standards are in place there should be no problem. Whilst recognising the amount of work carried out within the 3GPP, some MNOs pointed out the late stage at which standardisation was still taking place (in relation to rollout). This was contrasted to GSM (notwithstanding modification requests), which had been in place some time before rollout, especially for later market entrants
- *compatibility* - some interviewees cited lack of compatibility between different manufacturers' equipment as causing problems. Industry bodies and manufacturers maintained that these issues were in hand, using measures such as inter-operator testing programmes
- *sensitivity to regulatory intervention* - several MNOs pointed out the market's sensitivity to regulatory intervention, and urged restraint while the market is established. Some MNOs even saw it as the role of each Member State's largest players to develop the 3G market before other players make similar commitments
- *planning regulation* – a number of MNOs and manufacturers expressed the view that network rollout would be impeded if steps were not taken to ensure that MNOs were able to obtain sufficient planning regulation.



II.5 The Nature and Role of Regulation

II.5.1 Overview

Several market players stressed that regulation should not be used to create a specific market structure, as it would not be as effective as the effects of competition and innovation. Imposed solutions would generally be seen as heavy-handed and inappropriate due to the market's speed of change. Hence some interviewees stressed regulation's *facilitating* role in market development, rather than implementing a prescriptive regime.

Several interviewees identified the requirement to find the correct balance between “carrot and stick”, such that both are the right size and shape to promote a fully competitive market without risking “closing down” the market. MNOs especially indicated that use of *competition law* should be the preferred tool of regulators.

A number of interviewees stressed that regulatory bodies, including the European Commission, should consider the aims and “philosophy” of any proposals in terms of:

- balancing risk and reward when introducing of new players
- looking from the consumer's viewpoint, and not just the regulator's
- taking account of the benefit transferred to Member States' economies by the industry.

This should also include very careful consideration of what is trying to be achieved, or what particular market feature is being corrected with regulatory measures. It was pointed out that NRA intervention seemed to focus on opening up successful produce/service markets to third parties. Some felt that this approach failed to recognise the commercial reality, that, for each success story, there are (far more) failures, with the former compensating for the latter. This was seen as especially problematic for MNOs, which have tried to introduce “packages” aimed at specific market segments (“lifestyles”) that have a range of product elements within them.

II.5.2 Role of NRAs

Several NRAs made it explicit that their role was not to create a particular type of market, preferring to use a “light touch” or “hands off” approach. Market players were keen to see this approach adopted, with some arguing that the 3G market should be allowed to develop in some “breathing space” before any extensive regulatory measures are imposed. Several interviewees cited the example of the environment created by the Danish NRA, where a change to the regulatory regime has led to the (commercially negotiated) introduction of a full MVNO. This change has been applied to the whole market and is not a set of particular measures aimed at a few selected market players.

A number of interviewees stressed that the market's development would also depend on NRAs' implementation and interpretation of the proposed framework. Some, however, had strong views on the need for NRAs to *effectively enforce both current and future regulatory packages* and competition law. Others also questioned NRAs' true level of independence from political influence via Member State governments. In at least two Member States, the



NRA's recommendations on UMTS Licence Award process were not taken up by their respective ministries.

Several interviewees identified the continuing need for NRAs to ensure that national incumbents (PTOs) are made to comply with obligations, complaining of "scandalous" behaviour from these organisations in using tactics to prevent the opening-up of markets.

II.5.3 SMP and Market Definition

Several interviewees, including some NRAs, thought that *market definition* would present problems in the 3G environment due to the degree of complexity involved. *Joint dominance* was viewed by some as being particularly ill-defined and practically impossible to prove. Other interviewees identified a general requirement for more specific definitions in order to aid legal certainty in the regulatory programme. Guidelines (for NRAs) from the European Commission were welcomed by both industry players and NRAs. Some NRAs felt that market definition should remain firmly within their remit (with no transfer of responsibility to the Commission), whilst MNOs stressed the need for harmonisation/consistency between Member States.

Several interviewees also thought that the "essential facilities" doctrine would become increasingly relevant as new players attempt to enter the market.

A number of market players emphasised that just because large organisations exist in the industry, abuse of this position doesn't necessarily follow: the industry is inherently concentrated, making use of scarce resources and requiring high levels of capital investment. Therefore, regulation should attack *market failure*, and not concentrate on the *size* of undertakings.

One MNO emphasised the view that SMP (and subsequent obligations) can only be applied to the largest players in a market, who would, therefore, be more likely to experience any capacity constraints.

II.5.4 Independent Regulators Group

NRAs identified the (informal) environment provided by the Independent Regulators Group (IRG) as an important way of enhancing harmonisation through exchange of views and development of co-operation based on previous experience.

II.5.5 3G Timetable

Three MNOs suggested that the overall timetable for the introduction of UMTS services had been imposed too soon, with initial consultations taking place whilst many were still building up the 2G market, and later entrants had not even commenced operation.

II.5.6 Fixed versus Mobile Telecoms Regulation

Many industry players opposed what was seen as the application of fixed market regulation to mobile telecommunications. They urged mobile to be seen in a different way, having developed in a different manner compared to the fixed market's transfer from monopoly.



II.5.7 Handset Subsidisation

Several market players identified handset subsidisation as a distortion of the market, as it blurs the boundaries between the different market roles, and can effectively be used as a tool for cross subsidisation. One MNO, with a national market share of around 30% claimed to have tried to discontinue the practice, but had been unable to do so, which, it considered, proved that it did not have market power.

II.5.8 Requests for Access

A wide range of interviewees, including non-network owning organisations thought that access to mobile networks should come about *through commercial negotiation*, not imposition by regulatory bodies. A number of MNOs thought that this would occur without any problem, due to the number of network operators present on the 3G market, who would be embracing partnering, and trying to attract traffic to their networks. One MNO suggested that a “market” for access will develop because of competition between MNOs. Several thought that once access had been granted by one MNO in a Member State, others would follow.

In cases where third party access had begun to be successful, MNOs especially stressed the sharing of risk, with one possible route to ensure no conflict of interest being the setting-up of joint ventures. Both MNOs and non-network organisations argued that the ability to capture churn from other networks via a third party’s customers was being seen as increasingly attractive for MNOs.

However, non-network organisations, in particular, identified problems even where access had already been granted, such as poor supply of billing records, or extraordinarily long periods for traffic forecasts. Whilst these organisations accepted the mantra “healthy MVNOs need healthy MNOs”, such that there must be sufficient incentive to build out networks, with a justifiable rate of return, some felt that MNOs’ first mover advantage should not be allowed to exclude other players. One argued vigorously that MNOs were leveraging their power from the infrastructure market onto the services domain, which should not be permitted by NRAs.

Some non-network organisations also pointed out that considerable investment can be required in order to supply services via access to mobile networks, for example, purchase of switching equipment or gateways. In some cases, this investment has been rendered uneconomic by MNOs’ reluctance to conclude agreements or provide access. The *realities* of the current regulatory environment, *for which NRAs are responsible*, were cited as providing insufficient *legal certainty* for third parties requesting access. Several respondents thought that this was unlikely to change in the new regime, based on the proposed legislative documents.

In this sense, those requesting access stressed that the continuing development of third parties obtaining access to mobile networks is not just a commercial decision, but also a *political* one, because clear guidance is necessary from bodies, such as the European Commission, on the interpretation and implementation of legislation.



II.5.9 Types of Access

Types of access that could be requested were specified as including billing information, location data, application hosting, other network intelligence, or (“conventional”) interconnection.

Several non-network owning organisations thought that the traditional “service provider” (reseller) role from the 2G environment is likely to disappear in 3G. The simple “access” function to the internet from mobile devices was also a role identified as one that will be subsumed into MNOs’ activities, especially when services enter the “always-on” domain. One NRA made it clear that should this happen, this was not a regulatory issue, being the result of market dynamics.

One *independent portal* interviewee confirmed that they (portals) do not strictly need access to a mobile network, but to potential users. Given this, MNOs have a role to play in facilitating or hindering user access to portals’ services. MNOs are able to prevent independent portals reaching users, and may also use measures to promote their own, preferred, solutions. This can take place even without the full “walled garden” mentality, for example, by making it extremely difficult (but not impossible) for users to change default portals.

II.5.10 Cost Orientation and Non Discrimination

Market players were generally opposed to the imposition of cost-based obligations, with the most vigorous opponents calling it the “Nuclear Bomb” of regulation. Non-network owning organisations also preferred agreements reached by commercial negotiation, although two supported it for its possible effect in reducing barriers to entry. A number of MNOs also expressed the view that the potential application of the non-discrimination obligation was a disincentive to entering into deals with third parties.

Those opposed criticised it as impeding competition, and for its *de facto* effect of regulating other players in the market. For example, imposition of call termination charges on MNOs with SMP would, it was argued, lead to smaller players having to follow suit. One MNO also noted that current models are not very well-conceived, as Long-Run Incremental Costs (LRIC) implied a level of certainty that does not yet exist for 3G.

II.5.11 Licensing and Spectrum

A number of interviewees argued that UMTS licence award processes have distorted the future 3G market:

- high costs in the largest Member States have removed large amounts of capital from the industry, and have effectively served to *tax* the industry’s future revenues. Some interviewees expressed the desire for some move from Member States to re-introduce this money into the industry. Non-network owning organisations thought that high licence fees could either make MNO licensees more open to partnering, or pursue a strategy of “squeezing” third parties (even) more, because of the increased difficulty in making returns on investment. Some thought that an inevitable result of these processes was that the consumer would have to pay more for 3G services



- the decision in some Member States to distribute licences at very little cost has put their existing MNOs in relatively strong positions, making it easier for them to bid for licences elsewhere
- conditions associated with licences, such as differences in roll-out commitments and the amount of spectrum per licence in different Member States, will not promote harmonisation. One MNO made it explicit that if *regulatory* harmonisation is to be encouraged, licence conditions should not have been allowed to diverge. Differences in conditions were, however, also acknowledged by others as Member States being able to reflect their specific markets and geographies.

Two interviewees also pointed to the case of the Swiss UMTS auction (where two potential bidders were bought by another shortly before the auction commenced, preventing any escalation of bids) as a sign of distortion within the licensing process.

One UMTS licensee raised doubts about its ability to provide all the 3G services it desired with the spectrum available. A number of MNOs and manufacturers raised the issue of requirements for further spectrum, such as extension bands. Harmonisation work internationally, and Member State actions to relocate existing users if necessary were considered important in ensuring access to sufficient spectrum, and overall spectrum efficiency. One interviewee compared current licensing arrangements set up by governments as timetabling a train that would only pass every fifteen to twenty years.

However, other MNOs confirmed that they were satisfied with licence award outcomes (both in terms of cost and spectrum allocation), having considered all possible outcomes before awards took place. One MNO even suggested that high licence fees should have been increased still further to eliminate weaker business plans.

II.5.12 Dispute Resolution

Many interviewees cited the imperative for short dispute resolution times, to prevent one party “winning by default”, for example, a business model no longer being viable because market conditions had changed. Responsibility for this area was seen to lie with NRAs, although some interviewees would welcome any enhancement of the Commission’s abilities in order to handle disputes with pan-European significance. Lengthy investigations taking one to three years were seen as useless for an industry moving as quickly as mobile communications. One interviewee even suggested dispute resolution times of no longer than three months.

Several interviewees cited the need for NRAs to carry through decisions effectively, and to impose effective sanctions, such as turnover-related fines, for non compliance, if necessary.

II.5.13 Network Financing

Manufacturers have been seen to be open to varying degrees of commitment, in order to help finance 3G networks. However, some highlighted the significant additional risk this has passed on to manufacturers, and would prefer to see manufacturers’ and network operators’ responsibilities remain distinct.



Others argued that greater account should be taken of the financial markets' influence on telecommunications, especially in terms of shareholders' sensitivity to results of possible regulatory measures.

II.5.14 Infrastructure

A number of interviewees expressed serious concern over the “backlash” movement which was making it more difficult to build out infrastructure. They objected to the importance that was being given to opinions which are seen to be chiefly subjective (fears of health risks, “not in my back yard” attitudes). Numerous interviewees stressed that the debate on health aspects of mobile communications should progress on evidence, rather than subjective fears about “radio smog”, for instance. It was argued that it was incongruous for Member States to claim to promote mobile telecommunications and retain licence fees, when, at a local level, the situation was becoming increasingly difficult.

Several MNOs emphasised that infrastructure competition had been successful on the 2G market. However, two of these have since announced infrastructure sharing agreements. Some saw their networks as a competitive advantage, and which they would not want to lose by providing enforced access to other organisations. Those countering this argument cited the fact that standardisation ensures that the consumer is oblivious to infrastructure characteristics, and that competition should, in any case, be taking place on the services domain.

It was generally felt that any moves towards infrastructure sharing would have to be carefully analysed, and should not have the effect of protecting weaker MNOs through lowered costs which could protract their exit from the market. Several NRAs regarded infrastructure sharing as a matter for commercial agreement, providing that competition was not compromised, and would, therefore, be taking a pragmatic approach. Some MNOs stressed that infrastructure sharing would be inevitable in the current financial climate, and that Member State governments should embrace the idea.

Interviewees identified different levels of infrastructure sharing ranging from site and mast sharing, to joint ownership of networks, with antenna sharing and selective build-out (with national roaming) in the middle.

Two further alternatives proposed were:

- outsourcing – independent companies supplying, operating and managing infrastructure. This was stressed as being different to manufacturers taking responsibility for supply and management of infrastructure (“turn-key” solutions). Outsourcing companies, sometimes referred to as “mast-” or “tower-“ companies, would aim to specialise in the transport sector of the market, attaining cost savings by providing solutions for multiple operators. Supporters of this model pointed to the broadcast industry and Internet access environment, where service provision does not rely on infrastructure provision to differentiate itself
- establishment of an independent company for operating and managing infrastructure (“Netco”). This would be similar to the joint venture idea outlined above, except that management of the network would now be out of the hands of MNOs. Again, all operators would effectively become MVNOs on the new network, and questions of spectrum ownership would need to be addressed.



Interviewees pointed out that, even if infrastructure sharing did not provide an *ideal* solution, it would be a *better* solution than forcing MNOs to construct individual networks in an uncertain environment. Although complete sharing was unlikely, several interviewees predicted the formation of (MNO) consortia to develop solutions.

Non-network owning organisations also agreed that network sharing had certain compelling arguments, but that it would not necessarily help access requests, and should be carefully monitored.

To combat the difficulties in obtaining access, some organisations, suggested that infrastructure provision and operation should be mandatorily divorced from service provision. Such a measure, it was hoped, would lead to:

- the construction of as many network infrastructures as a region could economically support, with several infrastructure providers, who could respond to demand and capacity constraints, minimise waste and environmental impact. Such organisations' incentives would be the need to attract traffic to networks
- a competitive services market with a range of players accessing infrastructure facilities.

Suggestion of the more extreme situation of a national infrastructure company ("Netco") were viewed variously, as this would again be creating a monopolist organisation, requiring careful monitoring, and could impact on (existing) competition at various levels of the infrastructure market. One MNO welcomed this solution, however, citing minimised environmental impact, costs and rollout times as potential attractions.

In order to show how seriously these ideas are being addressed elsewhere, one interviewee pointed to Malaysia's 3G consultation document, where a unified infrastructure with separate service-based organisations had been suggested. One non-EU NRA also pointed out that their 3G licence awards will, in fact, reduce the number of operators, and introduce an "Open Network" policy (where 30% of network capacity must be supplied to non-host organisations, capacity permitting), together with *encouragement for SMEs to supply 3G services*. This is in contrast to several interviewees' confirmations of (some) MNOs' position that that MVNO-type access will *only* be granted to organisations with strong brands and existing customer bases.

II.5.15 Role of the European Commission

Interviewees saw the European Commission as having an important role in:

- promoting application of best practice, in particular in EU efforts to achieve harmonisation. Several interviewees expressed the view that the limited knowledge management between NRAs and NRAs' different interpretations of legislation were a problem. Some saw the Commission's role as a focal point for the industry, for example, further co-ordinating research on health risks, or benchmarking developments within the industry
- providing effective guidance to Member States and NRAs. Several interviewees, (both MNOs and SPs) expressed disappointment that the Commission's veto on NRA measures was not retained in the regulatory package



-
- acting as an effective interface between regulatory, operator and other industry bodies
 - dealing with issues that have Union-wide implications, such as roaming, and emerging pan-European groups (and, of course, harmonisation). This would become increasingly important as many interviewees confirmed that markets had been chiefly national in focus so far.

Some interviewees stressed the Commission's potential to *facilitate* the success of the 3G market by focusing attention on the fact that if manufacturers and MNOs are not allowed to build the market's momentum, talk of regulatory approaches will be academic. In a successful market, a "win-win" scenario could be envisaged for all – governments (via purchase taxes on services) and market players (larger market equates to more opportunities all round).

Interviewees from all sections of the industry stressed the need for regulators and the Commission to consider policy goals in terms of the overall benefit conferred on consumers and regional welfare derived from the industry. Several interviewees stressed looking at the "big picture", and accepting that future developments would be both trans-sectoral, for example, m-banking, and on a greater international stage.

Different views were expressed on the possible role of a European Regulatory Authority, with some MNOs and SPs attracted to particular aspects of the idea, such as the guaranteed harmonisation it would provide. NRAs were generally less positive to the idea, seeing it as an (unnecessary) centralisation of authority.



APPENDIX III. MNO-SP AGREEMENTS

The following table provides an overview of the main Service Provider agreements identified at the end of March 2001, based on information obtained from desk research and provided by operators.

<i>Member State</i>	<i>Network Partner</i>	<i>Network</i>	<i>Service Provider (Commercial Name)</i>	<i>Type of Organisation</i>	<i>Established</i>	
Denmark	TDC Tele-Danmark Mobil A/S	2G	Duet	Fixed Operator	September 1997	
	SONOFON A/S	2G	Sense Communications A/S (Sense Mobile)	Service Provider	October 2000	
			Tele2 A/S DuoFon	ISP Fixed Operator	October 2000 May 1999	
Finland	Radiolinja Oy	2G (GSM 900)	Telia Finland Oy	2G MNO (1800 Mhz)	November 1999	
	Sonera Oyj	2G	RSLCom Finland Oy	Fixed Operator	January 1999	
			Jippii Group Oyj (Jippii GSM) Saunalahti Oyj (Saunalahden Serveri)	ISP Fixed Operator	Q3 2000 March 2000	
France	SFR	2G	Télécom Carrefour	Retailer	July 2000	
			Debitel France Futur Telecom SAGEM SCS Coriolis Télécom	Service Provider Service Provider Service Provider Fixed Operator		
	Orange France	2G	CMC Telecom SAGEM SCS Coriolis Télécom	Service Provider Solutions Provider		January 1993
			Debitel France Intercall	Service Provider Fixed operator		July 2000
Bouygues Telecom SA	2G	Debitel France CMC Telecom	Service Provider Service Provider			
Germany	E-Plus Mobilfunk GmbH	2G	Cellway D-Plus Telecommunications GmbH Victorvox AG TelePassport AG Talkline GmbH RSLCom Deutschland GmbH Group 3G Hutchison Telecom Debitel AG	3G MNO Service Provider	April 2001 April 2001	
			Mannesmann Mobilfunk GmbH (D2)	2G	Cellway Talkline GmbH Debitel AG Victorvox AG	Fixed Operator Service Provider



Member State	Network Partner	Network	Service Provider (Commercial Name)	Type of Organisation	Established
			Netzel Plus AG		
Germany	Mannesmann Mobilfunk GmbH (D2)	2G	Mobilcom AG D-Plus Telecommunications GmbH		
		3G	Hutchison Telecom		
	T-mobil GmbH (D1)	3G	Debitel AG	Service Provider	
		2G	Debitel AG Victorvox AG Talkline GmbH Cellway Netzel Plus AG RSLCom Deutschland GmbH D-Plus Telecommunications GmbH Mobilcom AG Hutchison Telecom	Service Provider ISP	1991
Greece	Panafon-Vodafone SA.	2G	Citicom SA Unifon Panafon Emporiki NextNet Radio Korassidis Telecom Mobitel	Retailer ISP Retailer Retailer Retailer	1998 December 1997 1993 1993 February 1999
Ireland	Eircell Ltd.	2G	Budget Telecom Cellular 3 (imagine Mobile)	Fixed operator Fixed operator	August 1997
	Cellular 3 (Eircell Ltd.)	2G	Spirit Telecoms (Spirit Mobile)	Fixed operator	August 2000
	Esat Digifone Ltd	2G	Budget Telecom	Fixed operator	
Netherlands	Libertel Netwerk BV	2G	UniqueAir Nederland Socratel	Service Provider	1996 May 1997
			Intercity Mobile Communications Talkline Benelux	Fixed Operator	
	KPN Mobile The Netherlands NV	2G	One.Tel Netherlands	Fixed Operator	November 2000
Spain	Retevisión Móvil SA (Amena)	2G	Euskaltel (Euskaltel Mobile)	Fixed Operator	January 1999
	Airtel Vodafone SA	2.5G	XFERA Móvil, SA	3G MNO	May 2001
	Telefónica Móviles SA or Airtel-Vodafone SA	2/2.5G	Affinalia	Service Provider	April 2001
Spain	Telefónica Móviles SA or Airtel-Vodafone SA	2/2.5G	Primus Telecomunicaciones Ibérica SA	Fixed Operator	April 2001



Member State	Network Partner	Network	Service Provider (Commercial Name)	Type of Organisation	Established
			Timón Comunicaciones SA (Abbla Mobile)	Fixed Operator	April 2001
			Vallehermoso SA (Vallehermoso Telecom)	Fixed operator	April 2001
			Avirón	Fixed operator	April 2001
			Aló Comunicación	ISP	May 2001
			Globaltel	Service Provider	May 2001
			BT Telecomunicaciones	Fixed Operator	May 2001
Sweden	Europolitan-Vodafone AB	2G	Glocalnet	Fixed Operator	December 2000
			Blue Factory	Service Provider	December 2000
			Sense Communications (Sense Mobile)	Service Provider	December 2000
			HemEl	Fixed operator	January 2001
	ICA Marknad	Retailer	February 2001		
	Mobyson	Fixed operator	February 2001		
Lunarworks	Service Provider	February 2001			
Telia Mobile AB	2G	Wireless Maingate (M2M)	Service Provider	1998	
		Song Networks AB	Service Provider		
Tele 2 AB	3G	Sense Communications (Sense Mobile)	Service Provider	April 2000	
		Telia Mobile AB	2G MNO	March 2001	
		2G	Telenor [Norway]	2G MNO	2001
		2G	Dial n'Smile		
UK	One-2-One Personal Communications Ltd	2G	Virgin Holding plc (Virgin Mobile)	Multiple interests	June 1999
			Carphone Warehouse (Fresh)	Retailer	December 1999
	BT Cellnet	2G	Kingston Communications	Fixed Operator	January 2000
			J Sainsbury (Sainsbury's One)	Retailer	October 2000
			Carphone Warehouse / FT (FT Mobile)	Retailer / Media	March 2001
One.Tel Netherlands	Fixed Operator	June 2001 (proposed)			
Vodafone UK	2G	Centrica	Energy	April 2000	
		BSkyB / Singlepoint (Sky Phone)	Broadcasting	September 2000	
UK	Orange Plc	2G	Energis Plc (Energis Mobile)	Solutions provider	July 2000
			NTL (NTL Mobile)	Cable Operator	May 2001
	tba	tba	Tiscali	ISP	proposed



APPENDIX IV. STANDARDISATION

Five air interface modes have been adopted for 3G, each being standardised within the IMT-2000 “family” (WCDMA (TDD & FDD), CDMA200, DECT, and EDGE). Original goals for IMT-2000 included the ability to support data rates of 2 Mbps. All systems are able to achieve this in theory, with the differences arising for historical reasons, and the preferred methods to upgrade 2G systems in different regions around the world. It is hoped that true global roaming will still be achieved with devices able to switch between different modes.

Figure 8 shows possible evolution paths to 3G systems. In Europe, W-CDMA technology has been favoured as the upgrade from 2G, being standardised as UMTS.

Figure 7 Possible Evolution Paths to 3G

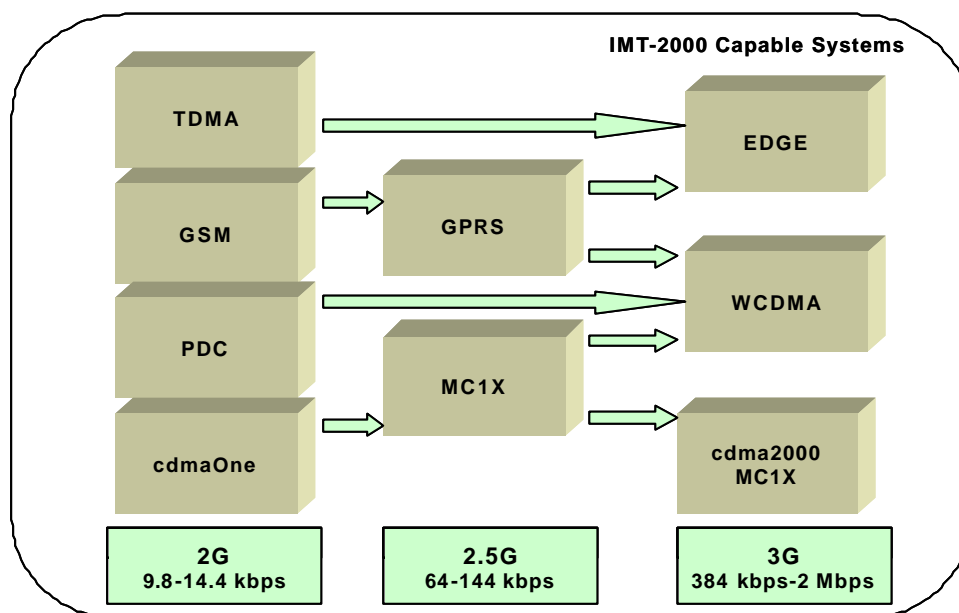

Significantly, industry has been at the forefront of standardisation activities for 3G. Partnership projects have been set up between supporting standards institutions and industry, following successful efforts to widen what were previously seen very much as national markets. Hence, industry has been keen to build on GSM’s successful implementation, and has made significant progress in tackling issues like Intellectual Property Rights.

International cooperation has facilitated:

- elimination of “patchwork” development efforts across the EU
- progress towards pan-European networks
- inter-working between different technologies at continental levels

For UMTS, standardisation work has taken place within the Third Generation Partnership Project (3GPP) (mirrored by the other partnership projects 3GPP2 and UWCW developing the other radio technologies), and the European Telecommunications Standards Institute



(ETSI). Apart from the other partnership projects, work has been carried out in conjunction with other standards bodies internationally (such as China Wireless Telecommunication Standards Organisation CWTS (China), TTC (Japan), TTA (Korea) and ANSI (USA)).

So far, two major releases of standards have been made – R(elease)99 and R4. R99 set out details for one of the WCDMA radio access network modes. These were expanded in the recent release. Release 5 will be a major landmark, as this will standardise IP-transport within the radio network, enabling full multimedia services and the integration of voice and data.

Following standardisation of systems, work is now being carried out to ensure interoperability of vendors' equipment (for example, ETSI in order to ensure inter-operator compatibility is complementary to other industry initiatives such as the Network Vendors Interoperability Testing Forum.

Other organisations also have a significant part to play in the development of 3G, especially as the distinction between voice and data networks becomes less clear. These include:

- (3)GSM Association, the leading body of GSM-based operators
- 3G Mobile Internet (3G.IP) facilitating development of future networks based on common core technologies
- International Telecommunications Union (ITU) Study Groups: Special Study Group (SSG) IMT2000 (in ITU-T) and Working Party WP8F (in ITU-R)
- Internet Engineering Task Force (IETF), becoming more involved as IP technology is introduced
- IPv6 Forum – encouraging implementation of IPv6 (but not carrying out standardisation activities)
- Mobile Wireless Internet Forum adoption of single mobile wireless and Internet architecture, independent of access technology
- UMTS Forum, which is made up of a cross section of industry players to examine standards, spectrum and any other issues falling within the development of future mobile services.



APPENDIX V. MOBILE TELECOMS REGULATION

V.1 Overview

The uncertainty surrounding the commercial success of post-2G mobile services means the nature and application of regulation assumes even more significance, with market players keen to have a degree of certainty in this area. In this respect, it is important to understand:

- current Member State regimes, including approaches to roaming
- approaches taken by non-EU regulators
- the key features of the proposed Common Regulatory Framework (in relation to access).

References to the Common Regulatory Framework, Authorisation and A&I Directives relate to the Common Positions agreed on 4 April 2001, and further agreements resulting from the examination of the recitals by the Group of Attachés on 23 April 2001.

V.2 Member State Regimes

Member State access regimes reflect their interpretation of the current Directives, and have been influenced by the different ways in, and speed at which, their markets have developed.

To date, requests for “access” to mobile networks have not been common, and NRAs’ concept of it is therefore broad. Whilst the “*special network access*” provision from the ONP Directives has been transposed in some Member States, it was not designed to be applied to mobile networks. *Interconnection*, however, has been a more controversial topic, leading to numerous disputes.

Uncertainty surrounding the future broadband multimedia environment has generally led to a strategy of “awaiting developments”.

The implications of access to mobile networks has been surveyed, to some degree, in at least seven Member States, either through explicit projects, or licence award consultations:

- *Denmark.* Roaming has been placed on the same footing as interconnection, such that all parties are obliged to negotiate agreements. This is one of the major reasons cited for the successful launch of a full MVNO there. The Danish market also has two MNO-MNO national roaming agreements in place, providing a form of infrastructure sharing
- *Germany.* The Service Provider concept is relatively well developed in the German market, with its two largest SPs having a greater market share than the smallest MNO. In its “Rules on the Award of Licences for UMTS/IMT-2000 Third Generation Mobile Communications”, the NRA made explicit that it foresaw its current regime continuing, with network access purely a matter of negotiation



- *Greece.* As part of the NRA's consultation on frequency allocation in mobile networks (2001), the possible types of players likely to be involved in the delivery of services in the future were established. Nevertheless, the current approach is one of awaiting developments on the 3G market
- *Ireland.* An extensive consultation was carried out in 2000 ("The Regulatory Framework for Access in the Mobile Market"), which included a survey of the range of entities likely to be present in the future mobile environment, and possible access issues. The consultation acknowledged that the new range of players would hopefully introduce further innovation and the promotion of convergent services. Whilst adopting a positive tone to such developments, the overall conclusion was to pursue commercial negotiation before invoking any regulatory steps, which would be on a *case-by-case* basis
- *Italy.* The NRA has issued a document analysing the various forms of market player. Whilst mandating MVNO-type access has been deferred until 2010, the development of Enhanced Service Providers (ESP) is being encouraged
- *The Netherlands.* A project relating to access to mobile networks is currently in progress and due to report later in 2001
- *Spain.* New players are to be introduced into the market in the form of SPs as a result of the NRA's consultation on competition in the mobile market
- *Sweden.* Since May 2000, MNOs have been obliged to sell spare capacity on networks to entities requesting it
- *UK.* OFTEL adopted a position on MVNOs in 1999, stating that regulatory intervention was not merited. A review of the mobile market is currently underway.

National roaming implemented purely by *commercial agreement* has been rare in the 2G environment. Denmark's situation is now relatively unique in setting national roaming on the same footing as interconnection. Such a step has to be explicit, since, according to the German NRA, interconnection is not strictly necessary for roaming to be accomplished, and therefore cannot be treated under the same regime as interconnection.

This distinction was also made clear in the European Parliament rapporteur's report on the A&ID:

"Roaming should not be seen as a form of access, given that, by way of an example, it has different connotations according to whether what is involved is enabling a user with a subscription to a foreign operator's network to use a mobile service in a given country (and vice-versa), or enabling operators entering the market to use the facilities of existing operators in a given country until such time as they have installed their own networks. National roaming was designed as an asymmetric, temporary and exceptional measure aimed at making it easier for new operators to come onto the market, whereas access to mobile networks is intended to solve long-term problems of bottlenecks in markets. Furthermore, treating access and roaming in the same way would inevitably lead to roaming services being provided on a cost-oriented pricing basis."



Most Member States have accepted that the absence of national roaming can put new entrants at a significant disadvantage. As a consequence, in the transfer to next-generation technologies, roaming has almost universally been mandated for new entrant licence holders, which do not already possess the means to deliver 2G services. All arrangements are subject to conditions, such as sunset periods, by which time new entrants are expected to have built out their own networks. Table 14 summarises Member States' current positions.

Table 15 Member State National Roaming

<i>Member State</i>	<i>NRA</i>	<i>3G-3G National Roaming</i>	<i>3G-2G National Roaming</i>	<i>Period</i>
Austria	TKC	No obligation	Mandatory, once 3G network has achieved 20% coverage	4 years
Belgium	IBPT	No obligation	No obligation, unless dispute arises between parties. 3G network must cover 20% of population	8 years
Denmark	TST	Mandatory	Mandatory	Indefinite
Finland	TAC	No obligation	Proposed Telecommunications Market Act may mandate roaming, but only after 5 months of failed commercial agreements and 20% of population coverage by 3G network is achieved	6 years /2 years, once 3G network reaches 80% coverage
France	ART	Allowed	Mandatory, subject to rollout and 6 year sunset	6 years
Germany	RegTP	No obligation	No obligation	N/A
Greece	EETT	3G-3G national roaming will be based on commercial negotiation	Mandatory. The EETT, in accordance with article 8 paragraph 3 of Act 2867/2000 issued a regulation setting the general framework for national roaming agreements (Decision of May 30 2001). MNOs must provide roaming by 31 December 2001	Unspecified
Ireland	ODTR	No obligation	Mandatory	5 years
Italy	Agcom	No obligation; Agcom must be notified within 30 days of commercial agreement conclusion	Mandatory	5 years
Luxembourg	ILT	No obligation.	No obligation (unless the mobile network operator has SMP)	N/A
Netherlands	OPTA	No obligation	No obligation (government rejected OPTA's decision)	N/A
Portugal	ICP	No obligation	Mandatory. Roaming conditions to be re-assessed 2 years after issuing of 3G licences	5 years
Spain	CMT	Not authorised	Mandatory, with sunset	3 years
Sweden	PTS	No obligation	Mandatory	7 years
UK	Oftel	No obligation	Mandatory. New entrant must first cover 20% of UK population (licence condition)	Until 2009

Sources: Study on national regulation of access to mobile networks, Cullen, March 2001; EuroStrategy Consultants, May 2001



V.3 Non-EU Approaches

V.3.1 Overview

EU markets are advanced in global terms, with the region's industry unique in facing *regulatory* harmonisation issues across so many state borders. As a result, non-EU countries have, on the whole, not yet had to deal with the range of problems being faced by EU NRAs.

Types of access other than interconnection, or requests for facilities more sophisticated than carrier selection, preselection or roaming, have not yet appeared on the agenda.

Whilst there has been a reliance on competition law in some countries, this has not necessarily had the desired result of producing a more open market.

V.3.2 New Zealand

The regulatory system in New Zealand is considerably different to that of the EU. There has, until 2001, been only very limited specific telecommunications regulation and no legal framework for interconnection (beyond general competition law). As such, there is no separate NRA body, other than the Commerce Commission, which administers general competition law.

Despite attempts to use "informal" regulation ("soft-law") to some degree in addition to the principle of relying on competition law, litigation has been an increasingly important method of trying to bring about dispute resolution. To date, this has relied on the interpretation and application of the Commerce Act. In one notable case, this led to the incumbent's position being supported in its dominant position in the negotiation of interconnection, contrary to most conventional thinking on the liberalisation of markets. Such a result can act as a significant disincentive for existing market players and for potential market entrants.

A new telecommunications act is now, in fact, being introduced to regulate specific services and resolve disputes, but will not be applied to mobile initially (although there is scope for mobile to be regulated if necessary). Incentives to invest in networks have been cited as a key concern, especially with a population of 4 million in a geographical area roughly the size of the UK. Hence the philosophy is one of "light touch", and for there to be market failure before introduction of any regulatory measures.

Currently two networks are in operation (Telecom NZ and Vodafone - Bell South), which have wholesale agreements with a limited number of service providers. Four new licenses have been established. Licensees are free to implement *any* technological solution.

V.3.3 Australia

In *Australia*, there are three major 2G operators, with two former service providers in the process of building out networks.

Since 1997, responsibility for telecommunications regulation has been shared between:



- the Australian Communications Authority (ACA), formed from the merger of the Spectrum Management Agency (SMA) and The Australian Telecommunications Authority (AUSTEL). The ACA is responsible for consumer and technical matters
- the Australian Competition and Consumer Commission (ACCC), taking over the responsibility for competition and economic affairs from Austel. This includes facilitating access to the networks of carriers.

The ACCC's powers include the ability to impose obligations (such as provision of non-discriminatory terms) once a service has been "declared". There has, so far, not been a great deal of pressure relating to access, apart from interconnection, for example, GSM termination. The appearance of new players, such as ESPs (for example, Virgin) may change this.

Previous investigations carried out by the ACCC have analysed the provision of long distance components of mobile calls by third parties (result:- no obligation), pricing principles for number portability, and the provision of inter-carrier (national) roaming.

Carrier preselection for national, fixed-to-mobile and international calls has been introduced.

Currently, a key regulatory issue is mobile termination rates, on which a report is being prepared.

V.3.4 Hong Kong

Six MNOs are present on the Hong Kong market, controlling a total of 11 networks (employing a range of technologies). Roaming to other operators is not mandated.

Four UMTS licences are to be allocated in 2001 via an auction. The NRA has proposed its own unique system, such that applicants bid a share of their revenues from *network usage* over the licence period that will act as payment for spectrum (this does not include revenues from applications or content). Licence cost is thus spread over the period of the licence. The reduction in number of operators immediately means that some will have to explore other strategies in order to supply 3G services, such as MVNO-type arrangements.

Access to networks is to be ensured by use of the "Open Network Policy", whose primary objective is to encourage more competition in the provision of content and applications in the 3G environment. In practice, this means an obligation on MNOs to make 30% of network capacity available to non-network owning organisations. These are envisaged as including not only traditional organisations (ranging from SPs to full MVNOs), but equally *the Small-Medium Enterprise (SME) sector*.

Whilst a "Consumer Council" exists in Hong Kong, there is no general competition law. Regulation of competition in the telecoms sector relies on the provisions contained in "Telecommunications Ordinance".

Market definition is carried out by the NRA for analysis purposes. Should disputes require the NRA to enforce interconnection, there is no appeals facility. Fines can be imposed on operators of \$1m or up to 10% of turnover (which may be appealed). The NRA anticipates having to enforce interconnection conditions in order to facilitate SMEs' access to networks.



This will be done via publication of an interconnection price (as at present), with MNOs publishing reference tariffs.

There is some sharing of facilities in hard-to-access areas, which are given the NRA's approval, but MNOs are generally expected to build-out their own networks.

V.3.5 USA

The US cellular market has developed from a system of regional licences. Expansion, and the trend towards issuing licences covering larger areas has led to several operators emerging at national level. National penetration is currently around 40%, but still includes analogue networks. No regulation of consumer prices, or "company profits" is in place, with reliance on competition law solutions.

The current system for interconnection charges (across all markets) is being revisited after the development of practices analogous to "tromboning" having led to market distortions. A report is due later in 2001. Other access to mobile networks, such as infrastructure sharing, is not a high regulatory priority and has not resulted in any major disputes yet.

Flexible use of spectrum is encouraged, with no (cellular) technological choices imposed. This is partly because consumers are generally blind to cellular technologies, and so any regulation should be used to facilitate the market, by removing barriers to its evolution (or conversely, step in when there is market failure).

Questions of spectrum allocation are more controversial, for example, the relative shares between satellite and cellular communications. The US has also experienced problems in the past regarding spectrum allocation methods where licensees have subsequently defaulted, raising questions of rights and ownership. Therefore, spectrum questions will be, key to future developments.

V.4 Common Regulatory Framework

V.4.1 Overview

The key elements relating to access and interconnection in the proposed regulatory programme reside in the CRFD and A&I Directives. As in the present framework, the access and interconnection regime:

- ensures "any-to-any" communications by compelling operators of communications networks to negotiate interconnection (Article 4 A&I, Article 4 Authorisation Directive)
- promotes the use of commercial negotiations to develop services before relying on regulatory intervention.

NRAs will be empowered to implement ex-ante regulation via the measures contained in the individual directives, chiefly:

- articles 8-13 of the A&ID



- articles 16, 25 and 27 of the Universal Service Directive (USD)

Number portability, for all networks, on cost-oriented terms is mandatory through the USD. Carrier selection and carrier pre-selection *may* be implemented for mobile networks, under article 25 of the USD, subject to market assessment.

Usually, the imposition of obligations will be triggered by SMP designation following an NRA's market analysis in accordance with articles 13 and 14 of the CRFD. To ensure use of uniform methodologies, the Commission has published "Draft Guidelines on market analysis and the calculation of significant market power" (COM(2001)175). This document describes the CRF's relationship with competition law and existing case law, and is itself based on other previously published guidelines. NRAs must also take into account the existing Liberalisation Directives.

In addition, under the responsibilities and powers described in Article 5 of the A&ID, NRAs are also able to:

- "... impose ... obligations on undertakings that control access to end-users, including in justified cases the obligation to interconnect their networks where this is not already the case"
- *intervene* [regarding access and interconnection] *at [their] own initiative where justified or ... at the request of either of the parties involved*" to achieve policy objectives (such as end-to-end connectivity, or the objectives set out in Article 7 of the CRFD) or resolve disputes.

Intervention in these cases does *not* rely on the designation of SMP.

V.4.2 SMP and Market Analysis

All market players have cited the lack of *legal certainty* in this area as a major concern. In particular, operators are worried that NRAs may (use their powers to) define markets too tightly, so that all players become subject to SMP designation, versus the implications of raising the threshold so that potentially only the market leader will be designated.

The existing framework of legislation defines Significant Market Power as having a 25% market share. The proposed framework has a definition aligned with the competition law concept of dominance, whereby:

"an undertaking shall be deemed to have significant market power if, either individually or jointly with others, it enjoys a position equivalent to dominance, i.e. a position of economic strength affording it the power to behave to an appreciable extent independently of competitors, customers and ultimately consumers."

Market analyses will be on the basis of product and service markets announced by the Commission, with NRAs responsible for carrying out analyses in individual Member States, or in conjunction with other NRAs, where the geographical aspects of markets are cross-border. In the product markets currently considered, access comprises *"all types of infrastructure that can be used for the provision of a given service."*



Whilst the Commission's guidelines suggest that volume or value sales can be used to measure *market share*, a range of other measures is also suggested for determining *market power*. Combined with the concepts of leverage of market power and joint dominance, it is apparent that market analyses will become increasingly complex.

V.4.3 NRA "Toolkit"

The USD states that where markets are not found to be sufficiently competitive, and obligations under the Access Directive have not achieved the desired results in solving a market problem, undertakings designated as having SMP may have obligations imposed at the retail level, including orienting their tariffs towards costs (Article 16). Indeed, carrier selection and pre-selection may be implemented for mobile networks under Article 25 of the USD, subject to market assessment.

Therefore, preference in the new regulatory model is at the wholesale access level where, in accordance with Article 8 of the A&ID (Imposition, amendment or withdrawal of obligations on SMP operators as a result of market failure on a relevant market), NRAs may "*impose the obligations as set out in articles 9-13 (transparency, non-discrimination, unbundled access, cost-orientation) as appropriate*". These measures have therefore been referred to as the NRA "Toolkit".

All steps taken are to be based on the nature of the problem identified, proportionate, and justified in relation to the policy objectives contained in the CRFD.

Any measures to be imposed on undertakings with SMP beyond those contained in the Directive are exceptional, and steps to impose such obligations must be authorised at Commission and Communications Committee levels.

The main features of measures imposed under articles 9-13 of the A&ID are summarised in Table 15.

Measures that may be used by NRAs in the proposed package are more explicit, but also designed to be more flexible since NRAs are allowed discretion in their application of the Directive. However, given that that interconnection disputes have been difficult to resolve in the present regime, with the added complexities of the required market analysis and consultation mechanism, and operators' vigorous opposition to cost-orientation, implementation of measures contained in the new framework will be far from simple.

Obligations concerning cost orientation and non-discriminatory access are particularly contentious. Central to their application is the objective of being "fair", but it is argued that:

- cost orientation needs to be flexible, since, if applied indiscriminately, smaller MNOs could suffer more than their larger counterparts
- non-discriminatory access harms incentives to the development of innovative solutions.



Table 16 NRA A&ID Toolkit

Article	Subject	Main elements relating to SMP-designated undertakings
9	Transparency	<p>Publication of information, such as accounting information, technical specifications, network characteristics, terms & conditions for supply & use, prices</p> <p>NRAs may specify format and level of information detail</p> <p>If article 10 applies, undertaking must publish a reference offer</p>
10	Non-discrimination	<p>Undertaking to apply equivalent conditions, and provide services and information under same conditions and of equivalent quality to their own services or those of subsidiaries and partners</p>
11	Accounting Separation	<p>Vertically integrated companies to publish wholesale and internal transfer prices, (inter alia) to prevent unfair cross subsidy and ensure non-discrimination, and accounting records to be provided</p>
12	Access and use of specific network facilities	<p>Requirements to:</p> <ul style="list-style-type: none"> • <i>negotiate in good faith</i> • not to withdraw access to facilities already granted • provide specified services on a wholesale basis for resale by third parties • grant open access to technical interfaces, protocols or other technologies that are indispensable for the interoperability of services or virtual network services • provide collocation or other forms of facility sharing, including duct, building or mast sharing • provide specified services needed to ensure interoperability of end-to-end services to users, including facilities for intelligent network services or roaming • provide access to operational support systems or similar software systems necessary to ensure fair competition in the provision of services • interconnect networks or network facilities <p>NRAs may attach to obligations conditions of fairness, reasonableness and timeliness</p> <p>When NRAs are considering whether to impose the above obligations, and in particular when assessing whether they would be proportionate to the objectives set out in Article 7, they shall take into account:</p> <ul style="list-style-type: none"> • the technical and economic viability of using or installing competing facilities in the light of the rate of market development, taking into account the nature and type of interconnection an access involved • the feasibility of providing the access proposed, in relation to the capacity available • the initial investment by the facility owner, bearing in mind the risks involved in making the investment • the need to safeguard competition in the long term • where appropriate, and relevant intellectual property rights • the provision of pan-European services
13	Price control & cost accounting	<p>Imposition of obligations relating to cost orientation, price controls and cost accounting relating to A&I</p> <p>Investment made by the undertaking is to be taken into account</p>



APPENDIX VI. CURRENT MNOs (AFTER 3G LICENCING PROCESS)

Member State	Network Operator (GSM)	Contest		Network Operator (UMTS)	Licences (EUR mln)	3G Operator Shareholders (Ownership Stake)	GPRS	
Austria	Connect Austria Gesellschaft fur Telekommunikation GmbH (ONE)	Auction	→	Connect Austria Gesellschaft fur Telekommunikation GmbH (ONE)	119.91	E.ON (60.7%), Telenor (21.1%), TDC (15%), Orange (17.45%)	✓	
	Max.mobil Telekommunikation Service GmbH		→	Max.mobil Telekommunikation Service GmbH	170.78	T-Mobile International AG (100%)	✓	
	Mobilkom Austria AG		→	Mobilkom Austria AG	171.51	Telekom Austria AG (100%)	✓	
	Tele.ring Telekom Service GmbH & Co KG		→	Mannesmann 3G	113.37	Vodafone Group Plc (99.22%)	✓	
					Hutchison 3G Austria GmbH	138.81	Hutchison 3G Europe (100%)	
					3G Mobile GmbH	117.73	Telefonica InterContinental SA (100%)	
Belgium	Proximus – Belgacom Mobile SA	Auction	→	Proximus – Belgacom Mobile AS	150.20	Belgacom SA (75%), Vodafone Group Plc (25%)	✓	
	KPN Orange Belgium NV/SA		→	KPN Orange Belgium NV	150.00	KPN Mobile NV (100%)		
	Mobistar SA		→	Mobistar NV	150.00	Orange SA (50.71%)	✓	
Denmark	Orange Denmark	Auction		4 licences to be awarded in Q3 2001		N.A.	✓	
	SONOFON A/S				✓			
	TDC Tele-Danmark Mobil A/S				✓			
	Telia A/S Danmark				✓			
Finland	Oy Radiolinja AB	Comparative Selection	→	Oy Radiolinja AB	0	Elisa Communications Group	✓	
	Sonera Oyj		→	Sonera Oyj	0	State, Pohjola Group, Sampo-Varma Group	✓	
	Telia Finland		→	Telia Finland	0	Telia Group (100%)	✓	
	Suomen 2G Oy		→	Suomen 3G Oy	0	Tele 2 (20%), local telecoms groups	✓	
France	Bouygues Telecom SA	Comparative Selection		2 additional licences to be awarded Q1 2002	4,954.59		✓	
	Orange France (Itineris)			Orange France (Itineris)	4,954.59	France Telecom SA (100%)	✓	
	Cegetel SFR Networks			Cegetel SFR Networks	4,954.59	Cegetel (80%), Vodafone Group (20%)	✓	



Member State	Network Operator (GSM)	Contest		Network Operator (UMTS)	Licences (EUR mln)	3G Operator Shareholders (Ownership Stake)	GPRS	
Germany	Mannesmann Mobilfunk GmbH (D2)	Auction	→	Mannesmann Mobilfunk	8,490.00	Vodafone Group Plc (100%)	✓	
	Deutsche Telekom MobilNet GmbH (T-mobil/D1)		→	T-mobil GmbH	8,478.34	Deutsche Telekom AG (100%)	✓	
	Viag Interkom GmbH & Co		→	Viag Interkom GmbH & Co	8,440.00	BT Wireless (100%)	✓	
	E-Plus Mobilfunk GmbH		→	E-Plus Mobilfunk GmbH	8,390.00	KPN Mobile NV (77.5%), Bellsouth Corporation (22.5%)	✓	
					Mobilcom Multimedia	8,370.00	Orange SA (28.5%)	
					Marabou GmbH (Group 3G)	8,408.71	Telefónica InterContinental SA, (57.2%) Sonera Holding BV (42.8%)	✓
Greece	CosmOTE Mobile Telecommunications SA	Auction		4 licences to be awarded in July 2001 (Invitation to Tender published on 1 June 2001)		N/A	✓	
	Panafon Vodafone SA				✓			
	STET Hellas SA				✓			
Ireland	Eircell-Vodafone Ltd	Comparative election		4 licences to be awarded (by January 2002 EC deadline)		N/A		
	Esat Digifone Ltd							
	Meteor Mobile Telecommunications Ltd							
Italy	Omnitel Vodafone SpA	Auction- Comparative election Hybrid	→	Omnitel-Vodafone SpA	2,243.11	Vodafone Group Plc (76.86%), Verizon (23.14%)	✓	
	Telecom Italia Mobile SpA		→	Telecom Italia Mobile SpA	2,214.71	Gruppo Telecom Italia SpA (55%)	✓	
	Wind Telecomunicazioni SpA		→	Wind Telecomunicazioni SpA	2,224.18	ENEL (56.5%), Orange SA (43.37%)	✓	
	Blu SpA			IPSE 2000 SpA	2,238.38	Telefonica InterContinental SA (45.6%), Sonera Holding BV (12.55%)		
					H3G SpA (formerly Andala)	2,224.18	Hutchison 3G Europe (78.3%), Tiscali (25.5%), CIRTEL	
Luxembourg	PTT Luxembourg SA	Comparative Selection		4 licences to be awarded in Q3 2001		N/A		
	Tango SA							
Netherlands	Ben Netherlands BV	Auction	→	3G Blue	394.97	Ben (50%), T-mobile International AG (50%)	✓	
	Dutchtone NV		→	Dutchtone NV	435.63	Orange SA (100%)	✓	
	KPN Mobile The Netherlands BV		→	KPN Mobile The Netherlands BV	711.07	KPN Telecom BV	✓	



Member State	Network Operator (GSM)	Contest		Network Operator (UMTS)	Licences (EUR mln)	3G Operator Shareholders (Ownership Stake)	GPRS
	Libertel Network BV		→	Libertel Network BV	713.80	Vodafone Group Plc (70%), State (22.5%), ING Bank (7.5%)	✓
	Telfort BV		→	Telfort BV	429.73	BT Wireless (100%)	✓
Portugal	Telecel Comunicacoes SA	ComparativeS election	→	Telecel Comunicacoes SA	99.76	Vodafone Group Plc, State	✓
	Telecomunicacoes Moveis Nacionais SA		→	Telecomunicacoes Moveis Nacionais SA	99.76	Portugal Telecom Group SA (100%)	✓
	Optimus Telecomunicacoes SA		→	Optimus Telecomunicacoes, SA	99.76	Orange SA (100%) ?	✓
Spain		ComparativeS election		OniWay	99.76	Telenor/Grapes (20%), EDP	
	Telefónica Móviles España SA		→	Telefónica Móviles España	0	Grupo Telefónica (92.15%)	✓
	Airtel Vodafone SA		→	Airtel-Vodafone SA	0	Vodafone Group Plc (91.6%)	✓
	Retevisión Móvil SA (Amena)		→	Retevisión Móvil SA (Amena)	0	Retevisión (40.1%), TIM (23.3%), Endesa (11.5%), Unión Fenosa (11.5%)	✓
Sweden		ComparativeS election		XFERA Móviles SA	0	Vivendi (29.5%), Fomento de Construcciones y Contratas (29.5%), ACS (20%), Sonera Holding BV (14.3%), Vodafone Group Plc (7%)	✓
	Europolitan-Vodafone AB		→	Europolitan-Vodafone AB	0.01	Vodafone Group Plc (71.1%), State (28.9%)	✓
	Comviq GSM AB			HI3G Access	0.01	Hutchison Whampoa (60%), Investor AB (40%)	
Sweden	Telia Mobile AB	ComparativeS election		Orange Sverige AB	0.01	Orange SA (51%), Bredbandsbolaget, Skanska, Schibsted	
				Tele2 AB	0.01	Netcom AB (100%)	✓
UK	BT Cellnet	Auction	→	BT3G	6,716.83	BT Wireless (100%)	✓
	One-2-One Personal Communications Ltd.		→	One-2-One Personal Communications Ltd	6,672.67	T-Mobile International A.G. (100%)	✓
	Orange Plc		→	Orange Plc	6,625.00	France Telecom SA (100%)	✓
	Vodafone UK		→	Vodafone UK	9,940.00	Vodafone Group Plc (100%)	✓
				TIW UMTS UK Ltd	7,307.83	Hutchison 3G UK Holdings Ltd	



APPENDIX VII. GPRS AND 3G (UMTS) SERVICE LAUNCH DATES

<i>Member State</i>	<i>Mobile Network Operator</i>	<i>GPRS Targeted Launch (Commercial)</i>	<i>GPRS Network Suppliers</i>	<i>3G Targeted Launch</i>
Austria	Max.mobil Telekommunikation Service GmbH	February 2001	Siemens	2 nd half 2002
	Mobilkom Austria AG	August 2000	Motorola-Cisco, Nortel	mid-2002
	Connect Austria Gesellschaft fur Telekommunikation Service GmbH (ONE)	March 2001	Nokia	mid-2001
	Tele.ring Telekom Service GmbH & co KG	January 2001	Alcatel	
Belgium	Proximus - Belgacom Mobile SA	Q2 2001	Nokia	Q3 2002
	Mobistar SA	March 2001	Nokia	September 2002
	KPN Orange Belgium NV/SA	2 nd half 2001		End of 2002
Denmark	Orange Denmark	April 2001	Nokia	<i>4 licences to be awarded in Q3 2001</i>
	SONOFON A/S	December 2000	Nokia	
	TDC Tele-Danmark Mobil A/S	January 2001	Ericsson, Nokia	
	Telia A/S Danmark	Q2 2001	Nokia	
Finland	Oy Radiolinja AB	Q2 2001	Nokia	<i>Not announced</i>
	Sonera Oyj	November 2000	Ericsson, Nokia	early 2002
	Telia Finland	September 2001	Nokia	Q4 2003
France	Bouygues Telecom SA	June 2001	Cisco, Ericsson, Nokia, Nortel	<i>2 licences to be awarded in May 2001</i>
	Orange France	June 2001	Alcatel, Ericsson, Motorola-Cisco-Nortel	
	SFR	June 2001	Alcatel, Nokia	
Germany	E-Plus Mobilfunk GmbH	March 2001	Nokia	Q4 2002
	Mannesmann Mobilfunk GmbH (D2)	January 2001	Ericsson, Siemens	2002
	Marabou GmbH (Group 3G)			Q3 2002



Member State	Mobile Network Operator	GPRS Targeted Launch (Commercial)	GPRS Network Suppliers	3G Targeted Launch
	T-Mobil GmbH	June 2001	Alcatel, Lucent, Motorola, Cisco	Q4 2002
	VIAG Interkom GmbH & Co	January 2001	Nokia	Q1 2003
Greece	CosmOTE Mobile Telecommunications SA	January 2001	Nokia	4 licences to be awarded in July 2001
	Panafon-Vodafone SA	Q2 2001	Ericsson	
	STET Hellas SA	Q2 2001	Ericsson	
Italy	Blu SpA	December 2000	Nokia	No 3G licence
	Omnitel-Vodafone SpA	November 2000	Nokia	2002
	Telecom Italia Mobile SpA	2 nd half 2001	Ericsson, Siemens	2002
	Wind Telecomunicazioni SpA	Q1 2001	Alcatel, Ericsson, Siemens	2002
	IPSE 2000 SpA	not offered	N/A	Q3 2001
Netherlands	Ben Netherlands BV/3G Blue	Q3 2001	Nokia	
	Dutchtone NV	First half 2001	Nokia	
	KPN Mobile The Netherlands BV	December 2000	Nokia	Q4 2002
	Libertel Netwerk BV	Q2 2001	Cisco, Ericsson	Q4 2002
	Telfort BV	2001	Ericsson	
Portugall	OniWay	Not offered	N/A	November 2001
	Optimus Telecomunicacoes SA	Q1 2001	Ericsson, Motorola, Nokia	mid-2002
	Telecel Comunicacoes SA	March 2001	Ericsson	mid-2002
	Telecomunicacoes Moveis Nacionais SA	November 2000	Alcatel	mid-2002
Spain	Airtel-Vodafone SA	Q1 2001	Ericsson, Siemens	August 2001
	Retevisión Movil SA (Amena)	1 st half 2001	Ericsson	August 2001
	Telefónica Móviles SA	January 2001	Motorola-Cisco, Nokia, Nortel	August 2001
Sweden	Europolitan-Vodafone AB	December 2000	Nokia	2003



<i>Member State</i>	<i>Mobile Network Operator</i>	<i>GPRS Targeted Launch (Commercial)</i>	<i>GPRS Network Suppliers</i>	<i>3G Targeted Launch</i>
	Tele 2AB	Q1 2001	Motorola-Cisco, Siemens	2003
	Telia Mobile AB	September 2001	Ericsson	2003
UK	BT Cellnet/BT 3G	May 2001	Motorola-Cisco	Q3 2001
	One-2-One Personal Communications Ltd	Q1 2001	Ericsson, Nortel	Q4 2002
	Orange Plc	Q2 2001	Ericsson	
	Hutchison UK			mid-2002
	Vodafone UK	Q2 2001	Ericsson	Q3 2002