

ANNEX I
SUMMARY OF PRODUCT CHARACTERISTICS

1. NAME OF THE MEDICINAL PRODUCT

Bydureon 2 mg powder and solvent for prolonged-release suspension for injection

2. QUALITATIVE AND QUANTITATIVE COMPOSITION

Each vial contains 2 mg of exenatide.

For the full list of excipients, see section 6.1.

3. PHARMACEUTICAL FORM

Powder and solvent for prolonged-release suspension for injection.

Powder: white to off-white powder.

Solvent: clear, colourless to pale yellow to pale brown solution.

4. CLINICAL PARTICULARS

4.1 Therapeutic indications

Bydureon is indicated in adults 18 years and older with type 2 diabetes mellitus to improve glycaemic control in combination with other glucose-lowering medicinal products including basal insulin, when the therapy in use, together with diet and exercise, does not provide adequate glycaemic control (see section 4.4, 4.5 and 5.1 for available data on different combinations).

4.2 Posology and method of administration

Posology

The recommended dose is 2 mg exenatide once weekly.

Patients switching from immediate-release (Byetta) to prolonged-release (Bydureon or Bydureon BCise) exenatide, may experience transient elevations in blood glucose concentrations, which generally improve within the first two weeks after initiation of therapy. Patients switching between the prolonged-release exenatide products (Bydureon or Bydureon BCise) may do so, with no expected relevant effect on blood glucose concentrations.

When prolonged-release exenatide is added to existing metformin and/or thiazolidinedione therapy, the current dose of metformin and/or thiazolidinedione can be continued. When added to sulphonylurea therapy, a reduction in the dose of sulphonylurea should be considered to reduce the risk of hypoglycaemia (see section 4.4).

Prolonged-release exenatide should be administered once a week on the same day each week. The day of weekly administration can be changed if necessary as long as the last dose was administered at least three days before. Prolonged-release exenatide can be administered at any time of day, with or without meals.

If a dose is missed, it should be administered as soon as practical, provided the next regularly scheduled dose is due in 3 days or more. Thereafter, patients can resume their usual once weekly dosing schedule.

If a dose is missed and the next regularly scheduled dose is due 1 or 2 days later, the patient should not administer the missed dose, but instead resume prolonged-release exenatide on the next regularly scheduled dosing day.

The use of prolonged-release exenatide does not require additional self-monitoring. Blood glucose self-monitoring may be necessary to adjust the dose of sulphonylurea.

If a different glucose-lowering treatment is started after the discontinuation of prolonged-release exenatide, consideration should be given to the prolonged release of the medicinal product (see section 5.2).

Special populations

Elderly

No dose adjustment is required based on age. However, as renal function generally declines with age, consideration should be given to the patient's renal function (see *Renal impairment*). The clinical experience in patients > 75 years is very limited (see section 5.2).

Renal impairment

No dose adjustment is necessary for patients with mild renal impairment (creatinine clearance 50 to 80 ml/min). Clinical experience in patients with moderate renal impairment (creatinine clearance 30 to 50 ml/min) is very limited (see section 5.2). Prolonged-release exenatide is not recommended in these patients.

Prolonged-release exenatide is not recommended for use in patients with end-stage renal disease or severe renal impairment (creatinine clearance < 30 ml/min) (see section 4.4).

Hepatic impairment

No dose adjustment is necessary for patients with hepatic impairment (see section 5.2).

Paediatric population

The safety and efficacy of prolonged-release exenatide in children and adolescents aged under 18 years have not yet been established. Currently available data are described in section 5.2 but no recommendation on a posology can be made.

Method of administration

Subcutaneous use

Prolonged-release exenatide is for self-administration by the patient. Each kit should be used by one person only and is for single use.

Prior to initiation of prolonged-release exenatide, it is strongly recommended that patients and caregivers be trained by their healthcare professional. The "Instructions for the User", provided in the carton, must be followed carefully.

Each dose should be administered in the abdomen, thigh, or the back of the upper arm as a subcutaneous injection immediately after suspension of the powder in the solvent.

When used with insulin, prolonged-release exenatide and insulin must be administered as two separate injections.

For instructions on the suspension of the medicinal product before administration, see section 6.6 and the "Instructions for the User".

4.3 Contraindications

Hypersensitivity to the active substance or to any of the excipients listed in section 6.1.

4.4 Special warnings and precautions for use

Prolonged-release exenatide should not be used in patients with type 1 diabetes mellitus or for the treatment of diabetic ketoacidosis.

Prolonged-release exenatide must not be administered by intravenous or intramuscular injection.

Renal impairment

In patients with end-stage renal disease receiving dialysis, single doses of immediate-release exenatide increased frequency and severity of gastrointestinal adverse reactions; therefore, prolonged-release exenatide is not recommended for use in patients with end-stage renal disease or severe renal impairment (creatinine clearance < 30 ml/min). The clinical experience in patients with moderate renal impairment is very limited and the use of prolonged-release exenatide is not recommended.

There have been uncommon events of altered renal function with exenatide, including increased serum creatinine, renal impairment, worsened chronic renal failure and acute renal failure, sometimes requiring haemodialysis. Some of these events occurred in patients experiencing events that may affect hydration, including nausea, vomiting, and/or diarrhoea and/or receiving medicinal products known to affect renal function/hydration status. Concomitant medicinal products included angiotensin converting enzymes inhibitors, angiotensin-II antagonists, non-steroidal anti-inflammatory medicinal products and diuretics. Reversibility of altered renal function has been observed with supportive treatment and discontinuation of potentially causative medicinal products, including exenatide.

Severe gastrointestinal disease

Prolonged-release exenatide has not been studied in patients with severe gastrointestinal disease, including gastroparesis. Its use is commonly associated with gastrointestinal adverse reactions, including nausea, vomiting, and diarrhoea. Therefore, the use of prolonged-release exenatide is not recommended in patients with severe gastrointestinal disease.

Acute pancreatitis

Use of GLP-1 receptor agonists has been associated with a risk of developing acute pancreatitis. In clinical studies of prolonged-release exenatide, acute pancreatitis occurred in 0.3% of patients. There have been spontaneously reported events of acute pancreatitis with prolonged-release exenatide. Resolution of pancreatitis has been observed with supportive treatment, but very rare cases of necrotising or haemorrhagic pancreatitis and/or death have been reported. Patients should be informed of the characteristic symptom of acute pancreatitis: persistent, severe abdominal pain. If pancreatitis is suspected, prolonged-release exenatide should be discontinued; if acute pancreatitis is confirmed, prolonged-release exenatide should not be restarted. Caution should be exercised in patients with a history of pancreatitis.

Concomitant medicinal products

The concurrent use of prolonged-release exenatide with D-phenylalanine derivatives (meglitinides), alpha-glucosidase inhibitors, dipeptidyl peptidase-4 inhibitors or other GLP-1 receptor agonists has not been studied. The concurrent use of prolonged-release and immediate-release exenatide has not been studied and is not recommended.

Interaction with warfarin

There have been spontaneously reported cases of increased INR (International Normalised Ratio), sometimes associated with bleeding, with concomitant use of warfarin and exenatide (see section 4.5).

Hypoglycaemia

The risk of hypoglycaemia was increased when prolonged-release exenatide was used in combination with a sulphonylurea in clinical studies. Furthermore, in the clinical studies, patients on a sulphonylurea combination, with mild renal impairment had an increased incidence of hypoglycaemia compared to patients with normal renal function. To reduce the risk of hypoglycaemia associated with the use of a sulphonylurea, reduction in the dose of sulphonylurea should be considered.

Rapid weight loss

Rapid weight loss at a rate of >1.5 kg per week has been reported in patients treated with exenatide. Weight loss of this rate may have harmful consequences. Patients with rapid weight loss should be monitored for signs and symptoms of cholelithiasis.

Discontinuation of treatment

After discontinuation, the effect of prolonged-release exenatide may continue as plasma levels of exenatide decline over 10 weeks. Choice of other medicinal products and dose selection should be considered accordingly, as adverse reactions may continue and efficacy may, at least partly, persist until exenatide levels decline.

Excipients

Sodium content: This medicinal product contains less than 1 mmol sodium (23 mg) per dose, i.e. essentially “sodium-free”.

4.5 Interaction with other medicinal products and other forms of interaction

Sulphonylureas

The dose of a sulphonylurea may require adjustment due to the increased risk of hypoglycaemia associated with sulphonylurea therapy (see sections 4.2 and 4.4).

Gastric emptying

The results of a study using paracetamol as a marker of gastric emptying suggest that the effect of prolonged-release exenatide to slow gastric emptying is minor and not expected to cause clinically significant reductions in the rate and extent of absorption of concomitantly administered oral medicinal products. Therefore, no dose adjustments for medicinal products sensitive to delayed gastric emptying are required.

When 1,000 mg paracetamol tablets were administered, either with or without a meal, following 14 weeks of prolonged-release exenatide therapy, no significant changes in paracetamol AUC were observed compared to the control period. Paracetamol C_{max} decreased by 16 % (fasting) and 5 % (fed) and t_{max} was increased from approximately 1 hour in the control period to 1.4 hours (fasting) and 1.3 hours (fed).

The following interaction studies have been conducted using 10 mcg immediate-release exenatide but not prolonged-release exenatide:

Warfarin

A delay in t_{max} of about 2 h was observed when warfarin was administered 35 min after immediate-release exenatide. No clinically relevant effects on C_{max} or AUC were observed. Increased INR has been spontaneously reported during concomitant use of warfarin and prolonged-release exenatide. INR should be monitored during initiation of prolonged-release exenatide therapy in patients on warfarin and/or coumarin derivatives (see sections 4.4 and 4.8).

Hydroxy methyl glutaryl coenzyme A reductase inhibitors

Lovastatin AUC and C_{max} were decreased approximately 40 % and 28 %, respectively, and t_{max} was delayed about 4 h when immediate-release exenatide was administered concomitantly with a single dose of lovastatin (40 mg) compared with lovastatin administered alone. In 30-week placebo-controlled clinical studies with immediate-release exenatide, concomitant use of exenatide and HMG CoA reductase inhibitors was not associated with consistent changes in lipid profiles (see section 5.1). No predetermined dose adjustment is required; however, lipid profiles should be monitored as appropriate.

Digoxin and lisinopril

In interaction studies of the effect of immediate-release exenatide on digoxin and lisinopril there were no clinically relevant effects on C_{max} or AUC, however, a delay in t_{max} of about 2 h was observed.

Ethinyl estradiol and levonorgestrel

Administration of a combination oral contraceptive (30 mcg ethinyl estradiol plus 150 mcg levonorgestrel) one hour before immediate-release exenatide did not alter the AUC, C_{max} or C_{min} of either ethinyl estradiol or levonorgestrel. Administration of the oral contraceptive 35 minutes after

exenatide did not affect AUC but resulted in a reduction of the C_{max} of ethinyl estradiol by 45 %, and C_{max} of levonorgestrel by 27-41 %, and a delay in t_{max} by 2-4 h due to delayed gastric emptying. The reduction in C_{max} is of limited clinical relevance and no adjustment of dosing of oral contraceptives is required.

Paediatric population

Interaction studies with exenatide have only been performed in adults.

4.6 Fertility, pregnancy and lactation

Women of childbearing potential

Due to the long washout period of prolonged-release exenatide, women of childbearing potential should use contraception during treatment with prolonged-release exenatide. This medicinal product should be discontinued at least 3 months before a planned pregnancy.

Pregnancy

There are no adequate data from the use of prolonged-release exenatide in pregnant women. Studies in animals have shown reproductive toxicity (see section 5.3). The potential risk for humans is unknown. Prolonged-release exenatide should not be used during pregnancy and the use of insulin is recommended.

Breast-feeding

It is unknown whether exenatide is excreted in human milk. Prolonged-release exenatide should not be used during breast-feeding.

Fertility

No fertility studies in humans have been conducted.

4.7 Effects on ability to drive and use machines

Prolonged-release exenatide has minor influence on the ability to drive and use machines. When prolonged-release exenatide is used in combination with a sulphonylurea, patients should be advised to take precautions to avoid hypoglycaemia while driving and using machines.

4.8 Undesirable effects

Summary of the safety profile

The most frequent adverse reactions were mainly gastrointestinal related (nausea which was the most frequent reaction and associated with the initiation of treatment and decreased over time, and diarrhoea). In addition, injection site reactions (pruritus, nodules, erythema), hypoglycaemia (with a sulphonylurea), and headache occurred. Most adverse reactions associated with prolonged-release exenatide were mild to moderate in intensity.

Tabulated list of adverse reactions

The frequency of adverse reactions of prolonged-release exenatide identified from clinical studies and spontaneous reports (not observed in clinical studies, frequency not known) are summarised in Table 1 below.

In the prolonged-release exenatide clinical studies, background therapies included diet and exercise, metformin, a sulphonylurea, a thiazolidinedione, a combination of oral glucose-lowering medicinal products or a basal insulin.

The reactions are listed below as MedDRA preferred term by system organ class and absolute frequency. Frequencies are defined as: very common ($\geq 1/10$), common ($\geq 1/100$ to $< 1/10$), uncommon ($\geq 1/1,000$ to $< 1/100$), rare ($\geq 1/10,000$ to $< 1/1,000$) very rare ($< 1/10,000$) and not known (cannot be estimated from the available data).

Table 1: Adverse reactions of prolonged-release exenatide identified from clinical studies and spontaneous reports

System organ class /adverse reaction terms	Frequency of occurrence					
	Very common	Common	Uncommon	Rare	Very rare	Not known
Immune system disorders						
Anaphylactic reaction				X ¹		
Metabolism and nutrition disorders						
Hypoglycaemia (with a sulphonylurea)	X ¹					
Hypoglycaemia (with insulin)		X ^{2,3}				
Decreased appetite		X ¹				
Dehydration			X ¹			
Nervous system disorders						
Headache		X ¹				
Dizziness		X ¹				
Dysgeusia			X ¹			
Somnolence			X ¹			
Gastrointestinal disorders						
Intestinal obstruction			X ¹			
Acute pancreatitis (see section 4.4)			X ¹			
Nausea	X ¹					
Vomiting		X ¹				
Diarrhoea	X ¹					
Dyspepsia		X ¹				
Abdominal pain		X ¹				
Gastroesophageal reflux disease		X ¹				
Abdominal distension		X ¹				
Eructation			X ¹			
Constipation		X ¹				
Flatulence		X ¹				
Skin and subcutaneous tissue disorders						
Macular and papular rash						X ⁴
Pruritus, and/ or urticaria		X ¹				
Angioneurotic oedema						X ⁴
Injection site abscesses and cellulitis						X ⁴
Hyperhidrosis			X ¹			
Alopecia			X ¹			
Renal and urinary disorders						
Altered renal function, including acute renal failure, worsened chronic renal failure, renal impairment, increased serum			X ¹			

System organ class /adverse reaction terms	Frequency of occurrence					
	Very common	Common	Uncommon	Rare	Very rare	Not known
creatinine (see section 4.4).						
General disorders and administration site conditions						
Injection site pruritus		X ¹				
Fatigue		X ¹				
Injection site erythema		X ¹				
Injection site rash			X ¹			
Asthenia		X ¹				
Feeling jittery				X ¹		
Investigations						
International normalised ratio increased (see section 4.4)						X ⁴

¹ Rate based on twelve prolonged-release exenatide completed long-term efficacy and safety studies n = 2868 total (patients on sulphonylurea n = 1002).

² Based on hypoglycaemic events that 1. Result in loss of consciousness, seizure, or coma which resolves after administration of glucagon or glucose OR 2. Require third-party assistance to resolve because of impairment in consciousness or behaviour and has glucose value of <54 mg/dL (3 mmol/L) OR 3. Result in symptoms consistent with hypoglycaemia with a concomitant glucose <54 mg/dL (3 mmol/L) prior to treatment.

³ Frequency reported from the 28-week controlled treatment period of the prolonged-release exenatide as add-on to insulin glargine study (N=232).

⁴ Rate based on prolonged-release exenatide spontaneous reports data (unknown denominator).

Description of selected adverse reactions

Hypoglycaemia

The incidence of hypoglycaemia was increased when prolonged-release exenatide was used in combination with a sulphonylurea (24.0 % versus 5.4 %) (see section 4.4). To reduce the risk of hypoglycaemia associated with the use of a sulphonylurea, reduction in the dose of sulphonylurea may be considered (see sections 4.2 and 4.4).

Prolonged-release exenatide was associated with a significantly lower incidence of episodes of hypoglycaemia than basal insulin in patients also receiving metformin therapy (3 % versus 19 %) and in patients also receiving metformin plus sulphonylurea therapy (20 % versus 42 %).

Across 12 studies of prolonged-release exenatide most episodes (99.9 % n = 649) of hypoglycaemia were minor, and resolved with oral administration of carbohydrate. One patient was reported with major hypoglycaemia since he had a low blood glucose value (2.2 mmol/l) and requested assistance with oral carbohydrate treatment which resolved the event.

When prolonged-release exenatide was added to basal insulin, no initial dose adjustment of insulin was required. Prolonged-release exenatide in combination with basal insulin showed no clinically significant differences in the incidence of hypoglycaemic episodes compared to insulin. There were no episodes of major hypoglycaemia in the prolonged-release exenatide with insulin group.

Nausea

The most frequently reported adverse reaction was nausea. In patients treated with prolonged-release exenatide, generally 20 % reported at least one episode of nausea compared to 34 % of

immediate-release exenatide patients. Most episodes of nausea were mild to moderate. With continued therapy, the frequency decreased in most patients who initially experienced nausea.

The incidence of withdrawal due to adverse events during the 30-week controlled study was 6 % for prolonged-release exenatide treated patients, 5 % for immediate-release exenatide treated patients. The most common adverse events leading to withdrawal in either treatment group were nausea and vomiting. Withdrawal due to nausea or vomiting each occurred in < 1 % for prolonged-release exenatide treated patients and 1 % for immediate-release exenatide treated patients.

Injection site reactions

Injection site reactions were observed more frequently in prolonged-release exenatide treated patients versus comparator-treated patients (16 % versus range of 2-7 %) during the 6-month controlled phase of studies. These injection site reactions were generally mild and usually did not lead to withdrawal from studies. Patients may be treated to relieve symptoms, while continuing treatment. Subsequent injections should use a different site of injection each week. In postmarketing experiences, cases with injection site abscesses and cellulitis have been reported.

Small subcutaneous injection site nodules were observed very frequently in clinical studies, consistent with the known properties of poly (D,L-lactide co-glycolide) polymer microsphere formulations. Most individual nodules were asymptomatic, did not interfere with study participation and resolved over 4 to 8 weeks.

Immunogenicity

Consistent with the potentially immunogenic properties of protein and peptide pharmaceuticals, patients may develop antibodies to exenatide following treatment with prolonged-release exenatide. In most patients who develop antibodies, antibody titres diminish over time.

The presence of antibodies (high or low titres) is not predictive of glycaemic control for an individual patient.

In clinical studies of prolonged-release exenatide, approximately 45 % of patients had low titre antibodies to exenatide at study endpoint. Overall, the percentage of antibody positive patients was consistent across clinical studies. Overall, the level of glycaemic control (HbA_{1c}) was comparable to that observed in those without antibody titres. On average in the phase 3 studies, 12 % of the patients had higher titre antibodies. In a proportion of these the glycaemic response to prolonged-release exenatide was absent at the end of the controlled period of studies; 2.6 % of patients showed no glucose improvement with higher titre antibodies whereas 1.6 % showed no improvement while antibody negative.

Patients who developed antibodies to exenatide tend to have more injection site reactions (for example: redness of skin and itching), but otherwise similar rates and types of adverse events as those with no antibodies to exenatide.

For prolonged-release exenatide treated patients, the incidence of potentially immunogenic injection site reactions (most commonly pruritus with or without erythema) during the 30-week and the two 26-week studies was 9 %. These reactions were less commonly observed in antibody-negative patients (4 %) compared with antibody-positive patients (13 %), with a greater incidence in those with higher titre antibodies.

Examination of antibody-positive specimens revealed no significant cross-reactivity with similar endogenous peptides (glucagon or GLP-1).

Rapid weight loss

In a 30-week study, approximately 3 % (n = 4/148) of prolonged-release exenatide treated patients experienced at least one time period of rapid weight loss (recorded body weight loss between two consecutive study visits of greater than 1.5 kg/week).

Increased heart rate

A mean increase in heart rate (HR) of 2.6 beats per minute (bpm) from baseline (74 bpm) was observed in pooled prolonged-release exenatide clinical studies. Fifteen percent of prolonged-release exenatide treated patients had mean increases in HR of ≥ 10 bpm; approximately 5 % to 10 % of subjects within the other treatment groups had mean increases in HR of ≥ 10 bpm.

Reporting of suspected adverse reactions

Reporting suspected adverse reactions after authorisation of the medicinal product is important. It allows continued monitoring of the benefit/risk balance of the medicinal product. Healthcare professionals are asked to report any suspected adverse reactions via the national reporting system listed in [Appendix V](#).

4.9 Overdose

Effects of overdoses with exenatide (based on immediate-release exenatide clinical studies) included severe nausea, severe vomiting and rapidly declining blood glucose concentrations. In the event of overdose, appropriate supportive treatment should be initiated according to the patient's clinical signs and symptoms.

5. PHARMACOLOGICAL PROPERTIES

5.1 Pharmacodynamic properties

Pharmacotherapeutic group: Drugs used in diabetes, glucagon-like peptide-1 (GLP-1) analogues, ATC code: A10BJ01.

Mechanism of action

Exenatide is a glucagon-like peptide-1 (GLP-1) receptor agonist that exhibits several antihyperglycaemic actions of glucagon-like peptide-1 (GLP-1). The amino acid sequence of exenatide partially overlaps that of human GLP-1. Exenatide has been shown to bind to and activate the known human GLP-1 receptor *in vitro*, its mechanism of action mediated by cyclic AMP and/or other intracellular signalling pathways.

Exenatide increases, on a glucose-dependent basis, the secretion of insulin from pancreatic beta cells. As blood glucose concentrations decrease, insulin secretion subsides. When exenatide was used in combination with metformin and/or a thiazolidinedione, no increase in the incidence of hypoglycaemia was observed over that of placebo in combination with metformin and/or a thiazolidinedione which may be due to this glucose-dependent insulinotropic mechanism (see section 4.4).

Exenatide suppresses glucagon secretion which is known to be inappropriately elevated in patients with type 2 diabetes. Lower glucagon concentrations lead to decreased hepatic glucose output. However, exenatide does not impair the normal glucagon response and other hormone responses to hypoglycaemia.

Exenatide slows gastric emptying, thereby reducing the rate at which meal-derived glucose appears in the circulation.

Administration of exenatide has been shown to reduce food intake, due to decreased appetite and increased satiety.

Pharmacodynamic effects

Exenatide improves glycaemic control through the sustained effects of lowering both postprandial and fasting glucose concentrations in patients with type 2 diabetes. Unlike native GLP-1, prolonged-release exenatide has a pharmacokinetic and pharmacodynamic profile in humans suitable for once weekly administration.

A pharmacodynamic study with exenatide demonstrated in patients with type 2 diabetes (n = 13) a restoration of first phase insulin secretion and improved second phase insulin secretion in response to an intravenous bolus of glucose.

Clinical efficacy and safety

The results of long-term clinical studies of prolonged-release exenatide are presented below; these studies comprised 1356 subjects treated with prolonged-release exenatide, 52 % men and 48 % women; 230 subjects (17 %) were ≥ 65 years of age.

Glycaemic control

In two studies prolonged-release exenatide 2 mg once weekly has been compared to immediate-release exenatide 5 mcg given twice daily for 4 weeks followed by immediate-release exenatide 10 mcg given twice daily. One study was of 24 weeks in duration (n = 252) and the other of 30 weeks (n = 295) followed by an open labelled extension where all patients were treated with prolonged-release exenatide 2 mg once weekly, for a further 7 years (n = 258). In both studies, decreases in HbA_{1c} were evident in both treatment groups as early as the first post-treatment HbA_{1c} measurement (weeks 4 or 6).

Prolonged-release exenatide resulted in a statistically significant reduction in HbA_{1c} compared to patients receiving immediate-release exenatide (Table 2).

A clinically relevant effect of prolonged-release exenatide and immediate-release exenatide treated subjects was observed on HbA_{1c}, regardless of the background anti-diabetic therapy in both studies.

Clinically and statistically significantly more subjects on prolonged-release compared to immediate-release exenatide patients achieved an HbA_{1c} reduction of $\leq 7\%$ or $< 7\%$ in the two studies (p < 0.05 and p \leq 0.0001 respectively).

Both prolonged-release and immediate-release exenatide patients achieved a reduction in weight compared to baseline, although the difference between the two treatment arms was not significant.

In the uncontrolled study extension, evaluable patients who switched from immediate release to prolonged-release exenatide at week 30 (n = 121), achieved the same improvement in HbA_{1c} of -2.0 % at week 52 compared to baseline as patients treated with prolonged-release exenatide.

For all patients completing the uncontrolled study extension of 7 years (n = 122 of 258 patients included in the extension phase), HbA_{1c} gradually increased over time from week 52 onwards, but was still reduced compared to baseline after 7 years (-1.5 %). Weight loss was sustained over 7 years in these patients.

Table 2: Results of two studies of prolonged-release versus immediate-release exenatide in combination with diet and exercise alone, metformin and/or sulphonylurea and metformin and/or thiazolidinedione (intent to treat patients)

24-Week Study	Prolonged-release exenatide 2 mg	Immediate-release exenatide 10 mcg twice daily
N	129	123
Mean HbA_{1c} (%)		
Baseline	8.5	8.4
Change from baseline (\pm SE)	-1.6 (\pm 0.1)**	-0.9 (\pm 0.1)
Mean difference change from baseline between treatments (95 % CI)	-0.67 (-0.94, -0.39)**	
Patients (%) achieving HbA_{1c} < 7 %	58	30
Change in fasting plasma glucose (mmol/l) (\pm SE)	-1.4 (\pm 0.2)	-0.3 (\pm 0.2)

24-Week Study	Prolonged-release exenatide 2 mg	Immediate-release exenatide 10 mcg twice daily
Mean body weight (kg)		
Baseline	97	94
Change from baseline (\pm SE)	-2.3 (\pm 0.4)	-1.4 (\pm 0.4)
Mean difference change from baseline between treatments (95 % CI)	-0.95 (-1.91, 0.01)	
30-Week Study		
N	148	147
Mean HbA_{1c} (%)		
Baseline	8.3	8.3
Change from baseline (\pm SE)	-1.9 (\pm 0.1)*	-1.5 (\pm 0.1)
Mean difference change from baseline between treatments (95 % CI)	-0.33 (-0.54, -0.12)*	
Patients (%) achieving HbA_{1c} \leq 7 %	73	57
Change in fasting plasma glucose (mmol/l) (\pm SE)	-2.3 (\pm 0.2)	-1.4 (\pm 0.2)
Mean body weight (kg)		
Baseline	102	102
Change from baseline (\pm SE)	-3.7 (\pm 0.5)	-3.6 (\pm 0.5)
Mean difference change from baseline between treatments (95 % CI)	-0.08 (-1.29, 1.12)	

SE = standard error, CI = confidence interval, * $p < 0.05$, ** $p < 0.0001$

A study of 26-week duration has been conducted, in which prolonged-release exenatide 2 mg is compared to insulin glargine once daily. Compared with insulin glargine treatment, prolonged-release exenatide demonstrated a superior change in HbA_{1c}, significantly lowered mean body weight and was associated with fewer hypoglycaemic events (Table 3).

Table 3: Results of one 26-week study of prolonged-release exenatide versus insulin glargine in combination with metformin alone or metformin and sulphonylurea (intent to treat patients)

	Prolonged-release exenatide 2 mg	Insulin glargine¹
N	233	223
Mean HbA_{1c} (%)		
Baseline	8.3	8.3
Change from baseline (± SE)	-1.5 (± 0.1)*	-1.3 (± 0.1)*
Mean difference change from baseline between treatments (95 % CI)	-0.16 (-0.29, -0.03)*	
Patients (%) achieving HbA_{1c} ≤ 7 %	62	54
Change in fasting serum glucose (mmol/l) (± SE)	-2.1 (± 0.2)	-2.8 (± 0.2)
Mean body weight (kg)		
Baseline	91	91
Change from baseline (± SE)	-2.6 (± 0.2)	+1.4 (± 0.2)
Mean difference change from baseline between treatments (95 % CI)	-4.05 (-4.57, -3.52)*	

SE = standard error, CI = confidence interval, * p < 0.05

¹ Insulin glargine was dosed to a target glucose concentration of 4.0 to 5.5 mmol/l (72 to 100 mg/dl). The mean dose of insulin glargine at the beginning of treatment was 10.1 IU/day rising to 31.1 IU/day for insulin glargine-treated patients.

The 156-week results were consistent with those previously reported in the 26-week interim report. Treatment with prolonged-release exenatide persistently significantly improved glycaemic control and weight control, compared to the insulin glargine treatment. Safety findings at 156 weeks were consistent with those reported at 26 weeks.

In a 26-week double-blind study prolonged-release exenatide was compared to maximum daily doses of sitagliptin and pioglitazone in subjects also using metformin. All treatment groups had a significant reduction in HbA_{1c} compared to baseline. Prolonged-release exenatide demonstrated superiority to both sitagliptin and pioglitazone with respect to change in HbA_{1c} from baseline.

Prolonged-release exenatide demonstrated significantly greater weight reductions compared to sitagliptin. Patients on pioglitazone gained weight (Table 4).

Table 4: Results of one 26-week study of prolonged-release exenatide versus sitagliptin and versus pioglitazone in combination with metformin (intent to treat patients)

	Prolonged-release exenatide 2 mg	Sitagliptin 100 mg	Pioglitazone 45 mg
N	160	166	165
Mean HbA_{1c} (%)			
Baseline	8.6	8.5	8.5
Change from baseline (± SE)	-1.6 (± 0.1)*	-0.9 (± 0.1)*	-1.2 (± 0.1)*
Mean difference change from baseline between treatments (95 % CI) versus sitagliptin	-0.63 (-0.89, -0.37)**		
Mean difference change from baseline between treatments (95 % CI) versus pioglitazone	-0.32 (-0.57, -0.06)*		
Patients (%) achieving HbA_{1c} ≤ 7 %	62	36	49
Change in fasting serum glucose (mmol/l) (± SE)	-1.8 (± 0.2)	-0.9 (± 0.2)	-1.5 (± 0.2)
Mean body weight (kg)			
Baseline	89	87	88
Change from baseline (± SE)	-2.3 (± 0.3)	-0.8 (± 0.3)	+2.8 (± 0.3)
Mean difference change from baseline between treatments (95 % CI) versus sitagliptin	-1.54 (-2.35, -0.72)*		
Mean difference change from baseline between treatments (95 % CI) versus pioglitazone	-5.10 (-5.91, -4.28)**		

SE = standard error, CI = confidence interval, *p < 0.05, **p < 0.0001

In a 28-week, double-blind study, the combination of prolonged-release exenatide and dapagliflozin was compared to prolonged-release exenatide alone and dapagliflozin alone in subjects also using metformin. All treatment groups had a reduction in HbA_{1c} compared to baseline. The prolonged-release exenatide and dapagliflozin treatment group showed superior reductions in HbA_{1c} from baseline compared to prolonged-release exenatide alone and dapagliflozin alone (Table 5).

The combination of prolonged-release exenatide and dapagliflozin demonstrated significantly greater weight reductions compared to either medicinal product alone (Table 5).

Table 5: Results of one 28-week study of prolonged-release exenatide and dapagliflozin versus prolonged-release exenatide alone and dapagliflozin alone, in combination with metformin (intent to treat patients)

	Prolonged-release exenatide 2 mg QW + Dapagliflozin 10 mg QD	Prolonged-release exenatide 2 mg QW + Placebo QD	Dapagliflozin 10 mg QD + Placebo QW
N	228	227	230
Mean HbA_{1c} (%)			
Baseline	9.3	9.3	9.3
Change from baseline (±SE) ^a	-2.0 (±0.1)	-1.6 (±0.1)	-1.4 (±0.1)
Mean difference in change from baseline between combination and single		-0.38* (-0.63, -0.13)	-0.59** (-0.84, -0.34)

	Prolonged-release exenatide 2 mg QW + Dapagliflozin 10 mg QD	Prolonged-release exenatide 2 mg QW + Placebo QD	Dapagliflozin 10 mg QD + Placebo QW
active medicinal product (95 % CI)			
Patients (%) achieving HbA_{1c} < 7 %	45	27	19
Mean change from baseline in fasting plasma glucose (mmol/l) (±SE)^a	-3.7 (±0.2)	-2.5 (±0.2)	-2.7 (±0.2)
Mean difference in change from baseline between combination and single active medicinal product (95 % CI)		-1.12** (-1.55, -0.68)	-0.92** (-1.36, -0.49)
Mean change from baseline in 2-hour postprandial plasma glucose (mmol/l) (±SE)^a	-4.9 (±0.2)	-3.3 (±0.2)	-3.4 (±0.2)
Mean difference in change from baseline between combination and single active medicinal product (95 % CI)		-1.54** (-2.10, -0.98)	-1.49** (-2.04, -0.93)
Mean body weight (kg)			
Baseline	92	89	91
Change from baseline (±SE) ^a	-3.6 (±0.3)	-1.6 (±0.3)	-2.2 (±0.3)
Mean difference in change from baseline between combination and single active medicinal product (95 % CI)		-2.00** (-2.79, -1.20)	-1.33** (-2.12, -0.55)

QW=once weekly, QD=once daily, SE = standard error, CI= confidence interval, N=number of patients.

^a Adjusted least squares means (LS Means) and treatment group difference(s) in the change from baseline values at Week 28 are modelled using a mixed model with repeated measures (MMRM) including treatment, region, baseline HbA_{1c} stratum (< 9.0 % or ≥ 9.0 %), week, and treatment by week interaction as fixed factors, and baseline value as a covariate.

*p < 0.01, **p < 0.001.

p-values are all adjusted p-values for multiplicity.

Analyses exclude measurements post rescue therapy and post premature discontinuation of study medicinal product.

In a 28-week double-blind study, prolonged-release exenatide added to insulin glargine alone or with metformin was compared to placebo added to insulin glargine alone or with metformin. Insulin glargine was dosed targeting a fasting plasma glucose of 4.0 to 5.5 mmol/l (72 to 99 mg/dl).

Prolonged-release exenatide demonstrated superiority to placebo in reducing HbA_{1c} from baseline to Week 28 (Table 6).

Prolonged-release exenatide was superior to placebo in reducing body weight at Week 28 (Table 6).

Table 6: Results of one 28-week study of prolonged-release exenatide versus placebo in combination with insulin glargine alone or with metformin (intent to treat patients)

	Prolonged-release exenatide 2 mg + Insulin glargine^a	Placebo + Insulin glargine^a
N	231	230
Mean HbA_{1c} (%)		
Baseline	8.5	8.5
Change from baseline (± SE) ^b	-1.0 (±0.1)	-0.2 (±0.1)
Mean difference in change from baseline between treatments (95% CI)	-0.73* (-0.93, -0.53)	
Patients (%) achieving HbA_{1c} ≤7%^c	33*	7
Mean body weight (kg)		
Baseline	94	94
Change from baseline (± SE) ^b	-1.0 (±0.3)	0.5 (±0.3)
Mean difference in change from baseline between treatments (95% CI)	-1.50* (-2.17, -0.84)	
Change from baseline in 2-hour postprandial plasma glucose (mmol/l) (± SE)^{b,d}	-1.6 (±0.3)	-0.1 (±0.3)
Mean difference in change from baseline between treatments (95% CI)	-1.52* (-2.15, -0.90)	

N=number of patients in each treatment group, SE = standard error, CI= confidence interval, *p-value <0.001 (adjusted for multiplicity).

^a. The LS means change in mean daily insulin dose was 1.6 units for the prolonged-release exenatide group and 3.6 units for the placebo group.

^b. Adjusted LS means and treatment group difference(s) in the change from baseline values at Week 28 are modeled using a mixed model with repeated measures (MMRM) including treatment, region, baseline HbA_{1c} stratum (<9.0% or ≥9.0%), baseline SU-use stratum (yes vs. no), week, and treatment by week interaction as fixed factors, and baseline value as a covariate. The absolute change in 2-hour postprandial plasma glucose at Week 28 is modeled similarly using ANCOVA.

^c. All patients with missing endpoint data are imputed as non-responders.

^d. After a standard meal tolerance test.

Analyses exclude measurements post rescue therapy and post premature discontinuation of study medicinal product.

Body weight

A reduction in body weight compared to baseline has been observed in all prolonged-release exenatide studies. In the 4 comparator-controlled studies, this reduction in body weight was seen in patients treated with prolonged-release exenatide irrespective of the occurrence of nausea although the reduction was larger in the group with nausea (mean reduction of -2.9 kg to -5.2 kg with nausea versus -2.2 kg to -2.9 kg without nausea).

In the 4 comparator-controlled studies, the proportion of patients who had both a reduction in weight and HbA_{1c} ranged from 70 to 79 % (the proportion of patients who had a reduction of HbA_{1c} ranged from 88 to 96 %).

Plasma/serum glucose

Treatment with prolonged-release exenatide resulted in significant reductions in fasting plasma/serum glucose concentrations, these reductions were observed as early as 4 weeks. In the placebo-controlled study with insulin glargine, the change from baseline to Week 28 in fasting plasma glucose was -0.7 mmol/l for the prolonged-release exenatide group and -0.1 mmol/l for the placebo group. Additional reductions in postprandial concentrations were also observed. The improvement in fasting plasma glucose concentrations was durable through 52 weeks.

Beta-cell function

Clinical studies with prolonged-release exenatide have indicated improved beta-cell function, using measures such as the homeostasis model assessments (HOMA-B). The durability of effect on beta-cell function was maintained through 52 weeks.

Blood pressure

A reduction in systolic blood pressure was observed in the 4 comparator-controlled prolonged-release exenatide studies (2.9 mmHg to 4.7 mmHg). In the 30-week immediate-release exenatide comparator study both prolonged-release and immediate-release exenatide significantly reduced systolic blood pressure from base line (4.7±1.1 mmHg and 3.4±1.1 mmHg respectively) the difference between the treatments was not significant. Improvements in blood pressure were maintained through 52 weeks.

In the placebo-controlled study with insulin glargine, the change from baseline to Week 28 in systolic blood pressure was -2.6 mmHg for the prolonged-release exenatide group and -0.7 mmHg for the placebo group.

Treatment with prolonged-release exenatide and dapagliflozin combination at Week 28 resulted in a significant mean change reduction of -4.3±0.8 mmHg in systolic blood pressure compared to prolonged-release exenatide alone of -1.2±0.8 mmHg (p<0.01) or to dapagliflozin alone of -1.8±0.8 mmHg (p<0.05).

Fasting lipids

Prolonged-release exenatide has shown no negative effects on lipid parameters.

Paediatric population

The European Medicines Agency has deferred the obligation to submit the results of studies with prolonged-release exenatide in one or more subsets of the paediatric population in type 2 diabetes mellitus (see section 4.2 for information on paediatric use).

5.2 Pharmacokinetic properties

The absorption properties of exenatide reflect the extended release properties of the prolonged-release exenatide formulation. Once absorbed into the circulation, exenatide is distributed and eliminated according to its known systemic pharmacokinetic properties (as described in this section).

Absorption

Following weekly administration of 2 mg prolonged-release exenatide, mean exenatide concentrations exceeded minimal efficacious concentrations (~ 50 pg/ml) in 2 weeks with gradual increase in the average plasma exenatide concentration over 6 to 7 weeks. Subsequently, exenatide concentrations of approximately 151-265 pg/ml were maintained indicating that steady state was achieved. Steady-state exenatide concentrations are maintained during the one-week interval between doses with minimal peak to trough fluctuation from this average therapeutic concentration.

Distribution

The mean apparent volume of distribution of exenatide following subcutaneous administration of a single dose of exenatide is 28 l.

Biotransformation and elimination

Nonclinical studies have shown that exenatide is predominantly eliminated by glomerular filtration with subsequent proteolytic degradation. The mean apparent clearance of exenatide is 9 l/h. These pharmacokinetic characteristics of exenatide are independent of the dose. Approximately 10 weeks after discontinuation of prolonged-release exenatide therapy, mean plasma exenatide concentrations fell below minimal detectable concentrations.

Special populations

Renal impairment

Population pharmacokinetic analysis of renal impaired patients receiving 2 mg prolonged-release exenatide indicate that there may be an increase in systemic exposure of approximately 74 % and 23 % (median prediction in each group) in moderate (N = 10) and mild (N = 56) renal impaired patients, respectively as compared to normal (N = 84) renal function patients.

Hepatic insufficiency

No pharmacokinetic study has been performed in patients with hepatic insufficiency. Exenatide is cleared primarily by the kidney; therefore hepatic dysfunction is not expected to affect blood concentrations of exenatide.

Gender, race and body weight

Gender, race and body weight have no clinically relevant influence on exenatide pharmacokinetics.

Elderly

Data in elderly are limited, but suggest no marked changes in exenatide exposure with increased age up to about 75 years old.

In a pharmacokinetic study of immediate-release exenatide in patients with type 2 diabetes, administration of exenatide (10 mcg) resulted in a mean increase of exenatide AUC by 36 % in 15 elderly subjects aged 75 to 85 years compared to 15 subjects aged 45 to 65 years likely related to reduced renal function in the older age group (see section 4.2).

Paediatric population

In a single-dose pharmacokinetic study of immediate-release exenatide in 13 patients with type 2 diabetes and between the ages of 12 and 16 years, administration of exenatide (5 mcg) resulted in slightly lower mean AUC (16 % lower) and C_{max} (25 % lower) compared to those observed in adults. No pharmacokinetics study of prolonged-release exenatide has been conducted in the paediatric population.

5.3 Preclinical safety data

Non-clinical data reveal no special hazards for humans based on conventional studies of safety pharmacology, repeat-dose toxicity, or genotoxicity conducted with immediate-release exenatide or prolonged-release exenatide.

Thyroid tumours have been observed in rats and mice with long acting GLP-1 receptor agonists. In a 2-year rat carcinogenicity study with prolonged-release exenatide, an increased incidence of C-cell adenomas and C-cell carcinomas was observed at doses ≥ 2 -fold the human systemic exposure based on AUC. The clinical relevance of these findings is currently unknown.

Animal studies with exenatide did not indicate harmful effects with respect to fertility; high doses of exenatide caused skeletal effects and reduced foetal and neonatal growth.

6. PHARMACEUTICAL PARTICULARS

6.1 List of excipients

Powder

poly (D,L-lactide-co-glycolide)

sucrose

Solvent

carmellose sodium

sodium chloride

polysorbate 20

sodium dihydrogen phosphate monohydrate

disodium phosphate heptahydrate

water for injections

6.2 Incompatibilities

In the absence of compatibility studies this medicinal product must not be mixed with other medicinal products.

6.3 Shelf life

3 years

After suspension

The suspension must be injected immediately after mixing the powder and the solvent.

6.4 Special precautions for storage

Store in a refrigerator (2°C - 8°C).

Do not freeze.

The kit may be kept for up to 4 weeks below 30°C prior to use.

Store in the original package in order to protect from light.

For storage conditions after mixing of the medicinal product, see section 6.3.

6.5 Nature and contents of container

The powder is packaged in a 3 ml Type I glass vial sealed with a chlorobutyl rubber stopper and an aluminium seal with a plastic flip-off cap.

The solvent is packaged in a 1.5 ml Type 1 glass pre-filled syringe sealed with a bromobutyl rubber cap and a rubber plunger.

Each single-dose kit contains one vial of 2 mg exenatide, one pre-filled syringe of 0.65 ml solvent, one vial connector, and two injection needles (one spare).

Pack size of 4 single-dose kits and a multipack consisting of 12 (3 packs of 4) single-dose kits. Not all pack sizes may be marketed.

6.6 Special precautions for disposal and other handling

The patient should be instructed to discard the syringe safely, with the needle still attached after each injection. The patient does not need to save any part of the single-use kit.

The solvent should be visually inspected prior to use. The solvent should only be used if it is clear and free of particulate matter. After suspension, the mixture should only be used if it is white to off white and cloudy.

Prolonged-release exenatide must be injected immediately after suspension of the powder in the solvent.

Prolonged-release exenatide that has been frozen must not be used.

Any unused medicinal product or waste material should be disposed of in accordance with local requirements.

7. MARKETING AUTHORISATION HOLDER

AstraZeneca AB
SE-151 85 Södertälje
Sweden

8. MARKETING AUTHORISATION NUMBER(S)

EU/1/11/696/001-002

9. DATE OF FIRST AUTHORISATION/RENEWAL OF THE AUTHORISATION

Date of first authorisation: 17 June 2011
Date of latest renewal: 18 February 2016

10. DATE OF REVISION OF THE TEXT

Detailed information on this medicinal product is available on the website of the European Medicines Agency <http://www.ema.europa.eu>

1. NAME OF THE MEDICINAL PRODUCT

Bydureon 2 mg powder and solvent for prolonged-release suspension for injection in pre-filled pen

2. QUALITATIVE AND QUANTITATIVE COMPOSITION

Each pre-filled pen contains 2 mg of exenatide. After suspension, each pen delivers a dose of 2 mg in 0.65 ml.

For the full list of excipients, see section 6.1.

3. PHARMACEUTICAL FORM

Powder and solvent for prolonged-release suspension for injection.

Powder: white to off-white powder.

Solvent: clear, colourless to pale yellow to pale brown solution.

4. CLINICAL PARTICULARS

4.1 Therapeutic indications

Bydureon is indicated in adults 18 years and older with type 2 diabetes mellitus to improve glycaemic control in combination with other glucose-lowering medicinal products including basal insulin, when the therapy in use, together with diet and exercise, does not provide adequate glycaemic control (see section 4.4, 4.5 and 5.1 for available data on different combinations).

4.2 Posology and method of administration

Posology

The recommended dose is 2 mg exenatide once weekly.

Patients switching from immediate-release (Byetta) to prolonged-release (Bydureon or Bydureon BCise) exenatide may experience transient elevations in blood glucose concentrations, which generally improve within the first two weeks after initiation of therapy. Patients switching between the prolonged-release exenatide products (Bydureon or Bydureon BCise) may do so, with no expected relevant effect on blood glucose concentrations.

When prolonged-release exenatide is added to existing metformin and/or thiazolidinedione therapy, the current dose of metformin and/or thiazolidinedione can be continued. When added to sulphonylurea therapy, a reduction in the dose of sulphonylurea should be considered to reduce the risk of hypoglycaemia (see section 4.4).

Prolonged-release exenatide should be administered once a week on the same day each week. The day of weekly administration can be changed if necessary as long as the last dose was administered at least three days before. Prolonged-release exenatide can be administered at any time of day, with or without meals.

If a dose is missed, it should be administered as soon as practical, provided the next regularly scheduled dose is due in 3 days or more. Thereafter, patients can resume their usual once weekly dosing schedule.

If a dose is missed and the next regularly scheduled dose is due 1 or 2 days later, the patient should not administer the missed dose, but instead resume prolonged-release exenatide on the next regularly scheduled dosing day.

The use of prolonged-release exenatide does not require additional self-monitoring. Blood glucose self-monitoring may be necessary to adjust the dose of sulphonylurea.

If a different glucose-lowering treatment is started after the discontinuation of prolonged-release exenatide, consideration should be given to the prolonged release of the product (see section 5.2).

Special populations

Elderly

No dose adjustment is required based on age. However, as renal function generally declines with age, consideration should be given to the patient's renal function (see *Renal impairment*). The clinical experience in patients > 75 years is very limited (see section 5.2).

Renal impairment

No dose adjustment is necessary for patients with mild renal impairment (creatinine clearance 50 to 80 ml/min). Clinical experience in patients with moderate renal impairment (creatinine clearance 30 to 50 ml/min) is very limited (see section 5.2). Prolonged-release exenatide is not recommended in these patients.

Prolonged-release exenatide is not recommended for use in patients with end-stage renal disease or severe renal impairment (creatinine clearance < 30 ml/min) (see section 4.4).

Hepatic impairment

No dose adjustment is necessary for patients with hepatic impairment (see section 5.2).

Paediatric population

The safety and efficacy of prolonged-release exenatide in children and adolescents aged under 18 years have not yet been established. Currently available data are described in section 5.2 but no recommendation on a posology can be made.

Method of administration

Subcutaneous use

Prolonged-release exenatide is for self-administration by the patient. Each pen can only be used by one person and is for single use.

Prior to initiation of prolonged-release exenatide, it is strongly recommended that patients and caregivers be trained by their healthcare professional. The "Instructions for the User", provided in the carton, must be followed carefully.

Each dose should be administered in the abdomen, thigh, or the back of the upper arm as a subcutaneous injection immediately after suspension of the powder in the solvent.

When used with insulin, prolonged-release exenatide and insulin must be administered as two separate injections.

For instructions on the suspension of the medicinal product before administration, see section 6.6 and the "Instructions for the User".

4.3 Contraindications

Hypersensitivity to the active substance or to any of the excipients listed in section 6.1.

4.4 Special warnings and precautions for use

Prolonged-release exenatide should not be used in patients with type 1 diabetes mellitus or for the treatment of diabetic ketoacidosis.

Prolonged-release exenatide must not be administered by intravenous or intramuscular injection.

Renal impairment

In patients with end-stage renal disease receiving dialysis, single doses of immediate-release exenatide increased frequency and severity of gastrointestinal adverse reactions; therefore, prolonged-release exenatide is not recommended for use in patients with end-stage renal disease or severe renal impairment (creatinine clearance < 30 ml/min). The clinical experience in patients with moderate renal impairment is very limited and the use of prolonged-release exenatide is not recommended.

There have been uncommon events of altered renal function with exenatide, including increased serum creatinine, renal impairment, worsened chronic renal failure and acute renal failure, sometimes requiring haemodialysis. Some of these events occurred in patients experiencing events that may affect hydration, including nausea, vomiting, and/or diarrhoea and/or receiving medicinal products known to affect renal function/hydration status. Concomitant medicinal products included angiotensin converting enzymes inhibitors, angiotensin-II antagonists, non-steroidal anti-inflammatory medicinal products and diuretics. Reversibility of altered renal function has been observed with supportive treatment and discontinuation of potentially causative medicinal products, including exenatide.

Severe gastrointestinal disease

Prolonged-release exenatide has not been studied in patients with severe gastrointestinal disease, including gastroparesis. Its use is commonly associated with gastrointestinal adverse reactions, including nausea, vomiting, and diarrhoea. Therefore, the use of prolonged-release exenatide is not recommended in patients with severe gastrointestinal disease.

Acute pancreatitis

Use of GLP-1 receptor agonists has been associated with a risk of developing acute pancreatitis. In clinical studies of prolonged-release exenatide, acute pancreatitis occurred in 0.3% of patients. There have been spontaneously reported events of acute pancreatitis with prolonged-release exenatide. Resolution of pancreatitis has been observed with supportive treatment, but very rare cases of necrotising or haemorrhagic pancreatitis and/or death have been reported. Patients should be informed of the characteristic symptom of acute pancreatitis: persistent, severe abdominal pain. If pancreatitis is suspected, prolonged-release exenatide should be discontinued; if acute pancreatitis is confirmed, prolonged-release exenatide should not be restarted. Caution should be exercised in patients with a history of pancreatitis.

Concomitant medicinal products

The concurrent use of prolonged-release exenatide with D-phenylalanine derivatives (meglitinides), alpha-glucosidase inhibitors, dipeptidyl peptidase-4 inhibitors or other GLP-1 receptor agonists has not been studied. The concurrent use of prolonged-release and immediate-release exenatide has not been studied and is not recommended.

Interaction with warfarin

There have been spontaneously reported cases of increased INR (International Normalized Ratio), sometimes associated with bleeding, with concomitant use of warfarin and exenatide (see section 4.5).

Hypoglycaemia

The risk of hypoglycaemia was increased when prolonged-release exenatide was used in combination with a sulphonylurea in clinical studies. Furthermore, in the clinical studies, patients on a sulphonylurea combination, with mild renal impairment had an increased incidence of hypoglycaemia compared to patients with normal renal function. To reduce the risk of hypoglycaemia associated with the use of a sulphonylurea, reduction in the dose of sulphonylurea should be considered.

Rapid weight loss

Rapid weight loss at a rate of > 1.5 kg per week has been reported in patients treated with exenatide. Weight loss of this rate may have harmful consequences. Patients with rapid weight loss should be monitored for signs and symptoms of cholelithiasis.

Discontinuation of treatment

After discontinuation, the effect of prolonged-release exenatide may continue as plasma levels of exenatide decline over 10 weeks. Choice of other medicinal products and dose selection should be considered accordingly, as adverse reactions may continue and efficacy may, at least partly, persist until exenatide levels decline.

Excipients

Sodium content: This medicinal product contains less than 1 mmol sodium (23 mg) per dose, i.e. essentially “sodium-free”.

4.5 Interaction with other medicinal products and other forms of interaction

Sulphonylureas

The dose of a sulphonylurea may require adjustment due to the increased risk of hypoglycaemia associated with sulphonylurea therapy (see sections 4.2 and 4.4).

Gastric emptying

The results of a study using paracetamol as a marker of gastric emptying suggest that the effect of prolonged-release exenatide to slow gastric emptying is minor and not expected to cause clinically significant reductions in the rate and extent of absorption of concomitantly administered oral medicinal products. Therefore, no dose adjustments for medicinal products sensitive to delayed gastric emptying are required.

When 1,000 mg paracetamol tablets were administered, either with or without a meal, following 14 weeks of prolonged-release exenatide therapy, no significant changes in paracetamol AUC were observed compared to the control period. Paracetamol C_{max} decreased by 16 % (fasting) and 5 % (fed) and t_{max} was increased from approximately 1 hour in the control period to 1.4 hours (fasting) and 1.3 hours (fed).

The following interaction studies have been conducted using 10 mcg immediate-release exenatide but not prolonged-release exenatide:

Warfarin

A delay in t_{max} of about 2 h was observed when warfarin was administered 35 min after immediate-release exenatide. No clinically relevant effects on C_{max} or AUC were observed. Increased INR has been spontaneously reported during concomitant use of warfarin and prolonged-release exenatide. INR should be monitored during initiation of prolonged-release exenatide therapy in patients on warfarin and/or coumarin derivatives (see sections 4.4 and 4.8).

Hydroxy methyl glutaryl coenzyme A reductase inhibitors

Lovastatin AUC and C_{max} were decreased approximately 40 % and 28 %, respectively, and t_{max} was delayed about 4 h when immediate-release exenatide was administered concomitantly with a single dose of lovastatin (40 mg) compared with lovastatin administered alone. In 30-week placebo-controlled clinical studies with immediate-release exenatide, concomitant use of exenatide and HMG CoA reductase inhibitors was not associated with consistent changes in lipid profiles (see section 5.1). No predetermined dose adjustment is required; however, lipid profiles should be monitored as appropriate.

Digoxin and lisinopril

In interaction studies of the effect of immediate-release exenatide on digoxin and lisinopril there were no clinically relevant effects on C_{max} or AUC, however, a delay in t_{max} of about 2 h was observed.

Ethinyl estradiol and levonorgestrel

Administration of a combination oral contraceptive (30 mcg ethinyl estradiol plus 150 mcg levonorgestrel) one hour before immediate-release exenatide did not alter the AUC, C_{max} or C_{min} of either ethinyl estradiol or levonorgestrel. Administration of the oral contraceptive 35 minutes after exenatide did not affect AUC but resulted in a reduction of the C_{max} of ethinyl estradiol by 45 %, and C_{max} of levonorgestrel by 27-41 %, and a delay in t_{max} by 2-4 h due to delayed gastric emptying. The reduction in C_{max} is of limited clinical relevance and no adjustment of dosing of oral contraceptives is required.

Paediatric population

Interaction studies with exenatide have only been performed in adults.

4.6 Fertility, pregnancy and lactation

Women of childbearing potential

Due to the long washout period of prolonged-release exenatide, women of childbearing potential should use contraception during treatment with prolonged-release exenatide. This medicinal product should be discontinued at least 3 months before a planned pregnancy.

Pregnancy

There are no adequate data from the use of prolonged-release exenatide in pregnant women. Studies in animals have shown reproductive toxicity (see section 5.3). The potential risk for humans is unknown. Prolonged-release exenatide should not be used during pregnancy and the use of insulin is recommended.

Breast-feeding

It is unknown whether exenatide is excreted in human milk. Prolonged-release exenatide should not be used during breast-feeding.

Fertility

No fertility studies in humans have been conducted.

4.7 Effects on ability to drive and use machines

Prolonged-release exenatide has minor influence on the ability to drive and use machines. When prolonged-release exenatide is used in combination with a sulphonylurea, patients should be advised to take precautions to avoid hypoglycaemia while driving and using machines.

4.8 Undesirable effects

Summary of the safety profile

The most frequent adverse reactions were mainly gastrointestinal related (nausea which was the most frequent reaction and associated with the initiation of treatment and decreased over time, and diarrhoea). In addition, injection site reactions (pruritus, nodules, erythema), hypoglycaemia (with a sulphonylurea), and headache occurred. Most adverse reactions associated with prolonged-release exenatide were mild to moderate in intensity.

Tabulated list of adverse reactions

The frequency of adverse reactions of prolonged-release exenatide identified from clinical studies and spontaneous reports (not observed in clinical studies, frequency not known) are summarised in Table 1 below.

In the prolonged-release exenatide clinical studies, background therapies included diet and exercise, metformin, a sulphonylurea, a thiazolidinedione, a combination of oral glucose-lowering medicinal products or a basal insulin.

The reactions are listed below as MedDRA preferred term by system organ class and absolute frequency. Frequencies are defined as: very common ($\geq 1/10$), common ($\geq 1/100$ to $< 1/10$), uncommon ($\geq 1/1,000$ to $< 1/100$), rare ($\geq 1/10,000$ to $< 1/1000$), very rare ($< 1/10,000$) and not known (cannot be estimated from the available data).

Table 1: Adverse reactions of prolonged-release exenatide identified from clinical studies and spontaneous reports

System organ class /adverse reaction terms	Frequency of occurrence					
	Very common	Common	Uncommon	Rare	Very rare	Not known
Immune system disorders						
Anaphylactic reaction				X ¹		
Metabolism and nutrition disorders						
Hypoglycaemia (with a sulphonylurea)	X ¹					
Hypoglycaemia (with insulin)		X ^{2,3}				
Decreased appetite		X ¹				
Dehydration			X ¹			
Nervous system disorders						
Headache		X ¹				
Dizziness		X ¹				
Dysgeusia			X ¹			
Somnolence			X ¹			
Gastrointestinal disorders						
Intestinal obstruction			X ¹			
Acute pancreatitis (see section 4.4)			X ¹			
Nausea	X ¹					
Vomiting		X ¹				
Diarrhoea	X ¹					
Dyspepsia		X ¹				
Abdominal pain		X ¹				
Gastroesophageal reflux disease		X ¹				
Abdominal distension		X ¹				
Eructation			X ¹			
Constipation		X ¹				
Flatulence		X ¹				
Skin and subcutaneous tissue disorders						
Macular and papular rash						X ⁴
Pruritus, and/ or urticaria		X ¹				
Angioneurotic oedema						X ⁴
Injection site abscesses and cellulitis						X ⁴
Hyperhidrosis			X ¹			
Alopecia			X ¹			

System organ class /adverse reaction terms	Frequency of occurrence					
	Very common	Common	Uncommon	Rare	Very rare	Not known
Renal and urinary disorders						
Altered renal function, including acute renal failure, worsened chronic renal failure, renal impairment, increased serum creatinine (see section 4.4).			X ¹			
General disorders and administration site conditions						
Injection site pruritus		X ¹				
Fatigue		X ¹				
Injection site erythema		X ¹				
Injection site rash			X ¹			
Asthenia		X ¹				
Feeling jittery				X ¹		
Investigations						
International normalised ratio increased (see section 4.4)						X ⁴

¹ Rate based on twelve prolonged-release exenatide completed long-term efficacy and safety studies n=2868 total (patients on sulphonylurea n=1002).

² Based on hypoglycaemic events that 1. Result in loss of consciousness, seizure, or coma which resolves after administration of glucagon or glucose OR 2. Require third-party assistance to resolve because of impairment in consciousness or behaviour and has glucose value of <54 mg/dL (3 mmol/L) OR 3. Result in symptoms consistent with hypoglycaemia with a concomitant glucose <54 mg/dL (3 mmol/L) prior to treatment.

³ Frequency reported from the 28-week controlled treatment period of the prolonged-release exenatide as add-on to insulin glargine study (N=232).

⁴ Rate based on prolonged-release exenatide spontaneous reports data (unknown denominator).

Description of selected adverse reactions

Hypoglycaemia

The incidence of hypoglycaemia was increased when prolonged-release exenatide was used in combination with a sulphonylurea (24.0 % versus 5.4 %) (see section 4.4). To reduce the risk of hypoglycaemia associated with the use of a sulphonylurea, reduction in the dose of sulphonylurea may be considered (see sections 4.2 and 4.4).

Prolonged-release exenatide was associated with a significantly lower incidence of episodes of hypoglycaemia than basal insulin in patients also receiving metformin therapy (3 % versus 19 %) and in patients also receiving metformin plus sulphonylurea therapy (20 % versus 42 %).

Across 12 studies of prolonged-release exenatide most episodes (99.9 % n = 649) of hypoglycaemia were minor, and resolved with oral administration of carbohydrate. One patient was reported with major hypoglycaemia since he had a low blood glucose value (2.2 mmol/l) and requested assistance with oral carbohydrate treatment which resolved the event.

When prolonged-release exenatide was added to basal insulin, no initial dose adjustment of insulin was required. Prolonged-release exenatide in combination with basal insulin showed no clinically

significant differences in the incidence of hypoglycaemic episodes compared to insulin. There were no episodes of major hypoglycaemia in the prolonged-release exenatide with insulin group.

Nausea

The most frequently reported adverse reaction was nausea. In patients treated with prolonged-release exenatide, generally 20 % reported at least one episode of nausea compared to 34 % of immediate-release exenatide patients. Most episodes of nausea were mild to moderate. With continued therapy, the frequency decreased in most patients who initially experienced nausea.

The incidence of withdrawal due to adverse events during the 30-week controlled study was 6 % for prolonged-release exenatide treated patients, 5 % for immediate-release exenatide treated patients. The most common adverse events leading to withdrawal in either treatment group were nausea and vomiting. Withdrawal due to nausea or vomiting each occurred in < 1 % for prolonged-release exenatide treated patients and 1 % for immediate-release exenatide treated patients.

Injection site reactions

Injection site reactions were observed more frequently in prolonged-release exenatide treated patients versus comparator-treated patients (16 % versus range of 2-7 %) during the 6-month controlled phase of studies. These injection site reactions were generally mild and usually did not lead to withdrawal from studies. Patients may be treated to relieve symptoms, while continuing treatment. Subsequent injections should use a different site of injection each week. In postmarketing experiences, cases with injection site abscesses and cellulitis have been reported.

Small subcutaneous injection site nodules were observed very frequently in clinical studies, consistent with the known properties of poly (D,L-lactide co-glycolide) polymer microsphere formulations. Most individual nodules were asymptomatic, did not interfere with study participation and resolved over 4 to 8 weeks.

Immunogenicity

Consistent with the potentially immunogenic properties of protein and peptide pharmaceuticals, patients may develop antibodies to exenatide following treatment with prolonged-release exenatide. In most patients who develop antibodies, antibody titres diminish over time.

The presence of antibodies (high or low titres) is not predictive of glycaemic control for an individual patient.

In clinical studies of prolonged-release exenatide, approximately 45 % of patients had low titre antibodies to exenatide at study endpoint. Overall the percentage of antibody positive patients was consistent across clinical studies. Overall, the level of glycaemic control (HbA_{1c}) was comparable to that observed in those without antibody titres. On average in the phase 3 studies, 12 % of the patients had higher titre antibodies. In a proportion of these the glycaemic response to prolonged-release exenatide was absent at the end of the controlled period of studies; 2.6 % of patients showed no glucose improvement with higher titre antibodies whereas 1.6 % showed no improvement while antibody negative.

Patients who developed antibodies to exenatide tend to have more injection site reactions (for example: redness of skin and itching), but otherwise similar rates and types of adverse events as those with no antibodies to exenatide.

For prolonged-release exenatide treated patients, the incidence of potentially immunogenic injection site reactions (most commonly pruritus with or without erythema) during the 30-week and the two 26-week studies was 9 %. These reactions were less commonly observed in antibody-negative patients (4 %) compared with antibody-positive patients (13 %), with a greater incidence in those with higher titre antibodies.

Examination of antibody-positive specimens revealed no significant cross-reactivity with similar endogenous peptides (glucagon or GLP-1).

Rapid weight loss

In a 30-week study, approximately 3 % (n = 4/148) of prolonged-release exenatide treated patients experienced at least one time period of rapid weight loss (recorded body weight loss between two consecutive study visits of greater than 1.5 kg/week).

Increased heart rate

A mean increase in heart rate (HR) of 2.6 beats per minute (bpm) from baseline (74 bpm) was observed in pooled prolonged-release exenatide clinical studies. Fifteen percent of prolonged-release exenatide treated patients had mean increases in HR of ≥ 10 bpm; approximately 5 % to 10 % of subjects within the other treatment groups had mean increases in HR of ≥ 10 bpm.

Reporting of suspected adverse reactions

Reporting suspected adverse reactions after authorisation of the medicinal product is important. It allows continued monitoring of the benefit/risk balance of the medicinal product. Healthcare professionals are asked to report any suspected adverse reactions via [the national reporting system listed in Appendix V](#).

4.9 Overdose

Effects of overdoses with exenatide (based on immediate-release exenatide clinical studies) included severe nausea, severe vomiting and rapidly declining blood glucose concentrations. In the event of overdose, appropriate supportive treatment should be initiated according to the patient's clinical signs and symptoms.

5. PHARMACOLOGICAL PROPERTIES

5.1 Pharmacodynamic properties

Pharmacotherapeutic group: Drugs used in diabetes, glucagon-like peptide-1 (GLP-1) analogues, ATC code: A10BJ01.

Mechanism of action

Exenatide is a glucagon-like peptide-1 (GLP-1) receptor agonist that exhibits several antihyperglycaemic actions of glucagon-like peptide-1 (GLP-1). The amino acid sequence of exenatide partially overlaps that of human GLP-1. Exenatide has been shown to bind to and activate the known human GLP-1 receptor *in vitro*, its mechanism of action mediated by cyclic AMP and/or other intracellular signalling pathways.

Exenatide increases, on a glucose-dependent basis, the secretion of insulin from pancreatic beta cells. As blood glucose concentrations decrease, insulin secretion subsides. When exenatide was used in combination with metformin and/or a thiazolidinedione, no increase in the incidence of hypoglycaemia was observed over that of placebo in combination with metformin and/or a thiazolidinedione which may be due to this glucose-dependent insulinotropic mechanism (see section 4.4).

Exenatide suppresses glucagon secretion which is known to be inappropriately elevated in patients with type 2 diabetes. Lower glucagon concentrations lead to decreased hepatic glucose output. However, exenatide does not impair the normal glucagon response and other hormone responses to hypoglycaemia.

Exenatide slows gastric emptying thereby reducing the rate at which meal-derived glucose appears in the circulation.

Administration of exenatide has been shown to reduce food intake, due to decreased appetite and increased satiety.

Pharmacodynamic effects

Exenatide improves glycaemic control through the sustained effects of lowering both postprandial and fasting glucose concentrations in patients with type 2 diabetes. Unlike native GLP-1, prolonged-release exenatide has a pharmacokinetic and pharmacodynamic profile in humans suitable for once weekly administration.

A pharmacodynamic study with exenatide demonstrated in patients with type 2 diabetes (n = 13) a restoration of first phase insulin secretion and improved second phase insulin secretion in response to an intravenous bolus of glucose.

Clinical efficacy and safety

The results of long-term clinical studies of prolonged-release exenatide are presented below; these studies comprised 1356 subjects treated with prolonged-release exenatide, 52 % men and 48 % women, 230 subjects (17 %) were ≥ 65 years of age.

Glycaemic control

In two studies prolonged-release exenatide 2 mg once weekly has been compared to immediate-release exenatide 5 mcg given twice daily for 4 weeks followed by immediate-release exenatide 10 mcg given twice daily. One study was of 24 weeks in duration (n = 252) and the other of 30 weeks (n = 295) followed by an open labelled extension where all patients were treated with prolonged-release exenatide 2 mg once weekly for a further 7 years (n = 258). In both studies, decreases in HbA_{1c} were evident in both treatment groups as early as the first post-treatment HbA_{1c} measurement (weeks 4 or 6).

Prolonged-release exenatide resulted in a statistically significant reduction in HbA_{1c} compared to patients receiving immediate-release exenatide (Table 2).

A clinically relevant effect of prolonged-release exenatide and immediate-release exenatide treated subjects was observed on HbA_{1c}, regardless of the background anti-diabetic therapy in both studies.

Clinically and statistically significantly more subjects on prolonged-release compared to immediate-release exenatide patients achieved an HbA_{1c} reduction of ≤ 7 % or < 7 % in the two studies (p < 0.05 and p \leq 0.0001 respectively).

Both prolonged-release and immediate-release exenatide patients achieved a reduction in weight compared to baseline, although the difference between the two treatment arms was not significant.

In the uncontrolled study extension, evaluable patients who switched from immediate release to prolonged-release exenatide at week 30 (n = 121), achieved the same improvement in HbA_{1c} of -2.0 % at week 52 compared to baseline as patients treated with prolonged-release exenatide.

For all patients completing the uncontrolled study extension of 7 years (n = 122 of 258 patients included in the extension phase), HbA_{1c} gradually increased over time from week 52 onwards, but was still reduced compared to baseline after 7 years (-1.5 %). Weight loss was sustained over 7 years in these patients.

Table 2: Results of two studies of prolonged-release versus immediate-release exenatide in combination with diet and exercise alone, metformin and/or sulphonylurea and metformin and/or thiazolidinedione (intent to treat patients)

24-Week Study	Prolonged-release exenatide 2 mg	Immediate-release exenatide 10 mcg twice daily
N	129	123
Mean HbA_{1c} (%)		

24-Week Study	Prolonged-release exenatide 2 mg	Immediate-release exenatide 10 mcg twice daily
Baseline	8.5	8.4
Change from baseline (\pm SE)	-1.6 (\pm 0.1)**	-0.9 (\pm 0.1)
Mean difference change from baseline between treatments (95 % CI)	-0.67 (-0.94, -0.39)**	
Patients (%) achieving HbA_{1c} < 7 %	58	30
Change in fasting plasma glucose (mmol/l) (\pm SE)	-1.4 (\pm 0.2)	-0.3 (\pm 0.2)
Mean body weight (kg)		
Baseline	97	94
Change from baseline (\pm SE)	-2.3 (\pm 0.4)	-1.4 (\pm 0.4)
Mean difference change from baseline between treatments (95 % CI)	-0.95 (-1.91, 0.01)	
30-Week Study		
N	148	147
Mean HbA_{1c} (%)		
Baseline	8.3	8.3
Change from baseline (\pm SE)	-1.9 (\pm 0.1)*	-1.5 (\pm 0.1)
Mean difference change from baseline between treatments (95 % CI)	-0.33 (-0.54, -0.12)*	
Patients (%) achieving HbA_{1c} \leq 7 %	73	57
Change in fasting plasma glucose (mmol/l) (\pm SE)	-2.3 (\pm 0.2)	-1.4 (\pm 0.2)
Mean body weight (kg)		
Baseline	102	102
Change from baseline (\pm SE)	-3.7 (\pm 0.5)	-3.6 (\pm 0.5)
Mean difference change from baseline between treatments (95 % CI)	-0.08 (-1.29, 1.12)	

SE = standard error, CI = confidence interval, * p < 0.05, **p < 0.0001

A study of 26-week duration has been conducted, in which prolonged-release exenatide 2 mg is compared to insulin glargine once daily. Compared with insulin glargine treatment, prolonged-release exenatide demonstrated a superior change in HbA_{1c}, significantly lowered mean body weight and was associated with fewer hypoglycaemic events (Table 3).

Table 3: Results of one 26-week study of prolonged-release exenatide versus insulin glargine in combination with metformin alone or metformin and sulphonylurea (intent to treat patients)

	Prolonged-release exenatide 2 mg	Insulin glargine¹
N	233	223
Mean HbA_{1c} (%)		
Baseline	8.3	8.3
Change from baseline (± SE)	-1.5 (± 0.1)*	-1.3 (± 0.1)*
Mean difference change from baseline between treatments (95 % CI)	-0.16 (-0.29, -0.03)*	
Patients (%) achieving HbA_{1c} ≤ 7 %	62	54
Change in fasting serum glucose (mmol/l) (± SE)	-2.1 (± 0.2)	-2.8 (± 0.2)
Mean body weight (kg)		
Baseline	91	91
Change from baseline (± SE)	-2.6 (± 0.2)	+1.4 (± 0.2)
Mean difference change from baseline between treatments (95 % CI)	-4.05 (-4.57, -3.52)*	

SE = standard error, CI = confidence interval, * p < 0.05

¹ Insulin glargine was dosed to a target glucose concentration of 4.0 to 5.5 mmol/l (72 to 100 mg/dl). The mean dose of insulin glargine at the beginning of treatment was 10.1 IU/day rising to 31.1 IU/day for insulin glargine-treated patients.

The 156-week results were consistent with those previously reported in the 26-week interim report. Treatment with prolonged-release exenatide persistently significantly improved glycaemic control and weight control, compared to the insulin glargine treatment. Safety findings at 156 weeks were consistent with those reported at 26 weeks.

In a 26-week double-blind study prolonged-release exenatide was compared to maximum daily doses of sitagliptin and pioglitazone in subjects also using metformin. All treatment groups had a significant reduction in HbA_{1c} compared to baseline. Prolonged-release exenatide demonstrated superiority to both sitagliptin and pioglitazone with respect to change in HbA_{1c} from baseline.

Prolonged-release exenatide demonstrated significantly greater weight reductions compared to sitagliptin. Patients on pioglitazone gained weight (Table 4).

Table 4: Results of one 26-week study of prolonged-release exenatide versus sitagliptin and versus pioglitazone in combination with metformin (intent to treat patients)

	Prolonged-release exenatide 2 mg	Sitagliptin 100 mg	Pioglitazone 45 mg
N	160	166	165
Mean HbA_{1c} (%)			
Baseline	8.6	8.5	8.5
Change from baseline (± SE)	-1.6 (± 0.1)*	-0.9 (± 0.1)*	-1.2 (± 0.1)*
Mean difference change from baseline between treatments (95 % CI) versus sitagliptin	-0.63 (-0.89, -0.37)**		
Mean difference change from baseline between treatments (95 % CI) versus pioglitazone	-0.32 (-0.57, -0.06)*		
Patients (%) achieving HbA_{1c} ≤ 7 %	62	36	49
Change in fasting serum glucose (mmol/l) (± SE)	-1.8 (± 0.2)	-0.9 (± 0.2)	-1.5 (± 0.2)
Mean body weight (kg)			
Baseline	89	87	88
Change from baseline (± SE)	-2.3 (± 0.3)	-0.8 (± 0.3)	+2.8 (± 0.3)
Mean difference change from baseline between treatments (95 % CI) versus sitagliptin	-1.54 (-2.35, -0.72)*		
Mean difference change from baseline between treatments (95 % CI) versus pioglitazone	-5.10 (-5.91, -4.28)**		

SE = standard error, CI = confidence interval), * p < 0.05, **p < 0.0001

In a 28-week, double-blind study, the combination of prolonged-release exenatide and dapagliflozin was compared to prolonged-release exenatide alone and dapagliflozin alone in subjects also using metformin. All treatment groups had a reduction in HbA_{1c} compared to baseline. The prolonged-release exenatide and dapagliflozin treatment group showed superior reductions in HbA_{1c} from baseline compared to prolonged-release exenatide alone and dapagliflozin alone (Table 5).

The combination of prolonged-release exenatide and dapagliflozin demonstrated significantly greater weight reductions compared to either medicinal product alone (Table 5).

Table 5: Results of one 28-week study of prolonged-release exenatide and dapagliflozin versus prolonged-release exenatide alone and dapagliflozin alone, in combination with metformin (intent to treat patients)

	Prolonged-release exenatide 2 mg QW + Dapagliflozin 10 mg QD	Prolonged-release exenatide 2 mg QW + Placebo QD	Dapagliflozin 10 mg QD + Placebo QW
N	228	227	230
Mean HbA_{1c} (%)			
Baseline	9.3	9.3	9.3
Change from baseline (±SE) ^a	-2.0 (±0.1)	-1.6 (±0.1)	-1.4 (±0.1)
Mean difference in change from baseline between combination and single active medicinal product (95 % CI)		-0.38* (-0.63, -0.13)	-0.59** (-0.84, -0.34)
Patients (%) achieving HbA_{1c} < 7 %	45	27	19
Mean change from baseline in fasting plasma glucose (mmol/l) (±SE)^a	-3.7 (±0.2)	-2.5 (±0.2)	-2.7 (±0.2)
Mean difference in change from baseline between combination and single active medicinal product (95% CI)		-1.12** (-1.55, -0.68)	-0.92** (-1.36, -0.49)
Mean change from baseline in 2-hour postprandial plasma glucose (mmol/L) (±SE)^a	-4.9 (±0.2)	-3.3 (±0.2)	-3.4 (±0.2)
Mean difference in change from baseline between combination and single active medicinal product (95 % CI)		-1.54** (-2.10, -0.98)	-1.49** (-2.04, -0.93)
Mean body weight (kg)			
Baseline	92	89	91
Change from baseline (±SE) ^a	-3.6 (±0.3)	-1.6 (±0.3)	-2.2 (±0.3)
Mean difference in change from baseline between combination and single active medicinal product (95 % CI)		-2.00** (-2.79, -1.20)	-1.33** (-2.12, -0.55)

QW=once weekly, QD=once daily, SE = standard error, CI= confidence interval, N=number of patients.

^a Adjusted least squares means (LS Means) and treatment group difference(s) in the change from baseline values at Week 28 are modelled using a mixed model with repeated measures (MMRM) including treatment, region, baseline HbA_{1c} stratum (< 9.0 % or ≥ 9.0 %), week, and treatment by week interaction as fixed factors, and baseline value as a covariate.

*p < 0.01, **p < 0.001.

p-values are all adjusted p-values for multiplicity.

Analyses exclude measurements post rescue therapy and post premature discontinuation of study medicinal product.

In a 28-week double-blind study, prolonged-release exenatide added to insulin glargine alone or with metformin was compared to placebo added to insulin glargine alone or with metformin. Insulin glargine was dosed targeting a fasting plasma glucose of 4.0 to 5.5 mmol/l (72 to 99 mg/dl). Prolonged-release exenatide demonstrated superiority to placebo in reducing HbA_{1c} from baseline to Week 28 (Table 6).

Prolonged-release exenatide was superior to placebo in reducing body weight at Week 28 (Table 6).

Table 6: Results of one 28-week study of prolonged-release exenatide versus placebo in combination with insulin glargine alone or with metformin (intent to treat patients)

	Prolonged-release exenatide 2 mg + Insulin glargine^a	Placebo + Insulin glargine^a
N	231	230
Mean HbA_{1c} (%)		
Baseline	8.5	8.5
Change from baseline (± SE) ^b	-1.0 (±0.1)	-0.2 (±0.1)
Mean difference in change from baseline between treatments (95% CI)	-0.73* (-0.93, -0.53)	
Patients (%) achieving HbA_{1c} ≤7%^c	33*	7
Mean body weight (kg)		
Baseline	94	94
Change from baseline (± SE) ^b	-1.0 (±0.3)	0.5 (±0.3)
Mean difference in change from baseline between treatments (95% CI)	-1.50* (-2.17, -0.84)	
Change from baseline in 2-hour postprandial plasma glucose (mmol/l) (± SE)^{b,d}	-1.6 (±0.3)	-0.1 (±0.3)
Mean difference in change from baseline between treatments (95% CI)	-1.52* (-2.15, -0.90)	

N=number of patients in each treatment group, SE = standard error, CI= confidence interval, *p-value <0.001 (adjusted for multiplicity).

^a. The LS means change in mean daily insulin dose was 1.6 units for the prolonged-release exenatide group and 3.6 units for the placebo group.

^b. Adjusted LS means and treatment group difference(s) in the change from baseline values at Week 28 are modeled using a mixed model with repeated measures (MMRM) including treatment, region, baseline HbA_{1c} stratum (<9.0% or ≥9.0%), baseline SU-use stratum (yes vs. no), week, and treatment by week interaction as fixed factors, and baseline value as a covariate. The absolute change in 2-hour postprandial plasma glucose at Week 28 is modeled similarly using ANCOVA.

^c. All patients with missing endpoint data are imputed as non-responders.

^d. After a standard meal tolerance test.

Analyses exclude measurements post rescue therapy and post premature discontinuation of study medication.

Body weight

A reduction in body weight compared to baseline has been observed in all prolonged-release exenatide studies. In the 4 comparator-controlled studies, this reduction in body weight was seen in patients treated with prolonged-release exenatide irrespective of the occurrence of nausea although the reduction was larger in the group with nausea (mean reduction of -2.9 kg to -5.2 kg with nausea versus -2.2 kg to -2.9 kg without nausea).

In the 4 comparator-controlled studies, the proportion of patients who had both a reduction in weight and HbA_{1c} ranged from 70 to 79 % (the proportion of patients who had a reduction of HbA_{1c} ranged from 88 to 96 %).

Plasma/serum glucose

Treatment with prolonged-release exenatide resulted in significant reductions in fasting plasma/serum glucose concentrations, these reductions were observed as early as 4 weeks. In the placebo-controlled study with insulin glargine, the change from baseline to Week 28 in fasting plasma glucose was -0.7 mmol/l for the prolonged-release exenatide group and -0.1 mmol/l for the placebo group. Additional reductions in postprandial concentrations were also observed. The improvement in fasting plasma glucose concentrations was durable through 52 weeks.

Beta-cell function

Clinical studies with prolonged-release exenatide have indicated improved beta-cell function, using measures such as the homeostasis model assessments (HOMA-B). The durability of effect on beta-cell function was maintained through 52 weeks.

Blood pressure

A reduction in systolic blood pressure was observed in the 4 comparator-controlled prolonged-release exenatide studies (2.9 mmHg to 4.7 mmHg). In the 30-week immediate-release exenatide comparator study both prolonged-release and immediate-release exenatide significantly reduced systolic blood pressure from base line (4.7±1.1 mmHg and 3.4±1.1 mmHg respectively) the difference between the treatments was not significant. Improvements in blood pressure were maintained through 52 weeks.

In the placebo-controlled study with insulin glargine, the change from baseline to Week 28 in systolic blood pressure was -2.6 mmHg for the prolonged-release exenatide group and -0.7 mmHg for the placebo group.

Treatment with prolonged-release exenatide and dapagliflozin combination at Week 28 resulted in a significant mean change reduction of -4.3±0.8 mmHg in systolic blood pressure compared to prolonged-release exenatide alone of -1.2±0.8 mmHg ($p<0.01$) or to dapagliflozin alone of -1.8±0.8 mmHg ($p<0.05$).

Fasting lipids

Prolonged-release exenatide has shown no negative effects on lipid parameters.

Paediatric population

The European Medicines Agency has deferred the obligation to submit the results of studies with prolonged-release exenatide in one or more subsets of the paediatric population in type 2 diabetes mellitus (see section 4.2 for information on paediatric use).

5.2 Pharmacokinetic properties

The absorption properties of exenatide reflect the extended release properties of the prolonged-release exenatide formulation. Once absorbed into the circulation, exenatide is distributed and eliminated according to its known systemic pharmacokinetic properties (as described in this section).

Absorption

Following weekly administration of 2 mg prolonged-release exenatide, mean exenatide concentrations exceeded minimal efficacious concentrations (~ 50 pg/ml) in 2 weeks with gradual increase in the average plasma exenatide concentration over 6 to 7 weeks. Subsequently, exenatide concentrations of approximately 151-265 pg/ml were maintained indicating that steady state was achieved. Steady-state exenatide concentrations are maintained during the one-week interval between doses with minimal peak to trough fluctuation from this average therapeutic concentration.

Distribution

The mean apparent volume of distribution of exenatide following subcutaneous administration of a single dose of exenatide is 28 l.

Biotransformation and elimination

Nonclinical studies have shown that exenatide is predominantly eliminated by glomerular filtration with subsequent proteolytic degradation. The mean apparent clearance of exenatide is 9 l/h. These pharmacokinetic characteristics of exenatide are independent of the dose. Approximately 10 weeks after discontinuation of prolonged-release exenatide therapy, mean plasma exenatide concentrations fell below minimal detectable concentrations.

Special populations

Renal impairment

Population pharmacokinetic analysis of renal impaired patients receiving 2 mg prolonged-release exenatide indicate that there may be an increase in systemic exposure of approximately 74 % and 23 % (median prediction in each group) in moderate (N = 10) and mild (N = 56) renal impaired patients, respectively as compared to normal (N = 84) renal function patients.

Hepatic insufficiency

No pharmacokinetic study has been performed in patients with hepatic insufficiency. Exenatide is cleared primarily by the kidney, therefore hepatic dysfunction is not expected to affect blood concentrations of exenatide.

Gender, race and body weight

Gender, race and body weight have no clinically relevant influence on exenatide pharmacokinetics.

Elderly

Data in elderly are limited, but suggest no marked changes in exenatide exposure with increased age up to about 75 years old.

In a pharmacokinetic study of immediate-release exenatide in patients with type 2 diabetes, administration of exenatide (10 mcg) resulted in a mean increase of exenatide AUC by 36 % in 15 elderly subjects aged 75 to 85 years compared to 15 subjects aged 45 to 65 years likely related to reduced renal function in the older age group (see section 4.2).

Paediatric population

In a single-dose pharmacokinetic study of immediate-release exenatide in 13 patients with type 2 diabetes and between the ages of 12 and 16 years, administration of exenatide (5 mcg) resulted in slightly lower mean AUC (16 % lower) and C_{max} (25 % lower) compared to those observed in adults. No pharmacokinetics study of prolonged-release exenatide has been conducted in the paediatric population.

5.3 Preclinical safety data

Non-clinical data reveal no special hazards for humans based on conventional studies of safety pharmacology, repeat-dose toxicity, or genotoxicity conducted with immediate-release or prolonged-release exenatide.

Thyroid tumours have been observed in rats and mice with long acting GLP-1 receptor agonists. In a 2-year rat carcinogenicity study with prolonged-release exenatide, an increased incidence of C-cell adenomas and C-cell carcinomas was observed at doses ≥ 2 -fold the human systemic exposure based on AUC. The clinical relevance of these findings is currently unknown.

Animal studies with exenatide did not indicate harmful effects with respect to fertility; high doses of exenatide caused skeletal effects and reduced foetal and neonatal growth.

6. PHARMACEUTICAL PARTICULARS

6.1 List of excipients

Powder

poly (D,L-lactide-co-glycolide)
sucrose

Solvent

carmellose sodium
sodium chloride
polysorbate 20
sodium dihydrogen phosphate monohydrate
disodium phosphate heptahydrate
water for injections
sodium hydroxide (for pH adjustment)

6.2 Incompatibilities

In the absence of compatibility studies this medicinal product must not be mixed with other medicinal products.

6.3 Shelf life

3 years

After suspension

The suspension must be injected immediately after mixing the powder and the solvent.

6.4 Special precautions for storage

Store in a refrigerator (2°C - 8°C).

Do not freeze.

The pens may be kept for up to 4 weeks below 30°C prior to use. At the end of this period the pens must be used or discarded.

Store in the original package in order to protect from light.

For storage conditions after mixing of the medicinal product, see section 6.3.

6.5 Nature and contents of container

Each dual-chamber pen contains exenatide powder and solvent in a Type 1 glass cartridge sealed at one end with a chlorobutyl rubber stopper and an aluminium seal, and at the other end with a chlorobutyl rubber piston. The two chambers are separated by a second chlorobutyl rubber piston. There is one needle supplied per pen. Each carton also contains one spare needle. Use only the supplied needles with the pen.

Pack size of 4 single-dose pre-filled pens and a multipack containing 12 (3 packs of 4) single-dose pre-filled pens.

Not all pack sizes may be marketed.

6.6 Special precautions for disposal and other handling

Pre-filled pen is for single-use only.

The powder in one chamber must be mixed with the solvent in the other chamber of the pre-filled pen. The solvent should be visually inspected prior to use. The solvent should only be used if it is clear and free of particulate matter. After suspension, the mixture should only be used if it is white to off white

and cloudy. Please see the package leaflet and “Instructions for the User” for additional information on suspension and administration.

Use only the supplied custom needles with the pen.

Prolonged-release exenatide must be injected subcutaneously immediately after mixing of the powder and the solvent.

Prolonged-release exenatide that has been frozen must not be used.

The patient should be instructed to discard the pen safely, with the needle still attached, after each injection.

Any unused medicinal product or waste material should be disposed of in accordance with local requirements.

7. MARKETING AUTHORISATION HOLDER

AstraZeneca AB
SE-151 85 Södertälje
Sweden

8. MARKETING AUTHORISATION NUMBER(S)

EU/1/11/696/003-004

9. DATE OF FIRST AUTHORISATION/RENEWAL OF THE AUTHORISATION

Date of first authorisation: 17 June 2011
Date of latest renewal: 18 February 2016

10. DATE OF REVISION OF THE TEXT

Detailed information on this medicinal product is available on the website of the European Medicines Agency <http://www.ema.europa.eu>

1. NAME OF THE MEDICINAL PRODUCT

Bydureon 2 mg prolonged-release suspension for injection in pre-filled pen.

2. QUALITATIVE AND QUANTITATIVE COMPOSITION

Each pre-filled pen delivers a dose of 2 mg of exenatide in 0.85 ml.

For the full list of excipients, see section 6.1.

3. PHARMACEUTICAL FORM

Prolonged-release suspension for injection in pre-filled pen (BCise).

White to off-white opaque suspension.

4. CLINICAL PARTICULARS

4.1 Therapeutic indications

Bydureon is indicated in adults 18 years and older with type 2 diabetes mellitus to improve glycaemic control in combination with other glucose-lowering medicinal products including basal insulin, when the therapy in use, together with diet and exercise, does not provide adequate glycaemic control (see sections 4.4, 4.5 and 5.1 for available data on different combinations).

4.2 Posology and method of administration

Posology

The recommended dose is 2 mg exenatide once weekly.

Patients switching from immediate-release exenatide (Byetta) to prolonged-release exenatide (Bydureon or Bydureon BCise) may experience transient elevations in blood glucose concentrations, which generally improve within the first four weeks after initiation of therapy. Patients switching between the prolonged-release exenatide products (Bydureon or Bydureon BCise) may do so, with no expected relevant effect on blood glucose concentrations.

When prolonged-release exenatide is added to existing metformin and/or thiazolidinedione therapy, the current dose of metformin and/or thiazolidinedione can be continued. When added to sulphonylurea therapy, a reduction in the dose of sulphonylurea should be considered to reduce the risk of hypoglycaemia (see section 4.4).

Prolonged-release exenatide should be administered once a week on the same day each week. The day of weekly administration can be changed if necessary as long as the last dose was administered at least three days before. Prolonged-release exenatide can be administered at any time of day, with or without meals.

If a dose is missed, it should be administered as soon as practical, provided the next regularly scheduled dose is due in 3 days or more. Thereafter, patients can resume their usual once weekly dosing schedule.

If a dose is missed and the next regularly scheduled dose is due 1 or 2 days later, the patient should not administer the missed dose, but instead resume prolonged-release exenatide on the next regularly scheduled dosing day.

The use of this medicinal product does not require additional self-monitoring. Blood glucose self-monitoring may be necessary to adjust the dose of sulphonylurea.

If a different glucose-lowering treatment is started after the discontinuation of prolonged-release exenatide, consideration should be given to the prolonged release of the product (see section 5.2).

Special populations

Elderly

No dose adjustment is required based on age. However, as renal function generally declines with age, consideration should be given to the patient's renal function (see Renal impairment). The clinical experience in patients > 75 years is very limited (see section 5.2).

Renal impairment

No dose adjustment is necessary for patients with mild renal impairment (creatinine clearance 50 to 80 ml/min). Clinical experience in patients with moderate renal impairment (creatinine clearance 30 to 50 ml/min) is limited. Prolonged-release exenatide is not recommended in these patients.

Prolonged-release exenatide is not recommended for use in patients with end-stage renal disease or severe renal impairment (creatinine clearance <30 ml/min) (see section 4.4).

Hepatic impairment

No dose adjustment is necessary for patients with hepatic impairment (see section 5.2).

Paediatric population

The safety and efficacy of prolonged-release exenatide in children and adolescents aged under 18 years have not yet been established. Currently available data are described in section 5.2 but no recommendation on a posology can be made.

Method of administration

Subcutaneous use

Prolonged-release exenatide is for self-administration by the patient. Each pen can only be used by one person and is for single use.

Prior to initiation of prolonged-release exenatide, it is strongly recommended that patients and caregivers be trained by their healthcare professional. The "Instructions for the User", provided in the carton, must be followed carefully.

Each dose should be administered in the abdomen, thigh, or the back of the upper arm as a subcutaneous injection immediately after the medicinal product is fully mixed.

When used with insulin, prolonged-release exenatide and insulin must be administered as two separate injections.

For instructions on the preparation of the medicinal product before administration, see section 6.6 and the "Instructions for the User".

4.3 Contraindications

Hypersensitivity to the active substance or to any of the excipients listed in section 6.1.

4.4 Special warnings and precautions for use

Prolonged-release exenatide should not be used in patients with type 1 diabetes mellitus or for the treatment of diabetic ketoacidosis.

Prolonged-release exenatide must not be administered by intravenous or intramuscular injection.

Renal impairment

In patients with end stage renal disease receiving dialysis, single doses of immediate release exenatide increased frequency and severity of gastrointestinal adverse reactions; therefore, prolonged release exenatide formulations are not recommended for use in patients with end-stage renal disease or severe renal impairment (creatinine clearance <30 ml/min). The clinical experience in patients with moderate renal impairment is limited and the use of prolonged-release exenatide is not recommended.

There have been uncommon events of altered renal function with exenatide, including increased serum creatinine, renal impairment, worsened chronic renal failure and acute renal failure, sometimes requiring haemodialysis. Some of these events occurred in patients experiencing events that may affect hydration, including nausea, vomiting, and/or diarrhoea and/or receiving medicinal products known to affect renal function/hydration status. Concomitant medicinal products included angiotensin converting enzymes inhibitors, angiotensin-II antagonists, non-steroidal anti-inflammatory medicinal products and diuretics. Reversibility of altered renal function has been observed with supportive treatment and discontinuation of potentially causative medicinal products, including exenatide.

Severe gastrointestinal disease

Prolonged-release exenatide has not been studied in patients with severe gastrointestinal disease, including gastroparesis. Its use is commonly associated with gastrointestinal adverse reactions, including nausea, vomiting, and diarrhoea. Therefore, the use of this medicinal product is not recommended in patients with severe gastrointestinal disease.

Acute pancreatitis

Use of GLP-1 receptor agonists has been associated with a risk of developing acute pancreatitis. In clinical studies of Bydureon BCise, acute pancreatitis occurred in 0.4% of patients. There have been spontaneously reported events of acute pancreatitis with prolonged-release exenatide. Resolution of pancreatitis has been observed with supportive treatment, but very rare cases of necrotising or haemorrhagic pancreatitis and/or death have been reported. Patients should be informed of the characteristic symptom of acute pancreatitis: persistent, severe abdominal pain. If pancreatitis is suspected, the use of this medicinal product should be discontinued; if acute pancreatitis is confirmed, it should not be restarted. Caution should be exercised in patients with a history of pancreatitis.

Concomitant medicinal products

The concurrent use of prolonged-release exenatide formulations with D-phenylalanine derivatives (meglitinides), alpha-glucosidase inhibitors, dipeptidyl peptidase-4 inhibitors or other GLP-1 receptor agonists has not been studied. The concurrent use of a formulation of prolonged-release and immediate-release exenatide has not been studied and is not recommended.

Interaction with warfarin

There have been spontaneously reported cases of increased INR (International Normalized Ratio), sometimes associated with bleeding, with concomitant use of warfarin and exenatide (see section 4.5).

Hypoglycaemia

The risk of hypoglycaemia was increased when prolonged-release exenatide was used in combination with a sulphonylurea in clinical studies. Furthermore, in the clinical studies, patients on a sulphonylurea combination with mild renal impairment had an increased incidence of hypoglycaemia compared to patients with normal renal function. To reduce the risk of hypoglycaemia associated with the use of a sulphonylurea, reduction in the dose of sulphonylurea should be considered.

Rapid weight loss

Rapid weight loss at a rate of > 1.5 kg per week has been reported in patients treated with exenatide. Weight loss of this rate may have harmful consequences. Patients with rapid weight loss should be monitored for signs and symptoms of cholelithiasis.

Discontinuation of treatment

After discontinuation, the effect of prolonged-release exenatide may continue as plasma levels of exenatide decline over 10 weeks. Choice of other medicinal products and dose selection should be

considered accordingly, as adverse reactions may continue and efficacy may, at least partly, persist until exenatide levels decline.

4.5 Interaction with other medicinal products and other forms of interaction

Sulphonylureas

The dose of a sulphonylurea may require adjustment due to the increased risk of hypoglycaemia associated with sulphonylurea therapy (see sections 4.2 and 4.4).

Gastric emptying

The results of a study using paracetamol as a marker of gastric emptying suggest that the effect of prolonged-release exenatide to slow gastric emptying is minor and not expected to cause clinically significant reductions in the rate and extent of absorption of concomitantly administered oral medicinal products. Therefore, no dose adjustments for medicinal products sensitive to delayed gastric emptying are required.

When 1,000 mg paracetamol tablets were administered, either with or without a meal, following 14 weeks of prolonged-release exenatide therapy, no significant changes in paracetamol AUC were observed compared to the control period. Paracetamol C_{max} decreased by 16 % (fasting) and 5 % (fed) and t_{max} was increased from approximately 1 hour in the control period to 1.4 hours (fasting) and 1.3 hours (fed).

The following interaction studies have been conducted using 10 mcg immediate-release exenatide but not prolonged-release exenatide formulations:

Warfarin

A delay in t_{max} of about 2 h was observed when warfarin was administered 35 min after immediate-release exenatide. No clinically relevant effects on C_{max} or AUC were observed. Increased INR has been spontaneously reported during concomitant use of warfarin and prolonged-release exenatide. INR should be monitored during initiation of prolonged-release exenatide therapy in patients on warfarin and/or coumarin derivatives (see sections 4.4 and 4.8).

Hydroxy methyl glutaryl coenzyme A reductase inhibitors

Lovastatin AUC and C_{max} were decreased approximately 40 % and 28 %, respectively, and t_{max} was delayed about 4 h when immediate-release exenatide was administered concomitantly with a single dose of lovastatin (40 mg) compared with lovastatin administered alone. In 30-week placebo-controlled clinical studies with immediate-release exenatide, concomitant use of exenatide and HMG CoA reductase inhibitors was not associated with consistent changes in lipid profiles (see section 5.1). No predetermined dose adjustment is required; however, lipid profiles should be monitored as appropriate.

Digoxin and lisinopril

In interaction studies of the effect of immediate-release exenatide on digoxin and lisinopril there were no clinically relevant effects on C_{max} or AUC, however, a delay in t_{max} of about 2 h was observed.

Ethinyl estradiol and levonorgestrel

Administration of a combination oral contraceptive (30 mcg ethinyl estradiol plus 150 mcg levonorgestrel) one hour before immediate-release exenatide did not alter the AUC, C_{max} or C_{min} of either ethinyl estradiol or levonorgestrel. Administration of the oral contraceptive 35 minutes after exenatide did not affect AUC but resulted in a reduction of the C_{max} of ethinyl estradiol by 45 %, and C_{max} of levonorgestrel by 27-41 %, and a delay in t_{max} by 2-4 h due to delayed gastric emptying. The reduction in C_{max} is of limited clinical relevance and no adjustment of dosing of oral contraceptives is required.

Paediatric population

Interaction studies with exenatide have only been performed in adults.

4.6 Fertility, pregnancy and lactation

Women of childbearing potential

Due to the long washout period of prolonged-release exenatide, women of childbearing potential should use contraception during treatment with prolonged-release exenatide. This medicine should be discontinued at least 3 months before a planned pregnancy.

Pregnancy

There are no adequate data from the use of prolonged-release exenatide in pregnant women. Studies in animals have shown reproductive toxicity (see section 5.3). The potential risk for humans is unknown. Prolonged-release exenatide should not be used during pregnancy and the use of insulin is recommended.

Breast-feeding

It is unknown whether exenatide is excreted in human milk. Prolonged-release exenatide should not be used during breast-feeding.

Fertility

No fertility studies in humans have been conducted.

4.7 Effects on ability to drive and use machines

Prolonged-release exenatide has minor influence on the ability to drive and use machines. When used in combination with a sulphonylurea, patients should be advised to take precautions to avoid hypoglycaemia while driving and using machines.

4.8 Undesirable effects

Summary of the safety profile

The most frequent adverse reactions during the clinical studies were gastrointestinal-related (mainly nausea (8 %), which tended to dissipate with continued treatment), headache (4 %) and injection site reactions, such as injection site pruritus (3 %) and injection site erythema (2 %). In addition, hypoglycaemia with a sulphonylurea occurred very commonly (see Description of selected adverse reactions, below). Most adverse reactions were mild to moderate in intensity.

Tabulated list of adverse reactions

The frequency of adverse reactions of Bydureon BCise identified from clinical studies are summarised in Table 1 below.

The pooled clinical studies data set for Bydureon BCise comprises two phase 3 comparator-controlled studies of 6 to 12 months duration. The follow-up and extension phases of studies are included in the pool. Background therapies included diet and exercise alone or with metformin, a sulphonylurea, a thiazolidinedione or a combination of oral glucose-lowering medicinal products. Adverse reactions that have been observed with the prolonged-release exenatide but not in clinical studies with Bydureon BCise are also included in Table 1.

Background therapies in the prolonged-release exenatide clinical trials included diet and exercise, metformin, a sulphonylurea, a thiazolidinedione, a combination of oral glucose-lowering agents or a basal insulin.

The reactions are listed below as MedDRA preferred term by system organ class and absolute frequency. Frequencies are defined as: very common ($\geq 1/10$), common ($\geq 1/100$ to $< 1/10$), uncommon ($\geq 1/1,000$ to $< 1/100$), rare ($\geq 1/10,000$ to $< 1/1,000$) very rare ($< 1/10,000$) and not known (cannot be estimated from the available data).

Table 1: Adverse reactions of Bydureon BCise identified from clinical studies

System organ class /adverse reaction terms	Frequency of occurrence ¹					
	Very common	Common	Uncommon	Rare	Very rare	Not known
Immune system disorders						
Anaphylactic reaction ²				X		
Metabolism and nutrition disorders						
Hypoglycaemia (with a sulphonylurea) ^{5,6,7}	X					
Hypoglycaemia (without a sulphonylurea) ^{5,6,7}			X			
Hypoglycaemia (with insulin) ^{3,4,5}		X				
Decreased appetite			X			
Dehydration			X			
Nervous system disorders						
Headache		X				
Dizziness		X				
Dysgeusia			X			
Somnolence ²			X			
Gastrointestinal disorders						
Nausea ⁵		X				
Diarrhoea		X				
Vomiting		X				
Constipation		X				
Dyspepsia		X				
Gastroesophageal reflux disease		X				
Abdominal distension		X				
Abdominal pain		X				
Flatulence			X			
Acute pancreatitis (see section 4.4)			X			
Eructation ²			X			
Intestinal obstruction ²			X			
Skin and subcutaneous tissue disorders						
Urticaria			X			
Hyperhidrosis			X			
Macular or papular rash			X			
Pruritus			X			
Alopecia ²			X			
Angioedema ⁹						X
Injection site abscesses and cellulitis ⁹						X
Renal and urinary disorders						
Altered renal function ⁸			X			

System organ class /adverse reaction terms	Frequency of occurrence ¹					
	Very common	Common	Uncommon	Rare	Very rare	Not known
General disorders and administration site conditions						
Injection site pruritus ⁵		X				
Injection site erythema ⁵		X				
Fatigue		X				
Injection site reaction ⁵			X			
Asthenia			X			
Injection site rash ⁵			X			
Feeling jittery ²				X		
Investigations						
International normalised ratio increased ⁹ (see section 4.4)						X

¹ Rate based on completed long-term safety and efficacy studies (n = 526), unless other indicated. Includes follow-up within seventy days of the last dose received and extension period.

² Rate based on twelve prolonged-release exenatide completed long-term efficacy and safety studies n = 2868 total.

³ Based on hypoglycaemic events that 1. Result in loss of consciousness, seizure, or coma which resolves after administration of glucagon or glucose OR 2. Require third-party assistance to resolve because of impairment in consciousness or behaviour and has glucose value of <54 mg/dL (3 mmol/L) OR 3. Result in symptoms consistent with hypoglycaemia with a concomitant glucose <54 mg/dL (3 mmol/L) prior to treatment.

⁴ Frequency reported from the 28-week controlled treatment period of the prolonged-release exenatide as add on to insulin glargine study (N=232).

⁵ See Description of selected adverse reactions section, below.

⁶ Frequencies reported in pooled data from the controlled periods of the two phase 3 clinical studies (n = 410).

⁷ Based on hypoglycaemic events that have symptoms consistent with hypoglycaemia with a concomitant glucose value of <54 mg/dl (3 mmol/l) prior to treatment.

⁸ Includes acute renal failure, worsened chronic renal failure, renal impairment, increased serum creatinine. See section 4.4.

⁹ Rate based on prolonged-release exenatide spontaneous reports data (unknown denominator).

Description of selected adverse reactions

Hypoglycaemia

There were no events of major hypoglycaemia with Bydureon BCise. The overall incidence of minor hypoglycaemia was 6.3 %. This incidence was increased when it was used in combination with a sulphonylurea (26.1 %) compared to no sulphonylurea (0.9 %) (see section 4.4). To reduce the risk of hypoglycaemia associated with the use of a sulphonylurea, reduction in the dose of sulphonylurea may be considered (see sections 4.2 and 4.4).

When prolonged-release exenatide was added to basal insulin, no initial dose adjustment of insulin was required. Prolonged-release exenatide in combination with basal insulin showed no clinically significant differences in the incidence of hypoglycaemic episodes compared to insulin. There were no episodes of major hypoglycaemia in the prolonged-release exenatide with insulin group.

Nausea

The most frequently reported gastrointestinal adverse reaction was nausea. During the controlled period of the clinical study comparing Bydureon BCise with immediate-release exenatide, nausea was

reported in 9.6 % and 20.5 % of patients in each group. Overall, 9.3 % of patients treated with Bydureon BCise reported nausea during the controlled period of both clinical studies. Most episodes of nausea were mild to moderate, associated with the initiation of treatment and decreased over time.

Injection site reactions

During the controlled period of the clinical studies, injection site reactions were observed more frequently in patients treated with Bydureon BCise versus comparator-treated patients (24 % versus 4 % with immediate-release exenatide). These injection site reactions were generally mild and usually did not lead to discontinuation of study medication. Patients may be treated to relieve symptoms, while continuing treatment. Subsequent injections should use a different site of injection each week. In postmarketing experience with prolonged-release exenatide, cases with injection site abscesses and cellulitis have been reported.

Subcutaneous injection site nodules were observed frequently in clinical studies, consistent with the known properties of poly (D,L-lactide co-glycolide) polymer microsphere formulations. Most individual nodules did not interfere with study participation and resolved over time.

Immunogenicity

Consistent with the potentially immunogenic properties of protein and peptide pharmaceuticals, patients may develop antibodies to exenatide following treatment with prolonged-release exenatide.

Approximately 42 % of patients developed low titre antibodies to exenatide and 32 % of patients developed high titre antibodies at any time during the studies. The percentage of these subjects with positive antibody titres, in particular high titres, peaked at approximately weeks 8 to 16 of dosing and then diminished over time. At the study endpoint, approximately 43 % of patients had low titre antibodies to exenatide and 14 % of patients had high titre antibodies. Overall, the level of glycaemic control (HbA_{1c}) in patients treated with Bydureon BCise with low titre antibodies at the last visit (-1.1 % to -1.5 %) was comparable to that observed in those without antibody titres (-1.1 % to -1.4 %). While patients with high titre antibodies at the last visit had an attenuated HbA_{1c} response, HbA_{1c} reductions in these patients were clinically relevant (-0.6 % to -0.7 %).

Amongst patients treated with Bydureon BCise evaluable for antibodies (N = 393), the incidence of potentially immunogenic injection site reactions (most commonly injection site nodule) during the two studies was approximately 20 %. These reactions were less commonly observed in antibody-negative patients (16 %) and patients with low titre antibodies (16 %) compared with those with high titre antibodies (27 %).

Rapid weight loss

In a 30-week study, approximately 3 % (n = 4/148) of prolonged-release exenatide treated patients experienced at least one time period of rapid weight loss (recorded body weight loss between two consecutive study visits of greater than 1.5 kg/week).

Increased heart rate

A mean increase in heart rate (HR) of 2.4 beats per minute (bpm) from baseline (74 bpm) was observed in the controlled period of the Bydureon BCise clinical studies. Fifteen percent of prolonged-release exenatide treated patients had mean increases in HR of ≥ 10 bpm; approximately 5 % to 10 % of subjects within the other treatment groups had mean increases in HR of ≥ 10 bpm.

Reporting of suspected adverse reactions

Reporting suspected adverse reactions after authorisation of the medicinal product is important. It allows continued monitoring of the benefit/risk balance of the medicinal product. Healthcare professionals are asked to report any suspected adverse reactions via the national reporting system listed in [Appendix V](#).

4.9 Overdose

Effects of overdoses with exenatide (based on immediate-release exenatide clinical studies) included severe nausea, severe vomiting and rapidly declining blood glucose concentrations. In the event of overdose, appropriate supportive treatment should be initiated according to the patient's clinical signs and symptoms.

5. PHARMACOLOGICAL PROPERTIES

5.1 Pharmacodynamic properties

Pharmacotherapeutic group: Drugs used in diabetes, glucagon-like peptide-1 (GLP-1) analogues, ATC code: A10BJ01.

Mechanism of action

Exenatide is a glucagon-like peptide-1 (GLP-1) receptor agonist that exhibits several antihyperglycaemic actions of glucagon-like peptide-1 (GLP-1). The amino acid sequence of exenatide partially overlaps that of human GLP-1. Exenatide has been shown to bind to and activate the known human GLP-1 receptor *in vitro*, its mechanism of action mediated by cyclic AMP and/or other intracellular signalling pathways.

Exenatide increases, on a glucose-dependent basis, the secretion of insulin from pancreatic beta cells. As blood glucose concentrations decrease, insulin secretion subsides. When exenatide was used in combination with metformin and/or a thiazolidinedione, no increase in the incidence of hypoglycaemia was observed over that of placebo in combination with metformin and/or a thiazolidinedione which may be due to this glucose-dependent insulinotropic mechanism (see section 4.4).

Exenatide suppresses glucagon secretion which is known to be inappropriately elevated in patients with type 2 diabetes. Lower glucagon concentrations lead to decreased hepatic glucose output. However, exenatide does not impair the normal glucagon response and other hormone responses to hypoglycaemia.

Exenatide slows gastric emptying, thereby reducing the rate at which meal-derived glucose appears in the circulation.

Administration of exenatide has been shown to reduce food intake, due to decreased appetite and increased satiety.

Pharmacodynamic effects

Exenatide improves glycaemic control through the sustained effects of lowering both postprandial and fasting glucose concentrations in patients with type 2 diabetes. Unlike native GLP-1, prolonged-release exenatide has a pharmacokinetic and pharmacodynamic profile in humans suitable for once weekly administration.

A pharmacodynamic study with exenatide demonstrated in patients with type 2 diabetes (n = 13) a restoration of first phase insulin secretion and improved second phase insulin secretion in response to an intravenous bolus of glucose.

Clinical efficacy and safety

The results of two studies with Bydureon BCise and six long-term clinical studies of prolonged-release exenatide are presented below; these studies comprised 1766 subjects (556 treated with Bydureon BCise), 53 % men and 47 % women, 304 subjects (17 %) were \geq 65 years of age.

Glycaemic control

Bydureon BCise

In a 28-week open-label study, Bydureon BCise was compared to immediate-release exenatide in subjects on a diet and exercise programme alone or with a stable regimen of oral glucose-lowering medicinal products. Both treatment groups had a reduction in HbA_{1c} compared to baseline. Bydureon BCise demonstrated superiority to immediate-release exenatide in reducing HbA_{1c} from baseline to Week 28 (Table 2). The 28-week comparator-controlled period of the study was followed by a 24-week extension period during which all participating subjects received treatment with this medicinal product. The effect on HbA_{1c} remained clinically significant over 52 weeks but partially diminished over time in the group that had initially received Bydureon BCise.

Both Bydureon BCise and immediate-release exenatide patients achieved a reduction in weight at Week 28 compared to baseline (Table 2). The difference between the two treatment groups was not significant. The reductions in body weight were sustained at Week 52.

Table 2: Results of one 28-week study of Bydureon BCise versus immediate-release exenatide with diet and exercise alone or with a stable regimen of oral glucose-lowering medicinal products (modified intent to treat patients¹)

	Bydureon BCise 2 mg QW	Immediate-release exenatide 10 mcg BID
N	229	146
Mean HbA_{1c} (%)		
Baseline	8.5	8.5
Change from baseline (\pm SE) ²	-1.4 (\pm 0.1)	-1.0 (\pm 0.1)
Mean difference in change from baseline versus immediate-release exenatide (95 % CI)²	-0.37* (-0.63, -0.10)	
Patients (%) achieving HbA_{1c} < 7 %³	49	43
Mean body weight (kg)		
Baseline	97	97
Change from baseline (\pm SE) ²	-1.5 (\pm 0.3)	-1.9 (\pm 0.4)
Mean difference in change from baseline versus immediate-release exenatide (95 % CI)²	+0.40 (-0.48, 1.28)	
Mean change from baseline in fasting plasma glucose (mmol/l) (\pm SE)²	-1.8 (\pm 0.2)	-1.3 (\pm 0.3)
Mean difference in change from baseline versus immediate-release exenatide (95 % CI)²	-0.56 (-1.20, 0.08)	

QW = once weekly, BID = twice daily, N = number of patients per treatment group, SE = standard error, CI = confidence interval.

*p-value < 0.01.

¹ All randomised patients who received at least one dose of study medication.

² Least squares means.

³ Last Observation Carried Forward (LOCF).

In a 28-week open-label study (oral medication-blinded), Bydureon BCise was compared to sitagliptin and placebo in subjects also using metformin \geq 1,500 mg daily. Bydureon BCise demonstrated superiority to both sitagliptin and placebo in reducing HbA_{1c} from baseline to Week 28 (Table 3).

Both Bydureon BCise and sitagliptin patients achieved a reduction in weight at Week 28 compared to baseline (Table 3). The difference between the two treatment groups was not significant.

Table 3: Results of one 28-week study of Bydureon BCise versus sitagliptin and placebo in combination with metformin (modified intent to treat patients¹)

	Bydureon BCise2 mg QW	Sitagliptin 100 mg QD	Placebo QD
N	181	122	61
Mean HbA_{1c} (%)			
Baseline	8.4	8.5	8.5
Change from baseline (\pm SE) ²	-1.1 (\pm 0.1)	-0.8 (\pm 0.1)	-0.4 (\pm 0.2)
Mean difference in change from baseline versus sitagliptin (95 % CI)²	-0.38* (-0.70, -0.06)		
Mean difference in change from baseline versus placebo (95 % CI)²	-0.72** (-1.15, -0.30)		
Patients (%) achieving HbA_{1c} < 7 %³	43*	32	25
Mean body weight (kg)			
Baseline	89	88	89
Change from baseline (\pm SE) ²	-1.1 (\pm 0.3)	-1.2 (\pm 0.3)	+0.2 (\pm 0.5)
Mean difference in change from baseline versus sitagliptin (95 % CI)²	+0.07 (-0.73, 0.87)		
Mean difference in change from baseline versus placebo (95 % CI)²	-1.27# (-2.34, -0.20)		
Mean change from baseline in fasting plasma glucose (mmol/l) (\pm SE)²	-1.2 (\pm 0.2)	-0.6 (\pm 0.3)	+0.5 (\pm 0.4)
Mean difference in change from baseline versus sitagliptin (95 % CI)²	-0.56 (-1.21, 0.09)		
Mean difference in change from baseline versus placebo (95 % CI)²	-1.71§ (-2.59, -0.83)		

QW = once weekly, QD = once daily, N = number of patients per treatment group, SE = standard error, CI = confidence interval.

*p-value < 0.05, **p-value < 0.01, #nominal p-value < 0.05, §nominal p-value < 0.001.

¹ All randomised patients who received at least one dose of study medication.

² Least squares means.

³ Last Observation Carried Forward (LOCF).

Prolonged-release exenatide

In two studies prolonged-release exenatide 2 mg once weekly has been compared to immediate-release exenatide 5 mcg given twice daily for 4 weeks followed by immediate-release exenatide 10 mcg given twice daily. One study was of 24 weeks in duration (n = 252) and the other of 30 weeks (n = 295) followed by an open labelled extension where all patients were treated with prolonged-release exenatide 2 mg once weekly, for a further 7 years (n = 258). In both studies, decreases in HbA_{1c} were evident in both treatment groups as early as the first post-treatment HbA_{1c} measurement (Weeks 4 or 6).

Prolonged-release exenatide resulted in a statistically significant reduction in HbA_{1c} compared to patients receiving immediate-release exenatide (Table 4).

A clinically relevant effect of prolonged-release exenatide and immediate-release exenatide treated subjects was observed on HbA_{1c}, regardless of the background anti-diabetic therapy in both studies.

Clinically and statistically significantly more subjects on prolonged-release compared to immediate-release exenatide patients achieved an HbA_{1c} reduction of \leq 7 % or < 7 % in the two studies (p < 0.05 and p \leq 0.0001 respectively).

Both prolonged-release and immediate-release exenatide patients achieved a reduction in weight compared to baseline, although the difference between the two treatment arms was not significant.

In the uncontrolled study extension, evaluable patients who switched from immediate release to prolonged-release exenatide at week 30 (n = 121), achieved the same improvement in HbA_{1c} of -2.0 % at Week 52 compared to baseline as patients treated with prolonged-release exenatide.

For all patients completing the uncontrolled study extension of 7 years (n = 122 of 258 patients included in the extension phase), HbA_{1c} gradually increased over time from week 52 onwards, but was still reduced compared to baseline after 7 years (-1.5%). Weight loss was sustained over 7 years in these patients.

Table 4: Results of two studies of prolonged-release versus immediate-release exenatide in combination with diet and exercise alone, metformin and/or sulphonylurea and metformin and/or thiazolidinedione (intent to treat patients)

24-Week Study	Prolonged-release exenatide 2 mg	Immediate-release exenatide 10 mcg twice daily
N	129	123
Mean HbA_{1c} (%)		
Baseline	8.5	8.4
Change from baseline (± SE)	-1.6 (±0.1)**	-0.9 (±0.1)
Mean difference change from baseline between treatments (95 % CI)	-0.67 (-0.94, -0.39)**	
Patients (%) achieving HbA_{1c} < 7 %	58	30
Change in fasting plasma glucose (mmol/l) (± SE)	-1.4 (±0.2)	-0.3 (±0.2)
Mean body weight (kg)		
Baseline	97	94
Change from baseline (± SE)	-2.3 (±0.4)	-1.4 (± 0.4)
Mean difference change from baseline between treatments (95 % CI)	-0.95 (-1.91, 0.01)	
30-Week Study		
N	148	147
Mean HbA_{1c} (%)		
Baseline	8.3	8.3
Change from baseline (± SE)	-1.9 (±0.1)*	-1.5 (±0.1)
Mean difference change from baseline between treatments (95 % CI)	-0.33 (-0.54, -0.12)*	
Patients (%) achieving HbA_{1c} ≤ 7 %	73	57
Change in fasting plasma glucose (mmol/l) (± SE)	-2.3 (±0.2)	-1.4 (±0.2)
Mean body weight (kg)		
Baseline	102	102
Change from baseline (± SE)	-3.7 (±0.5)	-3.6 (±0.5)
Mean difference change from baseline between treatments (95 % CI)	-0.08 (-1.29, 1.12)	

SE = standard error, CI = confidence interval, * p < 0.05, **p < 0.0001

A study of 26-week duration has been conducted, in which prolonged-release exenatide 2 mg is compared to insulin glargine once daily. Compared with insulin glargine treatment, prolonged-release exenatide demonstrated a superior change in HbA_{1c}, significantly lowered mean body weight and was associated with fewer hypoglycaemic events (Table 5).

Table 5: Results of one 26-week study of prolonged-release exenatide versus insulin glargine in combination with metformin alone or metformin and sulphonylurea (intent to treat patients)

	Prolonged-release exenatide 2 mg	Insulin glargine¹
N	233	223
Mean HbA_{1c} (%)		
Baseline	8.3	8.3
Change from baseline (± SE)	-1.5 (± 0.1)*	-1.3 (± 0.1)*
Mean difference change from baseline between treatments (95 % CI)	-0.16 (-0.29, -0.03)*	
Patients (%) achieving HbA_{1c} ≤ 7 %	62	54
Change in fasting serum glucose (mmol/l) (± SE)	-2.1 (± 0.2)	-2.8 (± 0.2)
Mean body weight (kg)		
Baseline	91	91
Change from baseline (± SE)	-2.6 (± 0.2)	+1.4 (± 0.2)
Mean difference change from baseline between treatments (95 % CI)	-4.05 (-4.57, -3.52)*	

SE = standard error, CI = confidence interval, * p < 0.05

¹ Insulin glargine was dosed to a target glucose concentration of 4.0 to 5.5 mmol/l (72 to 100 mg/dl). The mean dose of insulin glargine at the beginning of treatment was 10.1 IU/day rising to 31.1 IU/day for insulin glargine-treated patients.

The 156-week results were consistent with those previously reported in the 26-week interim report. Treatment with prolonged-release exenatide persistently significantly improved glycaemic control and weight control, compared to the insulin glargine treatment. Safety findings at 156 weeks were consistent with those reported at 26 weeks.

In a 26-week double-blind study prolonged-release exenatide was compared to maximum daily doses of sitagliptin and pioglitazone in subjects also using metformin. All treatment groups had a significant reduction in HbA_{1c} compared to baseline. Prolonged-release exenatide demonstrated superiority to both sitagliptin and pioglitazone with respect to change in HbA_{1c} from baseline.

Prolonged-release exenatide demonstrated significantly greater weight reductions compared to sitagliptin. Patients on pioglitazone gained weight (Table 6).

Table 6: Results of one 26-week study of prolonged-release exenatide versus sitagliptin and versus pioglitazone in combination with metformin (intent to treat patients)

	Prolonged-release exenatide 2 mg	Sitagliptin 100 mg	Pioglitazone 45 mg
N	160	166	165
Mean HbA_{1c} (%)			
Baseline	8.6	8.5	8.5
Change from baseline (± SE)	-1.6 (± 0.1)*	-0.9 (± 0.1)*	-1.2 (± 0.1)*
Mean difference change from baseline between treatments (95 % CI) versus sitagliptin	-0.63 (-0.89, -0.37)**		
Mean difference change from baseline between treatments (95 % CI) versus pioglitazone	-0.32 (-0.57, -0.06)*		
Patients (%) achieving HbA_{1c} ≤ 7 %	62	36	49
Change in fasting serum glucose (mmol/l) (± SE)	-1.8 (± 0.2)	-0.9 (± 0.2)	-1.5 (± 0.2)
Mean body weight (kg)			
Baseline	89	87	88
Change from baseline (± SE)	-2.3 (± 0.3)	-0.8 (± 0.3)	+2.8 (± 0.3)
Mean difference change from baseline between treatments (95 % CI) versus sitagliptin	-1.54 (-2.35, -0.72)*		
Mean difference change from baseline between treatments (95 % CI) versus pioglitazone	-5.10 (-5.91, -4.28)**		

SE = standard error, CI = confidence interval, *p <0.05, **p <0.0001

In a 28-week, double-blind study, the combination of prolonged-release exenatide and dapagliflozin was compared to prolonged-release exenatide alone and dapagliflozin alone in subjects also using metformin. All treatment groups had a reduction in HbA_{1c} compared to baseline. The prolonged-release exenatide and dapagliflozin treatment group showed superior reductions in HbA_{1c} from baseline compared to prolonged-release exenatide alone and dapagliflozin alone (Table 7).

The combination of prolonged-release exenatide and dapagliflozin demonstrated significantly greater weight reductions compared to either medicinal product alone (Table 7).

Table 7: Results of one 28-week study of prolonged-release exenatide and dapagliflozin versus prolonged-release exenatide alone and dapagliflozin alone, in combination with metformin (intent to treat patients)

	Prolonged-release exenatide 2 mg QW + Dapagliflozin 10 mg QD	Prolonged-release exenatide 2 mg QW + Placebo QD	Dapagliflozin 10 mg QD + Placebo QW
N	228	227	230
Mean HbA_{1c} (%)			
Baseline	9.3	9.3	9.3
Change from baseline (±SE) ^a	-2.0 (±0.1)	-1.6 (±0.1)	-1.4 (±0.1)
Mean difference in change from baseline between combination and single active medicinal product (95 % CI)		-0.38* (-0.63, -0.13)	-0.59** (-0.84, -0.34)
Patients (%) achieving HbA_{1c} < 7 %	45	27	19
Mean change from baseline in fasting plasma glucose (mmol/l) (±SE)^a			
Baseline	-3.7 (±0.2)	-2.5 (±0.2)	-2.7 (±0.2)
Mean difference in change from baseline between combination and single active medicinal product (95 % CI)		-1.12** (-1.55, -0.68)	-0.92** (-1.36, -0.49)
Mean change from baseline in 2-hour postprandial plasma glucose (mmol/l) (±SE)^a			
Baseline	-4.9 (±0.2)	-3.3 (±0.2)	-3.4 (±0.2)
Mean difference in change from baseline between combination and single active medicinal product (95 % CI)		-1.54** (-2.10, -0.98)	-1.49** (-2.04, -0.93)
Mean body weight (kg)			
Baseline	92	89	91
Change from baseline (±SE) ^a	-3.6 (±0.3)	-1.6 (±0.3)	-2.2 (±0.3)
Mean difference in change from baseline between combination and single active medicinal product (95 % CI)		-2.00** (-2.79, -1.20)	-1.33** (-2.12, -0.55)

QW=once weekly, QD=once daily, SE = standard error, CI= confidence interval, N=number of patients.

^a Adjusted least squares means (LS Means) and treatment group difference(s) in the change from baseline values at Week 28 are modelled using a mixed model with repeated measures (MMRM) including treatment, region, baseline HbA_{1c} stratum (< 9.0 % or ≥ 9.0 %), week, and treatment by week interaction as fixed factors, and baseline value as a covariate.

*p < 0.01, **p < 0.001.

p-values are all adjusted p-values for multiplicity.

Analyses exclude measurements post rescue therapy and post premature discontinuation of study medicinal product.

In a 28-week double-blind study, prolonged-release exenatide added to insulin glargine alone or with metformin was compared to placebo added to insulin glargine alone or with metformin. Insulin glargine was dosed targeting a fasting plasma glucose of 4.0 to 5.5 mmol/l (72 to 99 mg/dl). Prolonged-release exenatide demonstrated superiority to placebo in reducing HbA_{1c} from baseline to Week 28 (Table 8).

Prolonged-release exenatide was superior to placebo in reducing body weight at Week 28 (Table 8).

Table 8: Results of one 28-week study of prolonged-release exenatide versus placebo in combination with insulin glargine alone or with metformin (intent to treat patients)

	Prolonged-release exenatide 2 mg + Insulin glargine^a	Placebo + Insulin glargine^a
N	231	230
Mean HbA_{1c} (%)		
Baseline	8.5	8.5
Change from baseline (± SE) ^b	-1.0 (±0.1)	-0.2 (±0.1)
Mean difference in change from baseline between treatments (95% CI)	-0.73* (-0.93, -0.53)	
Patients (%) achieving HbA_{1c} ≤7%^c	33*	7
Mean body weight (kg)		
Baseline	94	94
Change from baseline (± SE) ^b	-1.0 (±0.3)	0.5 (±0.3)
Mean difference in change from baseline between treatments (95% CI)	-1.50* (-2.17, -0.84)	
Change from baseline in 2-hour postprandial plasma glucose (mmol/l) (± SE)^{b,d}	-1.6 (±0.3)	-0.1 (±0.3)
Mean difference in change from baseline between treatments (95% CI)	-1.52* (-2.15, -0.90)	

N=number of patients in each treatment group, SE = standard error, CI= confidence interval, *p-value <0.001 (adjusted for multiplicity).

^a. The LS means change in mean daily insulin dose was 1.6 units for the prolonged-release exenatide group and 3.6 units for the placebo group.

^b. Adjusted LS means and treatment group difference(s) in the change from baseline values at Week 28 are modeled using a mixed model with repeated measures (MMRM) including treatment, region, baseline HbA_{1c} stratum (<9.0% or ≥9.0%), baseline SU-use stratum (yes vs. no), week, and treatment by week interaction as fixed factors, and baseline value as a covariate. The absolute change in 2-hour postprandial plasma glucose at Week 28 is modeled similarly using ANCOVA.

^c. All patients with missing endpoint data are imputed as non-responders.

^d. After a standard meal tolerance test.

Analyses exclude measurements post rescue therapy and post premature discontinuation of study medication.

Body weight

A reduction in body weight compared to baseline has been observed in studies with prolonged-release exenatide formulations. This reduction in body weight was seen irrespective of the occurrence of nausea although the reduction was larger in the group with nausea (mean reduction of -1.9 kg to -5.2 kg with nausea versus -1.0 kg to -2.9 kg without nausea).

Plasma/serum glucose

Treatment with prolonged-release exenatide resulted in significant reductions in fasting plasma/serum glucose concentrations, these reductions were observed as early as 4 weeks. In the placebo-controlled study with insulin glargine, the change from baseline to Week 28 in fasting plasma glucose was -0.7 mmol/l for the prolonged-release exenatide group and -0.1 mmol/l for the placebo group. Additional reductions in postprandial concentrations were also observed. For both prolonged-release exenatide formulations, the improvement in fasting plasma glucose concentrations was sustained through 52 weeks.

Beta-cell function

Clinical studies with prolonged-release exenatide formulations have indicated improved beta-cell function, using measures such as the homeostasis model assessments (HOMA-B). The effect on beta-cell function was sustained through 52 weeks.

Blood pressure

A reduction in systolic blood pressure was observed in the studies with prolonged-release exenatide formulations (0.8 mmHg to 4.7 mmHg). In the 30-week immediate-release exenatide comparator study both prolonged-release and immediate-release exenatide significantly reduced systolic blood pressure from baseline (4.7 ± 1.1 mmHg and 3.4 ± 1.1 mmHg respectively) the difference between the treatments was not significant. Improvements in blood pressure were maintained through 52 weeks.

In the placebo-controlled study with insulin glargine, the change from baseline to Week 28 in systolic blood pressure was -2.6 mmHg for the prolonged-release exenatide group and -0.7 mmHg for the placebo group.

Treatment with prolonged-release exenatide and dapagliflozin combination at Week 28 resulted in a significant mean change reduction of -4.3 ± 0.8 mmHg in systolic blood pressure compared to prolonged-release exenatide alone of -1.2 ± 0.8 mmHg ($p < 0.01$) or to dapagliflozin alone of -1.8 ± 0.8 mmHg ($p < 0.05$).

Fasting lipids

The prolonged-release exenatide formulations have shown no negative effects on lipid parameters.

Paediatric population

The European Medicines Agency has deferred the obligation to submit the results of studies with prolonged-release exenatide formulations in one or more subsets of the paediatric population in type 2 diabetes mellitus (see section 4.2 for information on paediatric use).

5.2 Pharmacokinetic properties

The absorption properties of exenatide reflect the extended release properties of the prolonged-release exenatide formulation. Once absorbed into the circulation, exenatide is distributed and eliminated according to its known systemic pharmacokinetic properties (as described in this section).

Absorption

Following weekly administration of 2 mg Bydureon BCise, mean exenatide concentrations exceeded minimal efficacious concentrations (~ 50 pg/ml) in 2 weeks with gradual increase in the average plasma exenatide concentration up to Week 8. Subsequently, exenatide concentrations of approximately 153-208 pg/ml were maintained, indicating that steady state was achieved. Steady-state exenatide concentrations are maintained during the one-week interval between doses with minimal peak to trough fluctuation from this average therapeutic concentration.

Distribution

The mean apparent volume of distribution of exenatide following subcutaneous administration of a single dose of exenatide is 28 l.

Biotransformation and elimination

Nonclinical studies have shown that exenatide is predominantly eliminated by glomerular filtration with subsequent proteolytic degradation. The mean apparent clearance of exenatide is 9 l/h. These pharmacokinetic characteristics of exenatide are independent of the dose. Approximately 10 weeks after discontinuation of prolonged-release exenatide therapy, mean plasma exenatide concentrations fell below minimal detectable concentrations.

Special populations

Renal impairment

No clinically meaningful differences were observed in steady state exenatide concentrations or tolerability in patients with mild to moderate renal impairment (eGFR 30 to 89 ml/min/1.73m²) receiving Bydureon BCise, compared to those with normal renal function.

Hepatic insufficiency

No pharmacokinetic study has been performed in patients with hepatic insufficiency. Exenatide is cleared primarily by the kidney; therefore hepatic dysfunction is not expected to affect blood concentrations of exenatide.

Gender, race and body weight

Gender, race and body weight have no clinically relevant influence on exenatide pharmacokinetics.

Elderly

Data in elderly are limited, but suggest no marked changes in exenatide exposure with increased age up to about 75 years old.

In a pharmacokinetic study of immediate-release exenatide in patients with type 2 diabetes, administration of exenatide (10 mcg) resulted in a mean increase of exenatide AUC by 36 % in 15 elderly subjects aged 75 to 85 years compared to 15 subjects aged 45 to 65 years likely related to reduced renal function in the older age group (see section 4.2).

Paediatric population

In a single-dose pharmacokinetic study of immediate-release exenatide in 13 patients with type 2 diabetes and between the ages of 12 and 16 years, administration of exenatide (5 mcg) resulted in slightly lower mean AUC (16 % lower) and C_{max} (25 % lower) compared to those observed in adults. No pharmacokinetics study of prolonged-release exenatide has been conducted in the paediatric population.

5.3 Preclinical safety data

Non-clinical data reveal no special hazards for humans based on conventional studies of safety pharmacology, repeat-dose toxicity, or genotoxicity conducted with immediate-release exenatide or prolonged-release exenatide formulations.

Thyroid tumours have been observed in rats and mice with long acting GLP-1 receptor agonists. In a 2-year rat carcinogenicity study with prolonged-release exenatide, an increased incidence of C-cell adenomas and C-cell carcinomas was observed at doses \geq 2-fold the human systemic exposure based on AUC. The clinical relevance of these findings is currently unknown.

Animal studies with exenatide did not indicate harmful effects with respect to fertility; high doses of exenatide caused skeletal effects and reduced foetal and neonatal growth.

6. PHARMACEUTICAL PARTICULARS

6.1 List of excipients

Powder

poly (D,L-lactide-co-glycolide)
sucrose

Vehicle

Medium chain triglycerides

6.2 Incompatibilities

In the absence of compatibility studies this medicinal product must not be mixed with other medicinal products.

6.3 Shelf life

3 years

6.4 Special precautions for storage

Store in a refrigerator (2°C - 8°C).

The pens may be kept for up to 4 weeks below 30°C prior to use.

Store in the original package in order to protect from light.

The pens must be stored flat.

6.5 Nature and contents of container

The suspension is packaged in a 2-ml Type I glass cartridge, sealed at one end with a (bromobutyl) rubber seal/cap combination (combiseal), and at the other end with a (bromobutyl) rubber plunger. The finished medicinal product is comprised of the suspension-filled cartridge assembled into the pen device. The pen contains an integrated needle.

Pack size of 4 single-dose pre-filled pens (BCise).

6.6 Special precautions for disposal and other handling

Pre-filled pen is for single-use only.

Patients and caregivers should be trained by their healthcare professional.

The BCise pen must be removed from the refrigerator and rested flat for at least 15 minutes prior to injection. The suspension must be mixed by shaking hard for at least 15 seconds. The suspension should be visually inspected prior to use. The suspension should only be used if it is evenly mixed, white to off-white and cloudy, with no white medicine seen along the side, bottom or top of the pen window. After the suspension is fully mixed, the preparation steps must be completed immediately and the suspension injected subcutaneously. Please see the package leaflet and “Instructions for the User” for additional information on suspension and administration.

The patient should be instructed to discard the pen safely after each injection.

Any unused medicinal product or waste material should be disposed of in accordance with local requirements.

7. MARKETING AUTHORISATION HOLDER

AstraZeneca AB
SE-151 85 Södertälje
Sweden

8. MARKETING AUTHORISATION NUMBER(S)

EU/1/11/696/005

9. DATE OF FIRST AUTHORISATION/RENEWAL OF THE AUTHORISATION

Date of first authorisation: 17 June 2011

10. DATE OF REVISION OF THE TEXT

Detailed information on this medicinal product is available on the website of the European Medicines Agency <http://www.ema.europa.eu>

ANNEX II

- A. MANUFACTURERS RESPONSIBLE FOR BATCH RELEASE**
- B. CONDITIONS OR RESTRICTIONS REGARDING SUPPLY AND USE**
- C. OTHER CONDITIONS AND REQUIREMENTS OF THE MARKETING AUTHORISATION**
- D. CONDITIONS OR RESTRICTIONS WITH REGARD TO THE SAFE AND EFFECTIVE USE OF THE MEDICINAL PRODUCT**

A. MANUFACTURERS RESPONSIBLE FOR BATCH RELEASE

Name and address of the manufacturers responsible for batch release

AstraZeneca UK Limited
Silk Road Business Park,
Macclesfield, Cheshire, SK10 2NA
United Kingdom

Swords Laboratories T/A Lawrence Laboratories
Unit 12 Distribution Centre, Shannon Industrial Estate, Shannon, Co. Clare
Ireland

The printed package leaflet of the medicinal product must state the name and address of the manufacturer responsible for the release of the concerned batch.

B. CONDITIONS OR RESTRICTIONS REGARDING SUPPLY AND USE

Medicinal product subject to medical prescription.

C. OTHER CONDITIONS AND REQUIREMENTS OF THE MARKETING AUTHORISATION

• Periodic Safety Update Reports

The requirements for submission of periodic safety update reports for this medicinal product are set out in the list of Union reference dates (EURD list) provided for under Article 107c(7) of Directive 2001/83/EC and any subsequent updates published on the European medicines webportal.

D. CONDITIONS OR RESTRICTIONS WITH REGARD TO THE SAFE AND EFFECTIVE USE OF THE MEDICINAL PRODUCT

• Risk Management Plan (RMP)

The MAH shall perform the required pharmacovigilance activities and interventions detailed in the agreed RMP presented in Module 1.8.2. of the Marketing Authorisation and any agreed subsequent updates of the RMP.

An updated RMP should be submitted:

- At the request of the European Medicines Agency;
- Whenever the risk management system is modified, especially as the result of new information being received that may lead to a significant change to the benefit/risk profile or as the result of an important (pharmacovigilance or risk minimisation) milestone being reached.

ANNEX III

LABELLING AND PACKAGE LEAFLET

A. LABELLING

PARTICULARS TO APPEAR ON THE OUTER PACKAGING

CARTON - 4 SINGLE-DOSE KITS

1. NAME OF THE MEDICINAL PRODUCT

Bydureon 2 mg powder and solvent for prolonged-release suspension for injection
exenatide

2. STATEMENT OF ACTIVE SUBSTANCE(S)

Each vial contains 2 mg exenatide

3. LIST OF EXCIPIENTS

Excipients:

Powder

poly (D,L-lactide-co-glycolide)

sucrose

Solvent:

carmellose sodium

sodium chloride

polysorbate 20

sodium dihydrogen phosphate monohydrate

disodium phosphate heptahydrate

water for injections

4. PHARMACEUTICAL FORM AND CONTENTS

Powder and solvent for prolonged-release suspension for injection.

Each carton contains 4 single-dose kits:

1 single-dose kit contains:

1 vial of 2 mg exenatide

1 pre-filled syringe of 0.65 ml solvent

1 vial connector

2 injection needles

5. METHOD AND ROUTE(S) OF ADMINISTRATION

Read the package leaflet before use.

Follow the Instructions for the User to prepare and inject your dose.

Subcutaneous use

Bydureon must be injected immediately after suspension of the powder in the solvent.

Once weekly

6. SPECIAL WARNING THAT THE MEDICINAL PRODUCT MUST BE STORED OUT OF THE SIGHT AND REACH OF CHILDREN

Keep out of the sight and reach of children.

7. OTHER SPECIAL WARNING(S), IF NECESSARY

8. EXPIRY DATE

EXP

9. SPECIAL STORAGE CONDITIONS

Store in a refrigerator.

Do not freeze.

The kit may be kept for up to 4 weeks below 30°C prior to use.

Store in the original package in order to protect from light.

10. SPECIAL PRECAUTIONS FOR DISPOSAL OF UNUSED MEDICINAL PRODUCTS OR WASTE MATERIALS DERIVED FROM SUCH MEDICINAL PRODUCTS, IF APPROPRIATE

11. NAME AND ADDRESS OF THE MARKETING AUTHORISATION HOLDER

AstraZeneca AB
SE-151 85 Södertälje
Sweden

12. MARKETING AUTHORISATION NUMBER(S)

EU/1/11/696/001

13. BATCH NUMBER

Lot

14. GENERAL CLASSIFICATION FOR SUPPLY

15. INSTRUCTIONS ON USE

16. INFORMATION IN BRAILLE

bydureon

17. UNIQUE IDENTIFIER – 2D BARCODE

2D barcode carrying the unique identifier included.

18. UNIQUE IDENTIFIER – HUMAN READABLE DATA

PC:
SN:
NN:

PARTICULARS TO APPEAR ON THE INTERMEDIATE PACKAGING

INNER CARTON, MULTIPACK OF 3 X (4 SINGLE-DOSE KITS) – WITH NO BLUE BOX

1. NAME OF THE MEDICINAL PRODUCT

Bydureon 2 mg powder and solvent for prolonged-release suspension for injection
exenatide

2. STATEMENT OF ACTIVE SUBSTANCE(S)

Each vial contains 2 mg exenatide

3. LIST OF EXCIPIENTS

Excipients:

Powder

poly (D,L-lactide-co-glycolide)

sucrose

Solvent:

carmellose sodium

sodium chloride

polysorbate 20

sodium dihydrogen phosphate monohydrate

disodium phosphate heptahydrate

water for injections

4. PHARMACEUTICAL FORM AND CONTENTS

Powder and solvent for prolonged-release suspension for injection.

Part of a multi-pack of 3 x (4 single dose kits). Do not sell separately.

Each carton contains 4 single-dose kits:

1 single-dose kit contains:

1 vial of 2 mg exenatide

1 pre-filled syringe of 0.65 ml solvent

1 vial connector

2 injection needles

5. METHOD AND ROUTE(S) OF ADMINISTRATION

Read the package leaflet before use.

Follow the Instructions for the User to prepare and inject your dose.

Subcutaneous use

Bydureon must be injected immediately after suspension of the powder in the solvent.

Once weekly

6. SPECIAL WARNING THAT THE MEDICINAL PRODUCT MUST BE STORED OUT OF THE SIGHT AND REACH OF CHILDREN

Keep out of the sight and reach of children.

7. OTHER SPECIAL WARNING(S), IF NECESSARY

8. EXPIRY DATE

EXP

9. SPECIAL STORAGE CONDITIONS

Store in a refrigerator.

Do not freeze.

The kit may be kept for up to 4 weeks below 30°C prior to use.

Store in the original package in order to protect from light.

10. SPECIAL PRECAUTIONS FOR DISPOSAL OF UNUSED MEDICINAL PRODUCTS OR WASTE MATERIALS DERIVED FROM SUCH MEDICINAL PRODUCTS, IF APPROPRIATE

11. NAME AND ADDRESS OF THE MARKETING AUTHORISATION HOLDER

AstraZeneca AB
SE-151 85 Södertälje
Sweden

12. MARKETING AUTHORISATION NUMBER(S)

EU/1/11/696/002

13. BATCH NUMBER

Lot

14. GENERAL CLASSIFICATION FOR SUPPLY

15. INSTRUCTIONS ON USE

16. INFORMATION IN BRAILLE

bydureon

17. UNIQUE IDENTIFIER – 2D BARCODE

18. UNIQUE IDENTIFIER – HUMAN READABLE DATA

PARTICULARS TO APPEAR ON THE OUTER PACKAGING

OUTER CARTON, MULTIPACK OF 3 X (4 SINGLE-DOSE KITS) - INCLUDING THE BLUE BOX

1. NAME OF THE MEDICINAL PRODUCT

Bydureon 2 mg powder and solvent for prolonged-release suspension for injection
exenatide

2. STATEMENT OF ACTIVE SUBSTANCE(S)

Each vial contains 2 mg exenatide

3. LIST OF EXCIPIENTS

Excipients:

Powder

poly (D,L-lactide-co-glycolide)

sucrose

Solvent:

carmellose sodium

sodium chloride

polysorbate 20

sodium dihydrogen phosphate monohydrate

disodium phosphate heptahydrate

water for injections

4. PHARMACEUTICAL FORM AND CONTENTS

Powder and solvent for prolonged-release suspension for injection.

Multi-pack of 3 x (4 single dose kits). Do not sell separately.

5. METHOD AND ROUTE(S) OF ADMINISTRATION

Read the package leaflet before use.

Follow the Instructions for the User to prepare and inject your dose.

Subcutaneous use

Bydureon must be injected immediately after suspension of the powder in the solvent.

Once weekly

6. SPECIAL WARNING THAT THE MEDICINAL PRODUCT MUST BE STORED OUT OF THE SIGHT AND REACH OF CHILDREN

Keep out of the sight and reach of children.

7. OTHER SPECIAL WARNING(S), IF NECESSARY

8. EXPIRY DATE

EXP

9. SPECIAL STORAGE CONDITIONS

Store in a refrigerator.

Do not freeze.

The kit may be kept for up to 4 weeks below 30°C prior to use.

Store in the original package in order to protect from light.

10. SPECIAL PRECAUTIONS FOR DISPOSAL OF UNUSED MEDICINAL PRODUCTS OR WASTE MATERIALS DERIVED FROM SUCH MEDICINAL PRODUCTS, IF APPROPRIATE

11. NAME AND ADDRESS OF THE MARKETING AUTHORISATION HOLDER

AstraZeneca AB
SE-151 85 Södertälje
Sweden

12. MARKETING AUTHORISATION NUMBER(S)

EU/1/11/696/002

13. BATCH NUMBER

Lot

14. GENERAL CLASSIFICATION FOR SUPPLY

15. INSTRUCTIONS ON USE

16. INFORMATION IN BRAILLE

bydureon

17. UNIQUE IDENTIFIER – 2D BARCODE

2D barcode carrying the unique identifier included.

18. UNIQUE IDENTIFIER – HUMAN READABLE DATA

PC:
SN:
NN:

MINIMUM PARTICULARS TO APPEAR ON SMALL IMMEDIATE PACKAGING UNITS

VIAL LABEL

1. NAME OF THE MEDICINAL PRODUCT AND ROUTE(S) OF ADMINISTRATION

Bydureon 2 mg powder for injection
exenatide
SC

2. METHOD OF ADMINISTRATION

3. EXPIRY DATE

EXP

4. BATCH NUMBER

Lot

5. CONTENTS BY WEIGHT, BY VOLUME OR BY UNIT

2 mg

6. OTHER

AstraZeneca AB

MINIMUM PARTICULARS TO APPEAR ON SMALL IMMEDIATE PACKAGING UNITS
SOLVENT LABEL

1. NAME OF THE MEDICINAL PRODUCT AND ROUTE(S) OF ADMINISTRATION

Solvent for Bydureon

2. METHOD OF ADMINISTRATION

3. EXPIRY DATE

EXP

4. BATCH NUMBER

Lot

5. CONTENTS BY WEIGHT, BY VOLUME OR BY UNIT

0.65 ml

6. OTHER

AstraZeneca AB

PARTICULARS TO APPEAR ON THE OUTER PACKAGING

CARTON (PACK OF 4 SINGLE-DOSE PRE-FILLED PENS)

1. NAME OF THE MEDICINAL PRODUCT

Bydureon 2 mg powder and solvent for prolonged-release suspension for injection in pre-filled pen exenatide

2. STATEMENT OF ACTIVE SUBSTANCE(S)

Each pre-filled pen contains 2 mg exenatide. After suspension, the delivered dose is 2 mg/0.65 ml.

3. LIST OF EXCIPIENTS

Excipients:

Powder

poly (D,L-lactide-co-glycolide)

sucrose

Solvent:

carmellose sodium

sodium chloride

polysorbate 20

sodium dihydrogen phosphate monohydrate

disodium phosphate heptahydrate

water for injections

sodium hydroxide

4. PHARMACEUTICAL FORM AND CONTENTS

Powder and solvent for prolonged-release suspension for injection.

4 single-dose pre-filled pens

1 spare injection needle

5. METHOD AND ROUTE(S) OF ADMINISTRATION

Read the package leaflet before use.

Follow the Instructions for the User to prepare and inject your dose.

Subcutaneous use

For single-use only

Bydureon must be injected immediately after mixing.

Once weekly

6. SPECIAL WARNING THAT THE MEDICINAL PRODUCT MUST BE STORED OUT OF THE SIGHT AND REACH OF CHILDREN

Keep out of the sight and reach of children.

7. OTHER SPECIAL WARNING(S), IF NECESSARY

8. EXPIRY DATE

EXP

9. SPECIAL STORAGE CONDITIONS

Store in a refrigerator.

Do not freeze.

The pre-filled pens may be kept for up to 4 weeks below 30°C prior to use.

Store in the original package in order to protect from light.

10. SPECIAL PRECAUTIONS FOR DISPOSAL OF UNUSED MEDICINAL PRODUCTS OR WASTE MATERIALS DERIVED FROM SUCH MEDICINAL PRODUCTS, IF APPROPRIATE

11. NAME AND ADDRESS OF THE MARKETING AUTHORISATION HOLDER

AstraZeneca AB
SE-151 85 Södertälje
Sweden

12. MARKETING AUTHORISATION NUMBER(S)

EU/1/11/696/003

13. BATCH NUMBER

Lot

14. GENERAL CLASSIFICATION FOR SUPPLY

15. INSTRUCTIONS ON USE

16. INFORMATION IN BRAILLE

bydureon

17. UNIQUE IDENTIFIER – 2D BARCODE

2D barcode carrying the unique identifier included.

18. UNIQUE IDENTIFIER – HUMAN READABLE DATA

PC:
SN:
NN:

PARTICULARS TO APPEAR ON THE IMMEDIATE PACKAGING

INNER CARTON MULTIPACK OF 3 X (4 SINGLE-DOSE PRE-FILLED PENS) – WITH NO BLUE BOX

1. NAME OF THE MEDICINAL PRODUCT

Bydureon 2 mg powder and solvent for prolonged-release suspension for injection in pre-filled pen exenatide

2. STATEMENT OF ACTIVE SUBSTANCE(S)

Each pre-filled pen contains 2 mg exenatide. After suspension, the delivered dose is 2 mg/0.65 ml.

3. LIST OF EXCIPIENTS

Excipients:

Powder

poly (D,L-lactide-co-glycolide)

sucrose

Solvent:

carmellose sodium

sodium chloride

polysorbate 20

sodium dihydrogen phosphate monohydrate

disodium phosphate heptahydrate

water for injections

sodium hydroxide

4. PHARMACEUTICAL FORM AND CONTENTS

Powder and solvent for prolonged-release suspension for injection.

4 single-dose pre-filled pens. Component of a multipack, can't be sold separately.

1 spare injection needle

5. METHOD AND ROUTE(S) OF ADMINISTRATION

Read the package leaflet before use.

Follow the Instructions for the User to prepare and inject your dose.

Subcutaneous use

For single-use only

Bydureon must be injected immediately after mixing.

Once weekly

6. SPECIAL WARNING THAT THE MEDICINAL PRODUCT MUST BE STORED OUT OF THE SIGHT AND REACH OF CHILDREN

Keep out of the sight and reach of children.

7. OTHER SPECIAL WARNING(S), IF NECESSARY

8. EXPIRY DATE

EXP

9. SPECIAL STORAGE CONDITIONS

Store in a refrigerator.

Do not freeze.

The pre-filled pens may be kept for up to 4 weeks below 30°C prior to use.

Store in the original package in order to protect from light.

10. SPECIAL PRECAUTIONS FOR DISPOSAL OF UNUSED MEDICINAL PRODUCTS OR WASTE MATERIALS DERIVED FROM SUCH MEDICINAL PRODUCTS, IF APPROPRIATE

11. NAME AND ADDRESS OF THE MARKETING AUTHORISATION HOLDER

AstraZeneca AB
SE-151 85 Södertälje
Sweden

12. MARKETING AUTHORISATION NUMBER(S)

EU/1/11/696/004

13. BATCH NUMBER

Lot

14. GENERAL CLASSIFICATION FOR SUPPLY

15. INSTRUCTIONS ON USE

16. INFORMATION IN BRAILLE

bydureon

17. UNIQUE IDENTIFIER – 2D BARCODE

18. UNIQUE IDENTIFIER – HUMAN READABLE DATA

PARTICULARS TO APPEAR ON THE OUTER PACKAGING

OUTER CARTON MULTIPACK OF 3 X (4 SINGLE-DOSE PRE-FILLED PENS) - INCLUDING THE BLUE BOX

1. NAME OF THE MEDICINAL PRODUCT

Bydureon 2 mg powder and solvent for prolonged-release suspension for injection in pre-filled pen exenatide

2. STATEMENT OF ACTIVE SUBSTANCE(S)

Each pre-filled pen contains 2 mg exenatide. After suspension, the delivered dose is 2 mg/0.65 ml

3. LIST OF EXCIPIENTS

Excipients:

Powder

poly (D,L-lactide-co-glycolide)

sucrose

Solvent:

carmellose sodium

sodium chloride

polysorbate 20

sodium dihydrogen phosphate monohydrate

disodium phosphate heptahydrate

water for injections

sodium hydroxide

4. PHARMACEUTICAL FORM AND CONTENTS

Powder and solvent for prolonged-release suspension for injection

Multipack: 12 (3 packs of 4) single-dose pre-filled pens

5. METHOD AND ROUTE(S) OF ADMINISTRATION

Read the package leaflet before use.

Follow the Instructions for the User to prepare and inject your dose.

Subcutaneous use

For single-use only

Bydureon must be injected immediately after mixing.

Once weekly

6. SPECIAL WARNING THAT THE MEDICINAL PRODUCT MUST BE STORED OUT OF THE SIGHT AND REACH OF CHILDREN

Keep out of the sight and reach of children.

7. OTHER SPECIAL WARNING(S), IF NECESSARY

8. EXPIRY DATE

EXP

9. SPECIAL STORAGE CONDITIONS

Store in a refrigerator.

Do not freeze.

The pre-filled pens may be kept for up to 4 weeks below 30 °C prior to use.

Store in the original package in order to protect from light.

10. SPECIAL PRECAUTIONS FOR DISPOSAL OF UNUSED MEDICINAL PRODUCTS OR WASTE MATERIALS DERIVED FROM SUCH MEDICINAL PRODUCTS, IF APPROPRIATE

11. NAME AND ADDRESS OF THE MARKETING AUTHORISATION HOLDER

AstraZeneca AB
SE-151 85 Södertälje
Sweden

12. MARKETING AUTHORISATION NUMBER(S)

EU/1/11/696/004

13. BATCH NUMBER

Lot

14. GENERAL CLASSIFICATION FOR SUPPLY

15. INSTRUCTIONS ON USE

16. INFORMATION IN BRAILLE

bydureon

17. UNIQUE IDENTIFIER – 2D BARCODE

2D barcode carrying the unique identifier included.

18. UNIQUE IDENTIFIER – HUMAN READABLE DATA

PC:
SN:
NN:

MINIMUM PARTICULARS TO APPEAR ON SMALL IMMEDIATE PACKAGING UNITS

PEN GRIP LABEL

1. NAME OF THE MEDICINAL PRODUCT AND ROUTE(S) OF ADMINISTRATION

Bydureon 2 mg powder and solvent for prolonged-release suspension for injection
exenatide
SC

2. METHOD OF ADMINISTRATION

3. EXPIRY DATE

EXP

4. BATCH NUMBER

Lot

5. CONTENTS BY WEIGHT, BY VOLUME OR BY UNIT

2 mg

6. OTHER

AstraZeneca AB

PARTICULARS TO APPEAR ON THE OUTER PACKAGING

CARTON (PACK OF 4 SINGLE-DOSE PRE-FILLED PENS)

1. NAME OF THE MEDICINAL PRODUCT

Bydureon 2 mg prolonged-release suspension for injection in pre-filled pen
exenatide

2. STATEMENT OF ACTIVE SUBSTANCE(S)

Each pre-filled pen delivers a dose of 2 mg of exenatide in 0.85 ml.

3. LIST OF EXCIPIENTS

Excipients:

Powder

poly (D,L-lactide-co-glycolide)

sucrose

Vehicle

Medium chain triglycerides (MCT)

4. PHARMACEUTICAL FORM AND CONTENTS

Prolonged-release suspension for injection

4 single-dose pre-filled pens (BCise)

BCise

5. METHOD AND ROUTE(S) OF ADMINISTRATION

Follow the instructions for the user to prepare and inject your dose.

Single-use only

Once weekly

Shake well before use.

Bydureon must be injected immediately after mixing and preparation.

Read the package leaflet before use.

Subcutaneous use

6. SPECIAL WARNING THAT THE MEDICINAL PRODUCT MUST BE STORED OUT OF THE SIGHT AND REACH OF CHILDREN

Keep out of the sight and reach of children.

7. OTHER SPECIAL WARNING(S), IF NECESSARY

8. EXPIRY DATE

EXP

9. SPECIAL STORAGE CONDITIONS

Store in a refrigerator.

The pre-filled pen may be kept for up to 4 weeks below 30°C prior to use.

Store in the original package in order to protect from light.

The pre-filled pen must be stored flat.

10. SPECIAL PRECAUTIONS FOR DISPOSAL OF UNUSED MEDICINAL PRODUCTS OR WASTE MATERIALS DERIVED FROM SUCH MEDICINAL PRODUCTS, IF APPROPRIATE

11. NAME AND ADDRESS OF THE MARKETING AUTHORISATION HOLDER

AstraZeneca AB
SE-151 85 Södertälje
Sweden

12. MARKETING AUTHORISATION NUMBER(S)

EU/1/11/696/005

13. BATCH NUMBER

Lot

14. GENERAL CLASSIFICATION FOR SUPPLY

15. INSTRUCTIONS ON USE

16. INFORMATION IN BRAILLE

bydureon bcise

17. UNIQUE IDENTIFIER – 2D BARCODE

2D barcode carrying the unique identifier included.

18. UNIQUE IDENTIFIER – HUMAN READABLE DATA

PC:
SN:
NN:

**MINIMUM PARTICULARS TO APPEAR ON SMALL IMMEDIATE PACKAGING UNITS
PRE-FILLED PEN LABEL**

1. NAME OF THE MEDICINAL PRODUCT AND ROUTE(S) OF ADMINISTRATION

Bydureon 2 mg prolonged-release suspension for injection
exenatide
SC
BCise

2. METHOD OF ADMINISTRATION

3. EXPIRY DATE

EXP

4. BATCH NUMBER

Lot

5. CONTENTS BY WEIGHT, BY VOLUME OR BY UNIT

2 mg

6. OTHER

AstraZeneca AB

B. PACKAGE LEAFLET

Package Leaflet: Information for the user

Bydureon 2 mg powder and solvent for prolonged-release suspension for injection exenatide

Read all of this leaflet carefully before you start using this medicine because it contains important information for you.

- Keep this leaflet. You may need to read it again.
- If you have any further questions, ask your doctor, pharmacist, or diabetes nurse.
- This medicine has been prescribed for you only. Do not pass it on to others. It may harm them, even if their signs of illness are the same as yours.
- If you get any side effects, talk to your doctor, pharmacist, or diabetes nurse. This includes any possible side effects not listed in this leaflet. See section 4.

What is in this leaflet

1. What Bydureon is and what it is used for
2. What you need to know before you use Bydureon
3. How to use Bydureon
4. Possible side effects
5. How to store Bydureon
6. Contents of the pack and other information

1. What Bydureon is and what it is used for

Bydureon contains the active substance exenatide. It is an injectable medicine used to improve blood sugar control in adults with type 2 diabetes mellitus.

This medicine is used in combination with the following diabetes medicines: metformin, sulphonylureas, thiazolidinediones, SGLT2 inhibitors and/or a long-acting insulin. Your doctor is now prescribing this medicine as an additional medicine to help control your blood sugar. Continue to follow your food and exercise plan.

You have diabetes because your body does not make enough insulin to control the level of sugar in your blood or your body is not able to use the insulin properly. This medicine helps your body to increase the production of insulin when your blood sugar is high.

2. What you need to know before you use Bydureon

Do not use Bydureon:

- If you are allergic to exenatide or any of the other ingredients of this medicine (listed in section 6).

Warnings and precautions

Talk to your doctor, pharmacist, or diabetes nurse before using Bydureon about the following:

- If you use this medicine in combination with a sulphonylurea, as low blood sugar (hypoglycaemia) can occur. Test your blood glucose levels regularly. Ask your doctor, pharmacist, or diabetes nurse if you are not sure if any of your other medicines contain a sulphonylurea.
- If you have type 1 diabetes or diabetic ketoacidosis, as this medicine should not be used.
- How to inject this medicine. It should be injected into the skin and not into a vein or into the muscle.
- If you have severe problems with your stomach emptying (including gastroparesis) or food digestion, as the use of this medicine is not recommended. The active substance in this medicine slows stomach emptying so food passes more slowly through your stomach.

- If you have ever had inflammation of the pancreas (pancreatitis) (see section 4).
- If you lose weight too quickly (more than 1.5 kg per week) talk to your doctor about it since this may cause problems such as gallstones.
- If you have severe kidney disease or you are on dialysis, as the use of this medicine is not recommended. There is little experience with this medicine in patients with kidney problems.

Children and adolescents

Do not give this medicine to children and adolescents less than 18 years, as there is no experience with this medicine in this age group.

Other medicines and Bydureon

Tell your doctor or pharmacist if you are taking, have recently taken, or might take any other medicines, particularly:

- other medicines that are used to treat type 2 diabetes, such as medicines that work like Bydureon (for example: liraglutide or other exenatide containing products), as taking these medicines with Bydureon is not recommended.
- medicines used to thin the blood (anticoagulants), e.g. Warfarin, as you will require additional monitoring of changes in INR (measurement of blood thinning) during initiation of therapy with this medicine.
- a medicine that contains a sulphonylurea, as low blood sugar (hypoglycaemia) can occur when combined with Bydureon.

Pregnancy and breast-feeding

It is not known if this medicine may harm your unborn child, therefore you should not use it during pregnancy and for at least 3 months before a planned pregnancy.

It is not known if exenatide passes into your milk. You should not use this medicine while breast-feeding.

If you are pregnant or breast-feeding, think you may be pregnant, or are planning to have a baby, ask your doctor or pharmacist for advice before taking this medicine.

You should use contraception if you could potentially become pregnant during treatment with this medicine.

Driving and using machines

If you use this medicine in combination with a sulphonylurea, low blood sugar (hypoglycaemia) can occur. Hypoglycaemia may reduce your ability to concentrate. Please keep this possible problem in mind in all situations where you might put yourself and others at risk (e.g. driving a car or using machines).

Important information about some of the ingredients of Bydureon

This medicine contains less than 1 mmol sodium (23 mg) per dose, i.e. essentially “sodium-free”.

3. How to use Bydureon

Always use this medicine exactly as your doctor, pharmacist, or diabetes nurse has told you. Check with your doctor, pharmacist, or diabetes nurse if you are not sure.

You should inject this medicine once a week, at any time of day, with or without meals.

You should inject this medicine into the skin (subcutaneous injection) of your stomach area (abdomen), upper leg (thigh), or the back of your upper arm. Do not inject into a vein or muscle.

Each week you can use the same area of your body. Be sure to choose a different injection site in that area.

Never mix insulin and Bydureon together in the same injection. If you need to give yourself both at the same time, use two separate injections. You may give both injections in the same body area (for example, your stomach area), but you should not give the injections next to each other. Test your blood glucose levels regularly, it is particularly important to do this if you are also using a sulphonylurea.

Follow the “Instructions for the User” provided in the carton to inject Bydureon

Your doctor or diabetes nurse should teach you how to inject this medicine before you use it for the first time.

Check that the liquid in the syringe is clear and free of particles before you begin. After mixing, use the suspension only if the mixture is white to off white and cloudy. If you see clumps of dry powder on the sides or bottom of the vial, the medicine is NOT mixed well. Shake vigorously again until well mixed.

You should inject this medicine immediately after mixing the powder and the solvent.

Use a new injection needle for each injection and dispose of it safely after each use as instructed by your doctor or diabetes nurse.

If you use more Bydureon than you should

If you use more of this medicine than you should, please consult with your doctor first as you may need medical treatment. Using too much of this medicine can cause nausea, vomiting, dizziness, or symptoms of low blood sugar (see section 4).

If you forget to use Bydureon

You might like to choose a day that you always plan to make your Bydureon injection.

If you miss a dose and there are 3 days or more until your next dose is due, then take the missed dose as soon as it is possible to do so. For your next injection you can return to your chosen injection day. If you miss a dose and there are only 1 or 2 days until your next dose is due, skip the missed dose and take the next one as usual, on the day it is due. You can also change your chosen injection day, as long as your last dose was given 3 or more days before.

Do not take two doses of Bydureon within 3 days of each other.

If you are not sure you have taken the full dose of Bydureon

If you are not sure if you have taken all of your dose, do not inject another dose of this medicine, just take it next week as planned.

If you stop using Bydureon

If you feel you should stop using this medicine, please consult your doctor first. If you stop using this medicine this can affect your blood sugar levels.

If you have any further questions on the use of this medicine, ask your doctor, pharmacist, or diabetes nurse.

4. Possible side effects

Like all medicines, this medicine can cause side effects, although not everybody gets them.

Severe allergic reactions (anaphylaxis) have been reported rarely (may affect up to 1 in 1,000 people).

You should see your doctor immediately if you experience symptoms such as

- Swelling of the face, tongue or throat (angioedema)
- Hypersensitivity (rashes, itching and rapid swelling of the tissues of the neck, face, mouth or throat)
- Difficulty with swallowing
- Hives and difficulty with breathing

Cases of inflammation of the pancreas (pancreatitis) have been reported uncommonly (may affect up to 1 in 100 people) in patients receiving this medicine. Pancreatitis can be a serious, potentially life-threatening medical condition.

- Tell your doctor if you have had pancreatitis, gallstones, alcoholism or very high triglycerides. These medical conditions can increase the risk of getting pancreatitis, or getting it again, whether or not you are taking this medicine.
- **STOP** taking this medicine and contact your doctor immediately if you experience **severe and persistent** stomach pain, with or without vomiting, because you could have an inflamed pancreas (pancreatitis).

Very common side effects (may affect more than 1 in 10 people)

- nausea (nausea is most common when first starting this medicine, but decreases over time in most patients)
- diarrhoea
- hypoglycaemia (low blood sugar) when taken with a medicine that contains a **sulphonylurea**.

When this medicine is used with a medicine that contains a **sulphonylurea**, episodes of low blood sugar (hypoglycaemia, generally mild to moderate) can occur. The dose of your sulphonylurea medicine may need to be reduced while you use this medicine. The signs and symptoms of low blood sugar may include headache, drowsiness, weakness, dizziness, confusion, irritability, hunger, fast heartbeat, sweating, and feeling jittery. Your doctor should tell you how to treat low blood sugar.

Common side effects (may affect up to 1 in 10 people)

- hypoglycaemia (low blood sugar) when taken with an insulin
- dizziness
- headache
- vomiting
- loss of energy and strength
- tiredness (fatigue)
- constipation
- pain in the stomach area
- bloating
- indigestion
- flatulence (passing gas)
- heartburn
- reduced appetite

This medicine may reduce your appetite, the amount of food you eat, and your weight.

If you lose weight too quickly (more than 1.5 kg per week) talk to your doctor about it since this may cause problems such as gallstones.

- injection site reactions

If you have an injection site reaction (redness, rash, or itching) you may like to ask your doctor for something to help relieve any signs or symptoms. You may see or feel a small bump under the skin after your injection; it should go away after 4 to 8 weeks. You should not need to stop your treatment.

Uncommon side effects

- decrease in kidney function
- dehydration, sometimes with a decrease in kidney function

- intestinal obstruction (blockage in intestine)
- burping
- unusual taste in the mouth
- increased sweating
- hair loss
- sleepiness

Rare side effects

- feeling jittery

Not known (frequency cannot be estimated from the available data)

In addition some **other side effects** have been reported .

- changes in INR (measurement of blood thinning) have been reported when used together with warfarin
- skin reactions at the injection site following injection of exenatide. These include: cavity containing pus (abscess) and swollen, or red area of skin that feels hot and tender (cellulitis).

Reporting of side effects

If you get any side effects, talk to your doctor, pharmacist or diabetes nurse. This includes any possible side effects not listed in this leaflet. You can also report side effects directly via **the national reporting system** listed in [Appendix V](#). By reporting side effects, you can help provide more information on the safety of this medicine.

5. How to store Bydureon

Keep this medicine out of the sight and reach of children.

Do not use this medicine after the expiry date, which is stated on the label and the carton after EXP. The expiry date refers to the last day of that month.

Store in a refrigerator (2°C to 8°C). Do not freeze.
The kit may be kept for up to 4 weeks below 30°C prior to use.
Store in the original package in order to protect from light.
Throw away any Bydureon kit that has been frozen.

Do not throw away any medicines via wastewater or household waste. Ask your pharmacist how to throw away medicines you no longer use. These measures will help protect the environment.

6. Contents of the pack and other information

What Bydureon contains

- The active substance is exenatide. Each vial contains 2 mg of exenatide.
- The other ingredients are:
- In the powder: poly (D,L-lactide-co-glycolide) and sucrose.
- In the solvent: carmellose sodium, sodium chloride, polysorbate 20, sodium dihydrogen phosphate monohydrate, disodium phosphate heptahydrate and water for injection.

What Bydureon looks like and contents of the pack

Powder and solvent for prolonged-release suspension for injection.

The powder is white to off-white and the solvent is a clear, colourless to pale yellow to pale brown solution.

Each single-dose kit consists of one vial containing 2 mg exenatide powder, one pre-filled syringe containing 0.65 ml solvent, one vial connector, and two injection needles. One needle is a spare.

This medicine is available in pack sizes of 4 single-dose kits and 3 packs of 4 single-dose kits. Not all pack sizes may be marketed.

Marketing Authorisation Holder

AstraZeneca AB
SE-151 85 Södertälje
Sweden

Manufacturer

AstraZeneca UK Limited
Silk Road Business Park,
Macclesfield, Cheshire, SK10 2NA
United Kingdom

Swords Laboratories T/A Lawrence Laboratories
Unit 12 Distribution Centre, Shannon Industrial Estate, Shannon, Co. Clare
Ireland

For any information about this medicine, please contact the local representative of the Marketing Authorisation Holder:

België/Belgique/Belgien

AstraZeneca S.A./N.V.
Tel: +32 2 370 48 11

Lietuva

UAB AstraZeneca Lietuva
Tel: +370 5 2660550

България

АстраЗенека България ЕООД
Тел.: +359 (2) 44 55 000

Luxembourg/Luxemburg

AstraZeneca S.A./N.V.
Tél/Tel: +32 2 370 48 11

Česká republika

AstraZeneca Czech Republic s.r.o.
Tel: +420 222 807 111

Magyarország

AstraZeneca Kft.
Tel.: +36 1 883 6500

Danmark

AstraZeneca A/S
Tlf: +45 43 66 64 62

Malta

Associated Drug Co. Ltd
Tel: +356 2277 8000

Deutschland

AstraZeneca GmbH
Tel: +49 41 03 7080

Nederland

AstraZeneca BV
Tel: +31 79 363 2222

Eesti

AstraZeneca
Tel: +372 6549 600

Norge

AstraZeneca AS
Tlf: +47 21 00 64 00

Ελλάδα

AstraZeneca A.E.

Österreich

AstraZeneca Österreich GmbH

Τηλ: +30 210 6871500

España

AstraZeneca Farmacéutica Spain, S.A.
Tel: +34 91 301 91 00

France

AstraZeneca
Tél: +33 1 41 29 40 00

Hrvatska

AstraZeneca d.o.o.
Tel: +385 1 4628 000

Ireland

AstraZeneca Pharmaceuticals (Ireland) DAC
Tel: +353 1609 7100

Ísland

Vistor hf.
Sími: +354 535 7000

Italia

AstraZeneca S.p.A.
Tel: +39 02 9801 1

Κύπρος

Αλέκτωρ Φαρμακευτική Λτδ
Τηλ: +357 22490305

Latvija

SIA AstraZeneca Latvija
Tel: +371 67377100

Tel: +43 1 711 31 0

Polska

AstraZeneca Pharma Poland Sp. z o.o.
Tel.: +48 22 245 73 00

Portugal

AstraZeneca Produtos Farmacêuticos, Lda.
Tel: +351 21 434 61 00

România

AstraZeneca Pharma SRL
Tel: +40 21 317 60 41

Slovenija

AstraZeneca UK Limited
Tel: +386 1 51 35 600

Slovenská republika

AstraZeneca AB, o.z.
Tel: +421 2 5737 7777

Suomi/Finland

AstraZeneca Oy
Puh/Tel: +358 10 23 010

Sverige

AstraZeneca AB
Tel: +46 8 553 26 000

United Kingdom

AstraZeneca UK Ltd
Tel: +44 1582 836 836

This leaflet was last revised in

Other sources of information

Detailed information on this medicine is available on the website of the European Medicines Agency

<http://www.ema.europa.eu/>

Package Leaflet: Information for the user

Bydureon 2 mg powder and solvent for prolonged-release suspension for injection in pre-filled pen exenatide

Read all of this leaflet carefully before you start using this medicine because it contains important information for you.

- Keep this leaflet. You may need to read it again.
- If you have any further questions, ask your doctor, pharmacist, or diabetes nurse.
- This medicine has been prescribed for you only. Do not pass it on to others. It may harm them, even if their signs of illness are the same as yours.
- If you get any side effects, talk to your doctor, pharmacist, or diabetes nurse. This includes any possible side effects not listed in this leaflet. See section 4.

What is in this leaflet

1. What Bydureon is and what it is used for
2. What you need to know before you use Bydureon
3. How to use Bydureon
4. Possible side effects
5. How to store Bydureon
6. Contents of the pack and other information

1. What Bydureon is and what it is used for

Bydureon contains the active substance exenatide. It is an injectable medicine used to improve blood sugar control in adults with type 2 diabetes mellitus.

This medicine is used in combination with the following diabetes medicines: metformin, sulphonylureas, thiazolidinediones, SGLT2 inhibitors and/or a long-acting insulin. Your doctor is now prescribing this medicine as an additional medicine to help control your blood sugar. Continue to follow your food and exercise plan

You have diabetes because your body does not make enough insulin to control the level of sugar in your blood or your body is not able to use the insulin properly. This medicine helps your body to increase the production of insulin when your blood sugar is high.

2. What you need to know before you use Bydureon

Do not use Bydureon:

- If you are allergic to exenatide or any of the other ingredients of this medicine (listed in section 6).

Warnings and precautions

Talk to your doctor, pharmacist, or diabetes nurse before using Bydureon about the following:

- If you use this medicine in combination with a sulphonylurea, as low blood sugar (hypoglycaemia) can occur. Test your blood glucose levels regularly. Ask your doctor, pharmacist, or diabetes nurse if you are not sure if any of your other medicines contain a sulphonylurea.
- If you have type 1 diabetes or diabetic ketoacidosis, as this medicine should not be used.
- How to inject this medicine. It should be injected into the skin and not into a vein or into the muscle.

- If you have severe problems with your stomach emptying (including gastroparesis) or food digestion, as the use of this medicine is not recommended. The active substance in this medicine slows stomach emptying so food passes more slowly through your stomach.
- If you have ever had inflammation of the pancreas (pancreatitis) (see section 4).
- If you lose weight too quickly (more than 1.5 kg per week) talk to your doctor about it since this may cause problems such as gallstones.
- If you have severe kidney disease or you are on dialysis, as the use of this medicine is not recommended. There is little experience with this medicine in patients with kidney problems.

Children and adolescents

Do not give this medicine to children and adolescents less than 18 years, as there is no experience with this medicine in this age group.

Other medicines and Bydureon

Tell your doctor or pharmacist if you are taking, have recently taken, or might take any other medicines, particularly:

- other medicines that are used to treat type 2 diabetes such as medicines that work like Bydureon (for example: liraglutide or other exenatide containing products), as taking these medicines with Bydureon is not recommended.
- medicines used to thin the blood (anticoagulants), e.g. Warfarin, as you will require additional monitoring of changes in INR (measurement of blood thinning) during initiation of therapy with this medicine.
- a medicine that contains a sulphonylurea, as low blood sugar (hypoglycaemia) can occur when combined with Bydureon.

Pregnancy and breast-feeding

It is not known if this medicine may harm your unborn child, therefore you should not use it during pregnancy and for at least 3 months before a planned pregnancy.

It is not known if exenatide passes into your milk. You should not use this medicine while breast-feeding.

If you are pregnant or breast-feeding, think you may be pregnant, or are planning to have a baby, ask your doctor or pharmacist for advice before taking this medicine.

You should use contraception if you could potentially become pregnant during treatment with this medicine.

Driving and using machines

If you use this medicine in combination with a sulphonylurea, low blood sugar (hypoglycaemia) can occur. Hypoglycaemia may reduce your ability to concentrate. Please keep this possible problem in mind in all situations where you might put yourself and others at risk (e.g. driving a car or using machines).

Important information about some of the ingredients of Bydureon

This medicine contains less than 1 mmol sodium (23 mg) per dose, i.e. essentially “sodium-free”.

3. How to use Bydureon

Always use this medicine exactly as your doctor, pharmacist, or diabetes nurse has told you. Check with your doctor, pharmacist, or diabetes nurse if you are not sure.

You should inject this medicine once a week, at any time of day, with or without meals.

You should inject this medicine into the skin (subcutaneous injection) of your stomach area (abdomen), upper leg (thigh), or the back of your upper arm. Do not inject into a vein or muscle.

Each week you can use the same area of your body. Be sure to choose a different injection site in that area.

Never mix insulin and Bydureon together in the same injection. If you need to give yourself both at the same time, use two separate injections. You may give both injections in the same body area (for example, your stomach area), but you should not give the injections next to each other.

Test your blood glucose levels regularly, it is particularly important to do this if you are also using a sulphonylurea.

Follow the “Instructions for the User” provided in the carton to inject Bydureon

Your doctor or diabetes nurse should teach you how to inject this medicine before you use it for the first time.

Check that the liquid in the pen is clear and free of particles before you begin. After mixing the liquid with the powder, use the suspension only if the mixture is white to off white and cloudy. If you see clumps of dry powder on the sides of the pen, the medicine is NOT mixed well. Tap vigorously again until well mixed.

You should inject this medicine immediately after mixing the powder and the solvent.

Use a new pen for each injection. You should dispose of the pen safely, with the needle still attached, after use, as instructed by your doctor or diabetes nurse.

If you use more Bydureon than you should

If you use more of this medicine than you should, please consult with your doctor first as you may need medical treatment. Using too much of this medicine can cause nausea, vomiting, dizziness, or symptoms of low blood sugar (see section 4).

If you forget to use Bydureon

You might like to choose a day that you always plan to make your Bydureon injection.

If you miss a dose and there are 3 days or more until your next dose is due, then take the missed dose as soon as it is possible to do so. For your next injection you can return to your chosen injection day. If you miss a dose and there are only 1 or 2 days until your next dose is due, skip the missed dose and take the next one as usual, on the day it is due. You can also change your chosen injection day, as long as your last dose was given 3 or more days before.

Do not take two doses of Bydureon within 3 days of each other.

If you are not sure you have taken the full dose of Bydureon

If you are not sure if you have taken all of your dose, do not inject another dose of this medicine, just take it next week as planned.

If you stop using Bydureon

If you feel you should stop using this medicine, please consult your doctor first. If you stop using this medicine this can affect your blood sugar levels.

If you have any further questions on the use of this medicine, ask your doctor, pharmacist, or diabetes nurse.

4. Possible side effects

Like all medicines, this medicine can cause side effects, although not everybody gets them.

Severe allergic reactions (anaphylaxis) have been reported rarely (may affect up to 1 in 1,000 people).

You should see your doctor immediately if you experience symptoms such as

- Swelling of the face, tongue or throat (angioedema)
- Hypersensitivity (rashes, itching and rapid swelling of the tissues of the neck, face, mouth or throat)
- Difficulty with swallowing
- Hives and difficulty with breathing

Cases of inflammation of the pancreas (pancreatitis) have been reported uncommonly (may affect up to 1 in 100 people) in patients receiving this medicine. Pancreatitis can be a serious, potentially life-threatening medical condition.

- Tell your doctor if you have had pancreatitis, gallstones, alcoholism or very high triglycerides. These medical conditions can increase the risk of getting pancreatitis, or getting it again, whether or not you are taking this medicine.
- STOP taking this medicine and contact your doctor immediately if you experience **severe and persistent** stomach pain, with or without vomiting, because you could have an inflamed pancreas (pancreatitis).

Very common side effects (may affect more than 1 in 10 people)

- nausea (nausea is most common when first starting this medicine, but decreases over time in most patients)
- diarrhoea
- hypoglycaemia (low blood sugar) when taken with a medicine that contains a **sulphonylurea**

When this medicine is used with a medicine that contains a **sulphonylurea**, episodes of low blood sugar (hypoglycaemia, generally mild to moderate) can occur. The dose of your sulphonylurea medicine may need to be reduced while you use this medicine. The signs and symptoms of low blood sugar may include headache, drowsiness, weakness, dizziness, confusion, irritability, hunger, fast heartbeat, sweating, and feeling jittery. Your doctor should tell you how to treat low blood sugar.

Common side effects (may affect up to 1 in 10 people)

- hypoglycaemia (low blood sugar) when taken with an insulin
- dizziness
- headache
- vomiting
- loss of energy and strength
- tiredness (fatigue)
- constipation
- pain in the stomach area
- bloating
- indigestion
- flatulence (passing gas)
- heartburn
- reduced appetite

This medicine may reduce your appetite, the amount of food you eat, and your weight.

If you lose weight too quickly (more than 1.5 kg per week) talk to your doctor about it since this may cause problems such as gallstones.

- injection site reactions

If you have an injection site reaction (redness, rash, or itching) you may like to ask your doctor for something to help relieve any signs or symptoms. You may see or feel a small bump under the skin after your injection; it should go away after 4 to 8 weeks. You should not need to stop your treatment.

Uncommon side effects

- decrease in kidney function
- dehydration, sometimes with a decrease in kidney function
- intestinal obstruction (blockage in intestine)
- burping
- unusual taste in the mouth
- increased sweating
- hair loss
- sleepiness

Rare side effects

- feeling jittery

Not known (frequency cannot be estimated from the available data)

In addition some **other side effects** have been reported .

- changes in INR (measurement of blood thinning) have been reported when used together with warfarin
- skin reactions at the injection site following injection of exenatide. These include: cavity containing pus (abscess) and swollen, or red area of skin that feels hot and tender (cellulitis).

Reporting of side effects

If you get any side effects, talk to your doctor, pharmacist or diabetes nurse. This includes any possible side effects not listed in this leaflet. You can also report side effects directly via the [national reporting system](#) listed in [Appendix V](#). By reporting side effects, you can help provide more information on the safety of this medicine.

5. How to store Bydureon

Keep this medicine out of the sight and reach of children.

Do not use this medicine after the expiry date, which is stated on the label and the carton after EXP. The expiry date refers to the last day of that month.

Store in a refrigerator (2°C to 8°C). Do not freeze.
The pen may be kept for up to 4 weeks below 30°C prior to use.
Store in the original package in order to protect from light.
Throw away any Bydureon pen that has been frozen.

Do not throw away any medicines via wastewater or household waste. Ask your pharmacist how to throw away medicines you no longer use. These measures will help protect the environment.

6. Contents of the pack and other information

What Bydureon contains

- The active substance is exenatide. Each pre-filled pen contains 2 mg of exenatide. After suspension, the delivered dose is 2 mg/0.65 ml.
- The other ingredients are:
- In the powder: poly (D,L-lactide-co-glycolide) and sucrose.
- In the solvent: carmellose sodium, sodium chloride, polysorbate 20, sodium dihydrogen phosphate monohydrate, disodium phosphate heptahydrate, water for injection and sodium hydroxide (for pH adjustment).

What Bydureon looks like and contents of the pack

This medicine is provided as a powder and solvent (liquid) for suspension for injection in a pre-filled pen. The powder (2 mg) in one chamber, is white to off-white and the solvent (0.65 ml) in the other chamber, is a clear, colourless to pale yellow to pale brown solution. Each single-dose pre-filled pen is provided with one custom needle. Each carton also contains one spare needle.

This medicine is available in pack of 4 single-dose pre-filled pens, and a multipack containing 12 (3 packs of 4) single-dose pre-filled pens. Not all pack sizes may be marketed.

Marketing Authorisation Holder

AstraZeneca AB
SE-151 85 Södertälje
Sweden

Manufacturer

AstraZeneca UK Limited
Silk Road Business Park,
Macclesfield, Cheshire, SK10 2NA
United Kingdom

Swords Laboratories T/A Lawrence Laboratories
Unit 12 Distribution Centre, Shannon Industrial Estate, Shannon, Co. Clare
Ireland

For any information about this medicine, please contact the local representative of the Marketing Authorisation Holder:

België/Belgique/Belgien

AstraZeneca S.A./N.V.
Tel: +32 2 370 48 11

Lietuva

UAB AstraZeneca Lietuva
Tel: +370 5 2660550

България

АстраЗенека България ЕООД
Тел.: +359 (2) 44 55 000

Luxembourg/Luxemburg

AstraZeneca S.A./N.V.
Tél/Tel: +32 2 370 48 11

Česká republika

AstraZeneca Czech Republic s.r.o.
Tel: +420 222 807 111

Magyarország

AstraZeneca Kft.
Tel.: +36 1 883 6500

Danmark

AstraZeneca A/S
Tlf: +45 43 66 64 62

Malta

Associated Drug Co. Ltd
Tel: +356 2277 8000

Deutschland

AstraZeneca GmbH
Tel: +49 41 03 7080

Nederland

AstraZeneca BV
Tel: +31 79 363 2222

Eesti

AstraZeneca
Tel: +372 6549 600

Norge

AstraZeneca AS
Tlf: +47 21 00 64 00

Ελλάδα

AstraZeneca A.E.
Τηλ: +30 210 6871500

Österreich

AstraZeneca Österreich GmbH
Tel: +43 1 711 31 0

España

AstraZeneca Farmacéutica Spain, S.A.
Tel: +34 91 301 91 00

France

AstraZeneca
Tél: +33 1 41 29 40 00

Hrvatska

AstraZeneca d.o.o.
Tel: +385 1 4628 000

Ireland

AstraZeneca Pharmaceuticals (Ireland) DAC
Tel: +353 1609 7100

Ísland

Vistor hf.
Sími: +354 535 7000

Italia

AstraZeneca S.p.A.
Tel: +39 02 9801 1

Κύπρος

Αλέκτωρ Φαρμακευτική Λτδ
Τηλ: +357 22490305

Latvija

SIA AstraZeneca Latvija
Tel: +371 67377100

Polska

AstraZeneca Pharma Poland Sp. z o.o.
Tel.: +48 22 245 73 00

Portugal

AstraZeneca Produtos Farmacêuticos, Lda.
Tel: +351 21 434 61 00

România

AstraZeneca Pharma SRL
Tel: +40 21 317 60 41

Slovenija

AstraZeneca UK Limited
Tel: +386 1 51 35 600

Slovenská republika

AstraZeneca AB, o.z.
Tel: +421 2 5737 7777

Suomi/Finland

AstraZeneca Oy
Puh/Tel: +358 10 23 010

Sverige

AstraZeneca AB
Tel: +46 8 553 26 000

United Kingdom

AstraZeneca UK Ltd
Tel: +44 1582 836 836

This leaflet was last revised in

Other sources of information

Detailed information on this medicine is available on the website of the European Medicines Agency
<http://www.ema.europa.eu/>

Package Leaflet: Information for the user

Bydureon 2 mg prolonged-release suspension for injection in pre-filled pen exenatide

Read all of this leaflet carefully before you start using this medicine because it contains important information for you.

- Keep this leaflet. You may need to read it again.
- If you have any further questions, ask your doctor, pharmacist, or diabetes nurse.
- This medicine has been prescribed for you only. Do not pass it on to others. It may harm them, even if their signs of illness are the same as yours.
- If you get any side effects, talk to your doctor, pharmacist, or diabetes nurse. This includes any possible side effects not listed in this leaflet. See section 4.

What is in this leaflet

1. What Bydureon is and what it is used for
2. What you need to know before you use Bydureon
3. How to use Bydureon
4. Possible side effects
5. How to store Bydureon
6. Contents of the pack and other information

1. What Bydureon is and what it is used for

Bydureon contains the active substance exenatide. It is an injectable medicine used to improve blood sugar control in adults with type 2 diabetes mellitus.

This medicine is used in combination with the following diabetes medicines: metformin, sulphonylureas, thiazolidinediones, SGLT2 inhibitors and/or a long-acting insulin. Your doctor is now prescribing this medicine as an additional medicine to help control your blood sugar. Continue to follow your food and exercise plan.

You have diabetes because your body does not make enough insulin to control the level of sugar in your blood or your body is not able to use the insulin properly. This medicine helps your body to increase the production of insulin when your blood sugar is high.

2. What you need to know before you use Bydureon

Do not use Bydureon:

- If you are allergic to exenatide or any of the other ingredients of this medicine (listed in section 6).

Warnings and precautions

Talk to your doctor, pharmacist, or diabetes nurse before using Bydureon about the following:

- If you use this medicine in combination with a sulphonylurea, as low blood sugar (hypoglycaemia) can occur. Test your blood glucose levels regularly. Ask your doctor, pharmacist, or diabetes nurse if you are not sure if any of your other medicines contain a sulphonylurea.
- If you have type 1 diabetes or diabetic ketoacidosis, as this medicine should not be used.
- How to inject this medicine. It should be injected into the skin and not into a vein or into the muscle.
- If you have severe problems with your stomach emptying (including gastroparesis) or food digestion, as the use of this medicine is not recommended. The active substance in this medicine slows stomach emptying so food passes more slowly through your stomach.

- If you have ever had inflammation of the pancreas (pancreatitis) (see section 4).
- If you lose weight too quickly (more than 1.5 kg per week) talk to your doctor about it since this may cause problems such as gallstones.
- If you have severe kidney disease or you are on dialysis, as the use of this medicine is not recommended. There is little experience with this medicine in patients with kidney problems.

Children and adolescents

Do not give this medicine to children and adolescents less than 18 years, as there is no experience with this medicine in this age group.

Other medicines and Bydureon

Tell your doctor or pharmacist if you are taking, have recently taken, or might take any other medicines, particularly:

- other medicines that are used to treat type 2 diabetes, such as medicines that work like Bydureon (for example: liraglutide or other exenatide containing products, as taking these medicines with Bydureon is not recommended).
- medicines used to thin the blood (anticoagulants), e.g. Warfarin, as you will require additional monitoring of changes in INR (measurement of blood thinning) during initiation of therapy with this medicine.
- a medicine that contains a sulphonylurea, as low blood sugar (hypoglycaemia) can occur when combined with Bydureon.

Pregnancy and breast-feeding

It is not known if this medicine may harm your unborn child, therefore you should not use it during pregnancy and for at least 3 months before a planned pregnancy.

It is not known if exenatide passes into your milk. You should not use this medicine while breast-feeding.

If you are pregnant or breast-feeding, think you may be pregnant, or are planning to have a baby, ask your doctor or pharmacist for advice before taking this medicine.

You should use contraception if you could potentially become pregnant during treatment with this medicine.

Driving and using machines

If you use this medicine in combination with a sulphonylurea, low blood sugar (hypoglycaemia) can occur. Hypoglycaemia may reduce your ability to concentrate. Please keep this possible problem in mind in all situations where you might put yourself and others at risk (e.g. driving a car or using machines).

3. How to use Bydureon

BCise is the name of the pre-filled pen device used to inject your Bydureon medicine.

Always use this medicine exactly as your doctor, pharmacist, or diabetes nurse has told you. Check with your doctor, pharmacist, or diabetes nurse if you are not sure.

You should inject this medicine once a week, at any time of day, with or without meals.

You should inject this medicine into the skin (subcutaneous injection) of your stomach area (abdomen), upper leg (thigh), or the back of your upper arm. Do not inject into a vein or muscle.

Each week you can use the same area of your body. Be sure to choose a different injection site in that area.

Test your blood glucose levels regularly, it is particularly important to do this if you are also using a sulphonylurea.

Follow the “Instructions for the User” provided in the carton to inject Bydureon BCise

Your doctor or diabetes nurse should teach you how to inject this medicine before you use it for the first time.

Remove one pen from the refrigerator and rest it flat for at least 15 minutes. Mix the suspension by shaking hard for at least 15 seconds. Use the suspension only if it is evenly mixed, white to off-white and cloudy. If you see white medicine on the sides, bottom or top of the pen window, the medicine is NOT mixed well. Shake hard again until well mixed.

You should inject this medicine immediately after mixing the suspension.

Use a new pen for each injection. You should dispose of the pen safely after each use, as instructed by your doctor or diabetes nurse.

If you use more Bydureon than you should

If you use more of this medicine than you should, please consult your doctor first as you may need medical treatment. Using too much of this medicine can cause nausea, vomiting, dizziness, or symptoms of low blood sugar (see section 4).

If you forget to use Bydureon

You might like to choose a day that you always plan to make your Bydureon injection.

If you miss a dose and there are 3 days or more until your next dose is due, then take the missed dose as soon as it is possible to do so. For your next injection you can return to your chosen injection day. If you miss a dose and there are only 1 or 2 days until your next dose is due, skip the missed dose and take the next one as usual, on the day it is due. You can also change your chosen injection day, as long as your last dose was given 3 or more days before.

Do not take two doses of Bydureon within 3 days of each other.

If you are not sure you have taken the full dose of Bydureon

If you are not sure if you have taken all of your dose, do not inject another dose of this medicine, just take it next week as planned.

If you stop using Bydureon

If you feel you should stop using this medicine, please consult your doctor first. If you stop using this medicine this can affect your blood sugar levels.

If you have any further questions on the use of this medicine, ask your doctor, pharmacist, or diabetes nurse.

4. Possible side effects

Like all medicines, this medicine can cause side effects, although not everybody gets them.

Severe allergic reactions (anaphylaxis) have been reported rarely (may affect up to 1 in 1,000 people).

You should see your doctor immediately if you experience symptoms such as

- Swelling of the face, tongue or throat (angioedema)
- Hypersensitivity (rashes, itching and rapid swelling of the tissues of the neck, face, mouth or throat)

- Difficulty with swallowing
- Hives and difficulty with breathing

Cases of inflammation of the pancreas (pancreatitis) have been reported uncommonly (may affect up to 1 in 100 people) in patients receiving this medicine. Pancreatitis can be a serious, potentially life-threatening medical condition.

- Tell your doctor if you have had pancreatitis, gallstones, alcoholism or very high triglycerides. These medical conditions can increase the risk of getting pancreatitis, or getting it again, whether or not you are taking this medicine.
- STOP taking this medicine and contact your doctor immediately if you experience **severe and persistent** stomach pain, with or without vomiting, because you could have an inflamed pancreas (pancreatitis).

Very common side effects (may affect more than 1 in 10 people)

- hypoglycaemia (low blood sugar) when taken with a medicine that contains a **sulphonylurea**

When this medicine is used with a medicine that contains a **sulphonylurea**, episodes of low blood sugar (hypoglycaemia, generally mild to moderate) can occur. The dose of your sulphonylurea medicine may need to be reduced while you use this medicine. The signs and symptoms of low blood sugar may include headache, drowsiness, weakness, dizziness, confusion, irritability, hunger, fast heartbeat, sweating, and feeling jittery. Your doctor should tell you how to treat low blood sugar.

Common side effects (may affect up to 1 in 10 people)

- hypoglycaemia (low blood sugar) when taken with an insulin
- headache
- dizziness
- nausea (nausea is most common when starting this medicine, but decreases over time in most patients)
- diarrhoea
- vomiting
- constipation
- indigestion
- heartburn
- bloating
- pain in the stomach area
- injection site itchiness or redness
- tiredness (fatigue)

Uncommon side effects

- hypoglycaemia (low blood sugar) when this medicine is used with a medicine that does not contain a **sulphonylurea**
- reduced appetite

This medicine may reduce your appetite, the amount of food you eat, and your weight.

If you lose weight too quickly (more than 1.5 kg per week) talk to your doctor about it since this may cause problems such as gallstones.

- dehydration
- unusual taste in the mouth
- sleepiness
- flatulence (passing gas)
- burping
- intestinal obstruction (blockage in intestine)
- hives
- increased sweating

- rash, itching
- hair loss
- decrease in kidney function
- injection site reactions

If you have an injection site reaction (redness, rash, or itching) you may like to ask your doctor for something to help relieve any signs or symptoms. You may see or feel a small bump under the skin after your injection; it should go away after 4 to 8 weeks. You should not need to stop your treatment.

- loss of energy and strength

Rare side effects

- feeling jittery

Not known (frequency cannot be estimated from the available data)

In addition some **other side effects** have been reported

- skin reactions at the injection site following injection of exenatide. These include: cavity containing pus (abscess) and swollen, or red area of skin that feels hot and tender (cellulitis).
- changes in INR (measurement of blood thinning) have been reported when used together with warfarin

Reporting of side effects

If you get any side effects, talk to your doctor, pharmacist or diabetes nurse. This includes any possible side effects not listed in this leaflet. You can also report side effects directly via the national reporting system listed in [Appendix V](#). By reporting side effects, you can help provide more information on the safety of this medicine.

5. How to store Bydureon

Keep this medicine out of the sight and reach of children.

Do not use this medicine after the expiry date, which is stated on the label and the carton after EXP. The expiry date refers to the last day of that month.

Bydureon BCise pen should be stored as follows:

- Store in a refrigerator (2°C to 8°C).
- The pen may be kept for up to 4 weeks below 30°C prior to use.
- Store in the original package in order to protect from light.
- The pen must be stored flat.

Do not throw away any medicines via wastewater or household waste. Ask your pharmacist how to throw away medicines you no longer use. These measures will help protect the environment.

6. Contents of the pack and other information

What Bydureon BCise pen contains

- The active substance is exenatide. Each pre-filled pen contains 2 mg of exenatide.
- The other ingredients are: poly (D,L-lactide-co-glycolide), sucrose and medium chain triglyceride.

What Bydureon looks like and contents of the pack

Prolonged-release suspension for injection in pre-filled pen (BCise).

White to off-white opaque suspension.

Each pre-filled pen delivers 2 mg of exenatide in a volume of 0.85 ml.

It is available in a pack size of 4 single-dose pre-filled pens.

Marketing Authorisation Holder

AstraZeneca AB
SE-151 85 Södertälje
Sweden

Manufacturer

AstraZeneca UK Limited
Silk Road Business Park,
Macclesfield, Cheshire, SK10 2NA
United Kingdom

For any information about this medicine, please contact the local representative of the Marketing Authorisation Holder:

België/Belgique/Belgien

AstraZeneca S.A./N.V.
Tel: +32 2 370 48 11

Lietuva

UAB AstraZeneca Lietuva
Tel: +370 5 2660550

България

АстраЗенека България ЕООД
Тел.: +359 (2) 44 55 000

Luxembourg/Luxemburg

AstraZeneca S.A./N.V.
Tél/Tel: +32 2 370 48 11

Česká republika

AstraZeneca Czech Republic s.r.o.
Tel: +420 222 807 111

Magyarország

AstraZeneca Kft.
Tel.: +36 1 883 6500

Danmark

AstraZeneca A/S
Tlf: +45 43 66 64 62

Malta

Associated Drug Co. Ltd
Tel: +356 2277 8000

Deutschland

AstraZeneca GmbH
Tel: +49 41 03 7080

Nederland

AstraZeneca BV
Tel: +31 79 363 2222

Eesti

AstraZeneca
Tel: +372 6549 600

Norge

AstraZeneca AS
Tlf: +47 21 00 64 00

Ελλάδα

AstraZeneca A.E.
Τηλ: +30 210 6871500

Österreich

AstraZeneca Österreich GmbH
Tel: +43 1 711 31 0

España

AstraZeneca Farmacéutica Spain, S.A.
Tel: +34 91 301 91 00

Polska

AstraZeneca Pharma Poland Sp. z o.o.
Tel.: +48 22 245 73 00

France

Portugal

AstraZeneca
Tél: +33 1 41 29 40 00

Hrvatska

AstraZeneca d.o.o.
Tel: +385 1 4628 000

Ireland

AstraZeneca Pharmaceuticals (Ireland) DAC
Tel: +353 1609 7100

Ísland

Vistor hf.
Sími: +354 535 7000

Italia

AstraZeneca S.p.A.
Tel: +39 02 9801 1

Κύπρος

Αλέκτωρ Φαρμακευτική Λτδ
Τηλ: +357 22490305

Latvija

SIA AstraZeneca Latvija
Tel: +371 67377100

AstraZeneca Produtos Farmacêuticos, Lda.
Tel: +351 21 434 61 00

România

AstraZeneca Pharma SRL
Tel: +40 21 317 60 41

Slovenija

AstraZeneca UK Limited
Tel: +386 1 51 35 600

Slovenská republika

AstraZeneca AB, o.z.
Tel: +421 2 5737 7777

Suomi/Finland

AstraZeneca Oy
Puh/Tel: +358 10 23 010

Sverige

AstraZeneca AB
Tel: +46 8 553 26 000

United Kingdom

AstraZeneca UK Ltd
Tel: +44 1582 836 836

This leaflet was last revised in

Other sources of information

Detailed information on this medicine is available on the website of the European Medicines Agency
<http://www.ema.europa.eu/>

INSTRUCTIONS FOR THE USER

Your step by step guide

Bydureon 2 mg powder and solvent for prolonged-release suspension for injection

If you have questions about taking Bydureon

- Refer to the **Common questions and answers**

Helpful hints

- Take your time.
- Follow these instructions step by step.
- You will need enough time to complete all the steps without stopping.
- You will probably need less time as you get used to giving yourself injections.

IMPORTANT:

Read and follow each step in these instructions carefully *every time* you take Bydureon. Do not skip steps. Also read the *Package Leaflet* in your carton.

Your guide to the parts

Single-dose kit

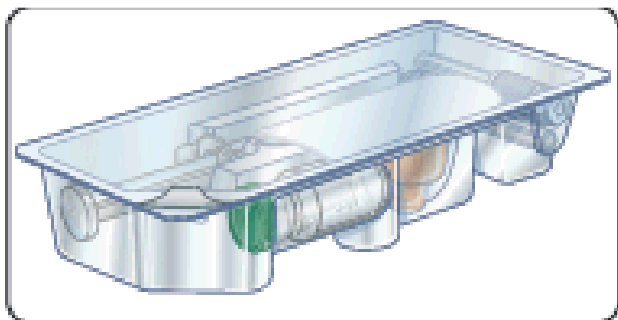

Lift here for a closer look at the parts

Keep this flap open so you can refer to it as you go through the steps

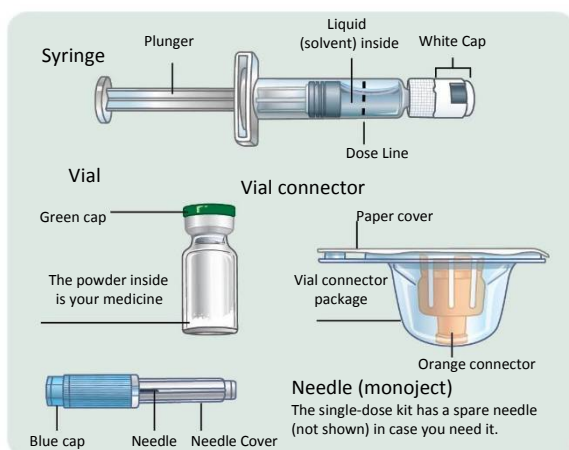

Your guide to the parts

Single-dose kit

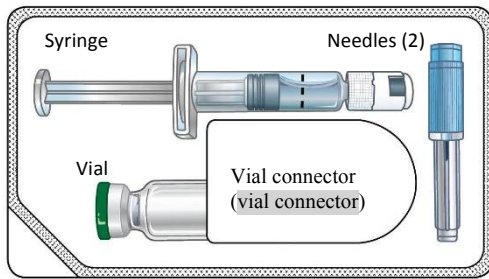

What's inside

To take the correct dose, read each section so that you do every step in order.

This guide is divided into sections:

- 1 Getting started
- 2 Connecting the parts
- 3 Mixing the medicine and filling the syringe
- 4 Injecting the medicine

Common questions and answers.

1. Getting Started

1a Take a single-dose kit from the refrigerator.

Prepare to safely dispose of used needles and syringes. Have what you need ready in order to safely dispose of used needles and syringes.

1b Wash your hands.

1c

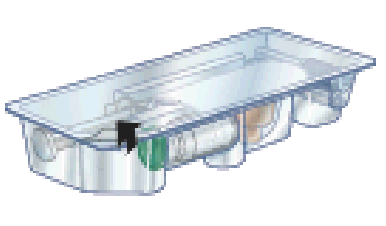

Peel back the cover to open.

Remove the syringe. The liquid in the syringe should be clear and free of particles. It is okay if there are air bubbles.

Place the needle, vial connector package, vial, and syringe on a clean, flat surface.

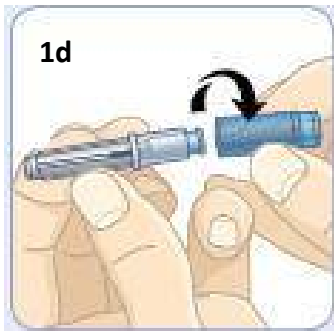

Pick up the needle, and twist off the blue cap.

Put the covered needle down. The needle is now prepared. You will need it later.

There is a spare needle in case you need it.



Pick up the vial.

Tap the vial several times against a hard surface to loosen the powder.



Use your thumb to remove the green cap.

Put the vial down.

2. Connecting the parts



Pick up the vial connector package and peel off the paper cover. Do not touch the orange connector inside.

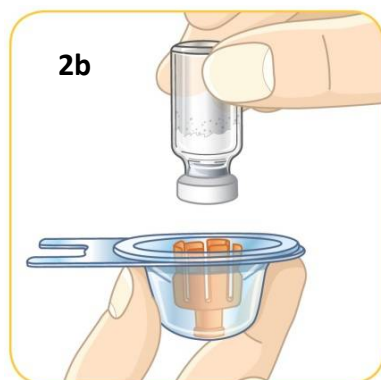

Hold the vial connector package. In your other hand, hold the vial.

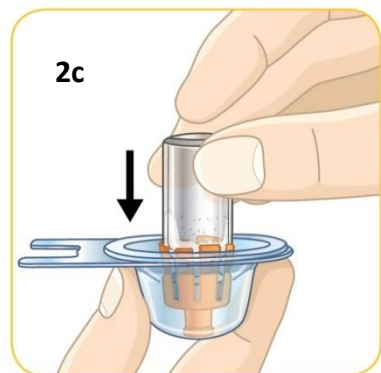

Press the top of the vial firmly into the orange connector.

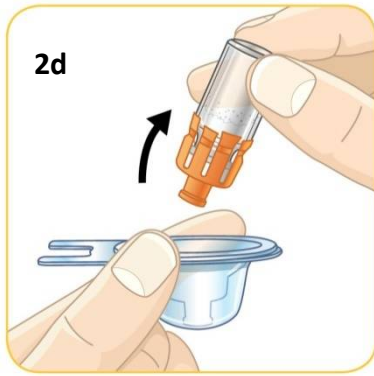

Lift the vial with the orange connector now attached out of its package.



This is what the vial should now look like.

Put it down for later.



Pick up the syringe.

With your other hand, firmly hold the 2 grey squares on the white cap.

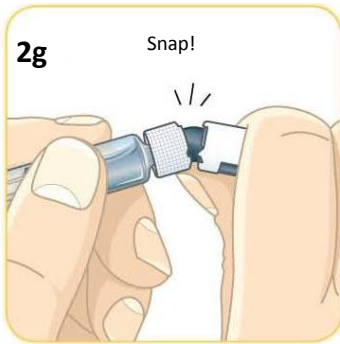

Break off the cap

Be careful not to push in the plunger.

Just like you might break a stick, you are breaking off the cap.



This is what the broken-off cap looks like.

You will not need the cap and can throw it away.



This is what the syringe should now look like.



Now, pick up the vial with the orange connector attached.

Twist the orange connector onto the syringe until snug. While twisting, be sure to hold the orange connector. Do not over tighten. Be careful not to push in the plunger.

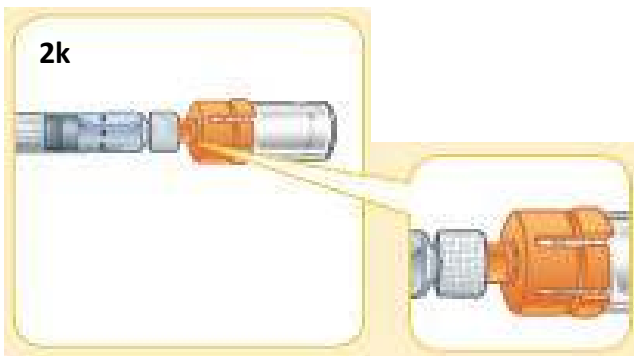

This is how the parts should now look when they are connected.

3. Mixing the medicine and filling the syringe

IMPORTANT:

During these next steps, you will be mixing the medicine and filling the syringe. Once you mix the medicine, you must inject it immediately. **You must not save the mixed medicine to inject at a later time.**

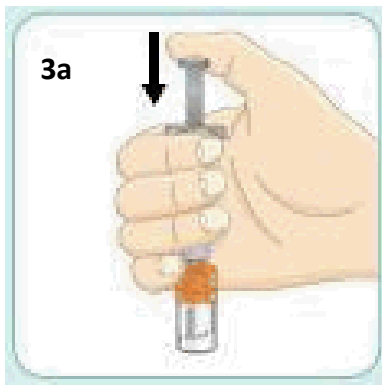

With your thumb, push down the plunger until it stops and hold your thumb in place.

The plunger may feel like it is springing back a little.



Keep pushing down on the plunger with your thumb and shake vigorously. Keep shaking until the liquid and powder are mixed well.

Do not worry that the vial might come off. The orange connector will keep it attached to the syringe.

Shake vigorously like you would shake a bottle of oil-and-vinegar salad dressing.



When the medicine is mixed well, it should look cloudy.



If you see clumps of dry powder on the sides or bottom of the vial, the medicine is **NOT** mixed well.

Shake vigorously again until well mixed.

Keep pushing on the plunger with your thumb while shaking.



Now, hold the vial so the syringe is pointing up. Keep pushing on the plunger with your thumb until it stops, and hold it in place.



Gently tap the vial with the other hand. Keep pushing on the plunger with your thumb to keep the plunger in place.

The tapping helps the medicine drip down along the sides of the vial. It is okay if there are air bubbles.

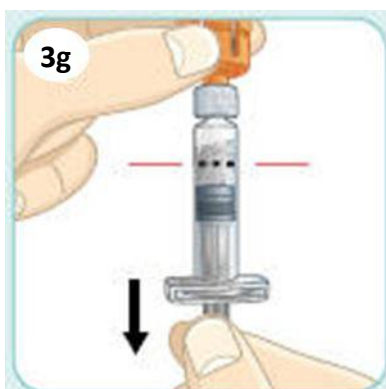

Pull the plunger down beyond the black dashed Dose Line.

This draws the medicine from the vial into the syringe. You may see air bubbles. This is normal.

A little bit of liquid may cling to the sides of the vial. This is also normal.



With one hand, hold the plunger in place so it does not move.

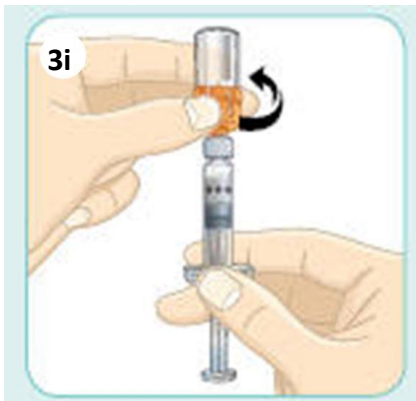

With the other hand, twist the orange connector to remove.

After removing the connector be careful not to push in the plunger.



This is what the syringe should now look like.

4. Injecting the medicine

IMPORTANT:

Read the next steps carefully and look closely at the pictures.
This helps you get the correct dose of medicine.

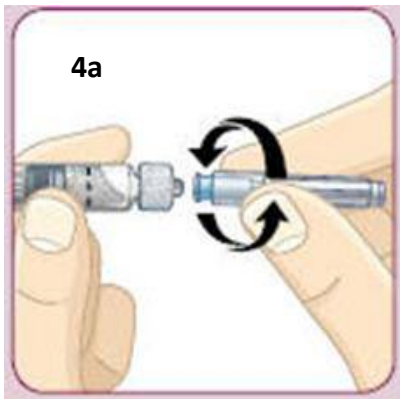

Twist the needle onto the syringe until snug. Do not remove the needle cover yet. Be careful not to push in the plunger.

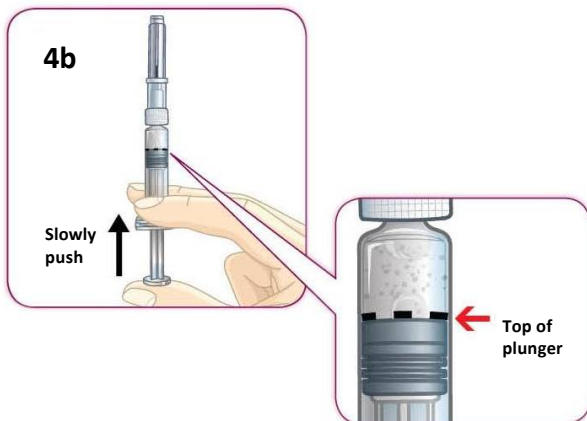

Slowly push in the plunger so the top of the plunger lines up with the black dashed Dose Line. Then, take your thumb off the plunger.

It is important to stop pushing at this point, or you will waste your medicine and you will not get the correct dose.



The top of the plunger must stay lined up with the black dashed Dose Line as you go through the next steps. This will help you get the correct dose of medicine.

IMPORTANT:

**It is normal to see a few air bubbles in the mixture.
The air bubbles will not harm you or affect your dose.**

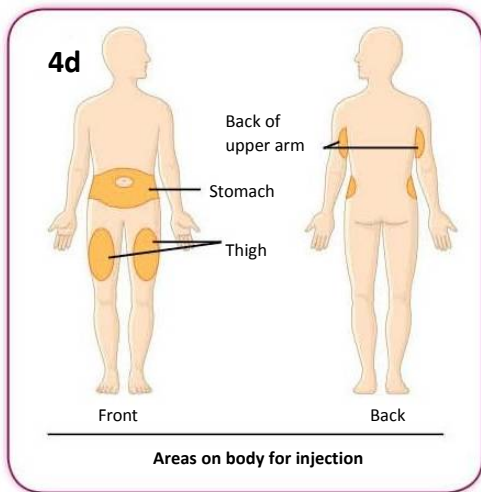

You can inject each dose of the medicine in your stomach area (abdomen), your thigh, or the back of your upper arm.

Each week you can use the same area of your body. But be sure to choose a different injection site in that area.

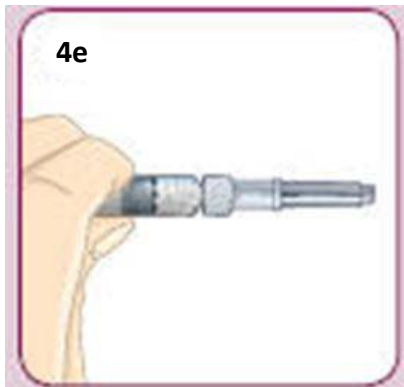

Hold the syringe near the black dashed Dose Line.

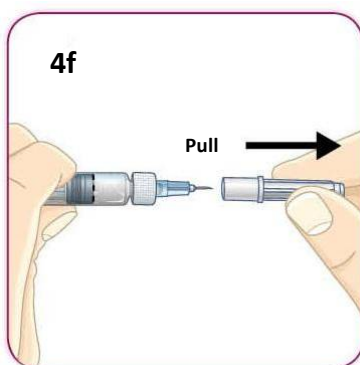

Pull the needle cover straight off.
Do not twist.

Be careful not to push in the plunger.

When you remove the cover, you may see 1 or 2 drops of liquid. This is normal.



Be sure to use the injection technique recommended by your doctor or diabetes nurse.
Remember: You must take your injection of Bydureon immediately after mixing it.

Insert the needle into your skin (subcutaneously). To inject your full dose, push down on the plunger with your thumb until it stops.

Withdraw the needle.

Refer to the package leaflet (section 3) on what to do if you are not sure if you have received a complete dose.

4h. Dispose of the syringe with the needle still attached as instructed by your doctor or diabetes nurse. DO NOT try to recap or reuse the needle.

You do not have to save any parts. Each single-dose kit has everything you need for your weekly dose of Bydureon.

Medicines should not be disposed of via waste water or household waste. Ask your pharmacist how to dispose of medicines no longer required. These measures will help to protect the environment.

When it is time for your next weekly dose, start again at step 1.

Common questions and answers

If your question is about:

How soon to inject after mixing

Mixing the medicine

Air bubbles in syringe

Attaching the needle

Removing the needle cover

Plunger not lining up with black dashed Dose Line

Being unable to push the plunger down when injecting

See question number:

1

2

3

4

5

6

7

Common questions and answers

1. After I mix the medicine, how long can I wait before taking the injection?

You must take your injection of Bydureon immediately after mixing it. If you do not inject Bydureon immediately, the medicine will start to form small clumps in the syringe. These clumps could clog the needle when you take the injection (see question 7).

2. How do I know that the medicine is mixed well?

When the medicine is mixed well, it should look cloudy. There should not be any dry powder on the sides or bottom of the vial. If you do see any dry powder, shake vigorously while continuing to push down on the plunger with your thumb. (This question relates to the steps shown in sections 3a to 3d).

3. I'm ready to take the injection. What should I do if I see air bubbles in the syringe?

It is normal for air bubbles to be in the syringe. The air bubbles will not harm you or affect your dose. Bydureon is injected into your skin (subcutaneously). Air bubbles are not a problem with this type of injection.

4. What should I do if I have trouble attaching the needle?

First, be sure you have removed the blue cap. Then, twist the needle onto the syringe until snug. To prevent losing medicine, do not push in the plunger while attaching the needle. For more information on injection techniques talk with your health care professional.
(This question relates to step 4a.)

5. What should I do if I have trouble removing the needle cover?

With one hand, hold the syringe near the black dashed Dose Line. With your other hand, hold the needle cover. Pull the needle cover straight off. Do not twist it. (This question relates to step 4f.)

6. I am at step 4c. What should I do if the top of the plunger has been pushed past the black dashed Dose Line?

The black dashed Dose Line shows the correct dose. If the top of the plunger has been pushed past the line, you should continue from step 4d and take the injection. Before your next injection in 1 week, carefully review the instructions for steps 3a to 4h.

7. When I inject, what should I do if I cannot push the plunger all the way down?

This means the needle has become clogged. Remove the needle and replace it with the spare needle from your kit. Then choose a different injection site and finish taking the injection.

To review how to:

- Remove the blue cap of the needle, see step 1d
- Attach the needle, see step 4a
- Remove the needle cover and give the injection, see steps 4e to 4g

If you still cannot push the plunger all the way down, withdraw the needle. Refer to the package leaflet (section 3) on what to do if you are not sure if you have received a complete dose.

To prevent a clogged needle, always mix the medicine very well, and inject immediately after mixing.

Bydureon only needs to be taken once a week.

Make a note that you have taken your Bydureon today and mark your calendar for when you are due for your next injection.

Where to learn more about Bydureon

- **Talk with your doctor, pharmacist or diabetes nurse**
- **Read the Package Leaflet carefully**

INSTRUCTIONS FOR THE USER
Read these instructions carefully before use

Bydureon 2 mg powder and solvent for prolonged-release suspension for injection in pre-filled pen

How to use Bydureon pre-filled pen

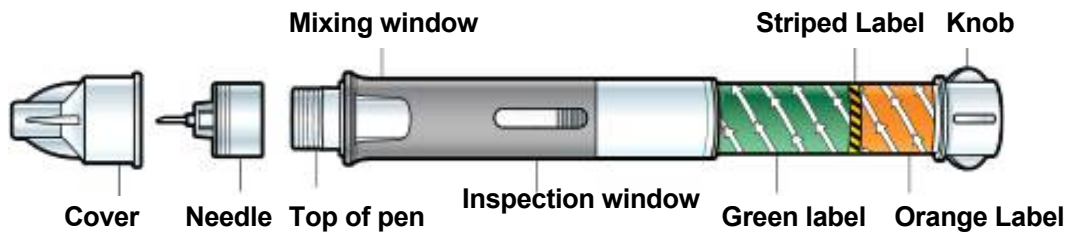

Prior to use of the pen, it is recommended that you should be trained by a doctor or diabetes nurse on its proper use.

Unless a trained person can help to inject this medicine it is not recommended for people who are blind or cannot see well.

Step 1: Prepare your pen

Let your pen warm up. Remove one pen from the refrigerator and let it stand at room temperature for at least 15 minutes. **DO NOT** use a pen past its expiration date.



Wash your hands while the pen is warming up.

Open the tray by pulling on the corner tab. Then remove the pen and needle. **DO NOT** use your pen or needle if any parts are broken or missing.

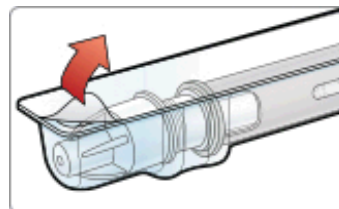

Check the liquid inside the inspection window. It should be clear and free of particles. It's normal if you see air bubbles in the liquid.

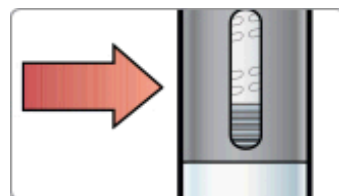

Peel off the paper tab from the needle cover.



Attach the needle to the pen by pushing and screwing it onto the top of the pen until it is tight. **DO NOT** remove the needle cover yet.

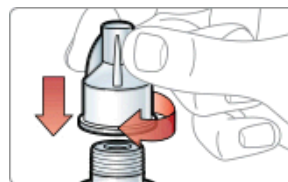

Step 2: Mix your dose

Combine the medicine. While holding the pen upright with the needle cover uppermost, **slowly** turn the knob anticlockwise. **STOP** when you hear the click and the green label disappears.

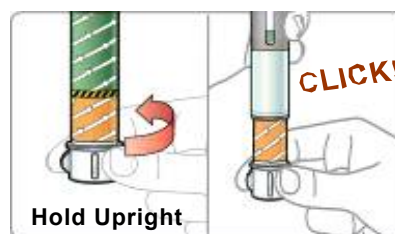

Firmly tap the pen to mix. Hold the pen by the end with the orange label and **tap the pen firmly against the palm of your hand.** **WITHOUT** twisting the knob, **ROTATE** the pen every few taps. Tap the prefilled pen firmly until a uniformly cloudy suspension with no clumps is obtained. You may need to tap 80 times or more.



Check the suspension. Hold the pen up to the light and look through both sides of the mixing window. The solution should have **NO CLUMPS** and be uniformly cloudy.

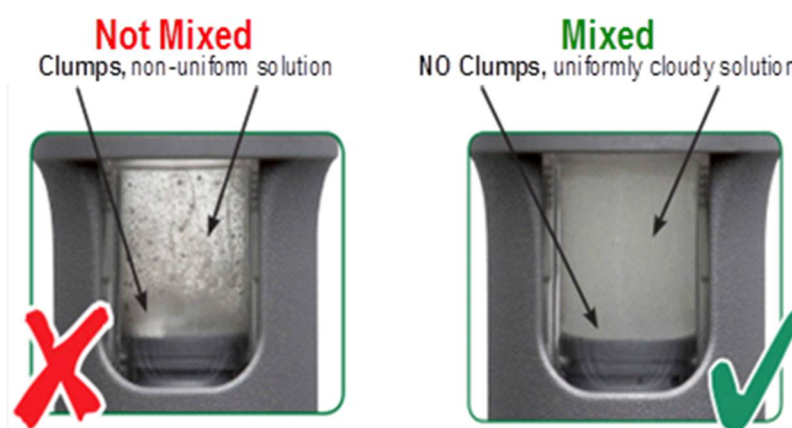

To get your full dose the medicine must be mixed well.

If it's not mixed well, tap longer and more firmly.



DO NOT proceed unless your medicine is mixed well

To get your full dose the medicine must be mixed well. If it's not mixed well, tap longer and more firmly. It's normal if you see air bubbles in the liquid, and they will cause no harm.

Compare both sides of the mixing window to the photos below by holding the pen against the page. Pay attention to the **bottom surface**. If you **don't see clumps** you are ready to inject.

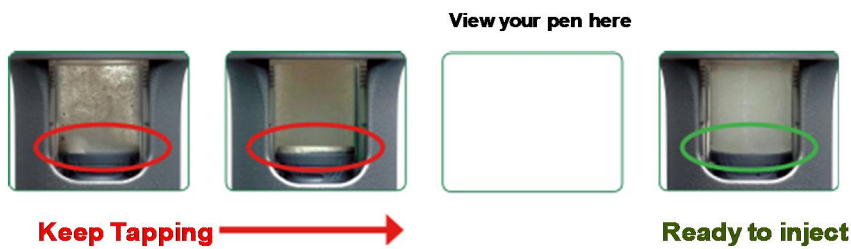

Step 3: Inject your dose

IMPORTANT Once the medicine is mixed well, you must inject the dose immediately. You cannot save it for later use.

Choose your injection site in either your stomach, thigh, or back of the arm. Each week you can use the same area of your body but choose a different injection site in that area.

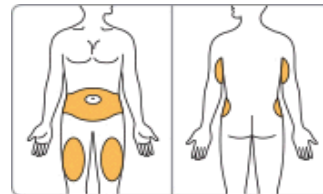

Gently clean the area with soap and water or an alcohol swab.

Twist knob to release injection button.

While holding the **pen upright** with the needle cover uppermost, twist the knob anticlockwise until the orange label disappears and the injection button is released. **DO NOT** push the injection button yet.

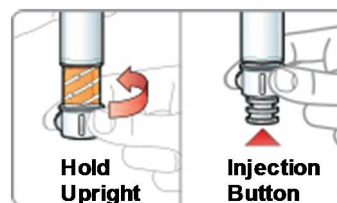

Remove the needle cover by pulling straight off. **DO NOT** twist. You may see a few drops of liquid on the needle or in the cover.

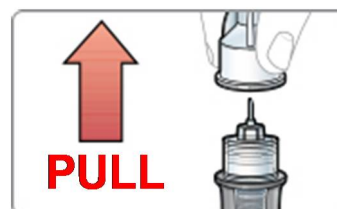

Inject the medicine. Insert the needle into your skin (subcutaneously). Press the injection button with your thumb until you hear a click. **Hold for 10 seconds** to make sure you get the full dose.

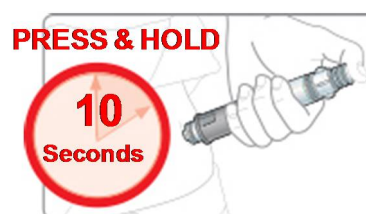

Properly dispose of your pen, with the needle attached, in a puncture-resistant container. **DO NOT** try to recap or reuse the needle.

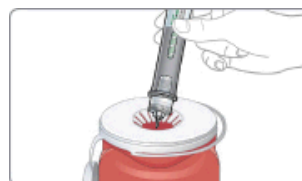

Common Questions and Answers

1. How do I know that the medicine is mixed well?

The medicine is mixed well when the liquid looks cloudy from both sides of the window. You should not see any clumps in the liquid. It may help to hold the pen up to the light to see in the window. If you see clumps of any size keep tapping the pen firmly against the palm of your hand until mixed.

2. I am having trouble mixing my dose. What should I do?

Remember, before preparing your dose, leave the pen out of the refrigerator for at least 15 minutes. This will let the pen warm up to room temperature. It will be easier to mix the medicine if the pen is at room temperature.

Be sure you are holding the pen at the end with the knob and the orange label. This will help you grip the pen better and tap it more firmly against your palm.

It may also help to tap the mixing window on both sides against your palm. If you see any clumps, keep tapping.

3. After I mix the medicine, how long can I wait before taking the injection?

You must inject your dose right after mixing it. If you do not inject your dose right away, small clumps of medicine may form in the pen and you may not get your full dose.

4. I'm ready to inject my dose. What should I do if I see air bubbles in the pen?

It is normal for air bubbles to be in the pen. The medicine is injected into your skin (subcutaneously). Air bubbles will not harm you or affect your dose with this type of injection.

5. What should I do if I cannot push the injection button all the way in when trying to inject my dose?

Check that you have fully screwed on the pen needle. Also be sure you twisted the knob until it stopped, the orange label disappeared, and the injection button appears.

If you still cannot push the button in, this may mean that the needle is clogged. Remove the needle from your skin and replace it with the spare needle from the carton. Review how to attach the needle. Then choose a different injection site and finish taking the injection.

If you still cannot push the button all the way in, remove the needle from your skin. Use a puncture-resistant container to throw away the pen with the needle still attached.

6. How do I know if I injected my full dose?

To be sure you get your full dose, press the injection button with your thumb until you hear a click. After the click, continue to hold the needle in your skin for 10 seconds. This will allow enough time for all the medicine to go from the pen to under your skin.

7. How do I dispose of my Bydureon pen?

You will need a puncture-resistant container that is large enough to hold the entire pen with a used needle attached. Be sure the container has a lid. You may use a biohazard container, another hard plastic container, or a metal container. A container is not included in the carton.

Ask your pharmacist how to safely throw away the container with used pens and needles. Do not throw the container in your household waste.

INSTRUCTIONS FOR THE USER

Read these instructions carefully before use

Read also the Package Leaflet in your carton

Bydureon 2 mg prolonged-release suspension for injection in pre-filled pen

For subcutaneous use only

Single-dose pre-filled pen once weekly

BCise is the name of the pre-filled pen device used to inject your Bydureon medicine.



Before You Begin

The Bydureon BCise pen:

- Is a single use, fixed dose pen that automatically injects your medicine.
- Comes in the locked position before you use it. Do not unlock the pen until you are ready to inject it.
- Needle is hidden. You do not see it before, during, or after using the pen.
- **Do not** use the pen if any parts look to be broken or damaged.
- Store flat in the refrigerator between 2°C to 8°C.
- Bydureon BCise pen should **not** be used by people who are blind or cannot see well, unless another person who is trained to use this device can help.
- Keep the pen, and all medicines, out of the reach of children.

Before Use

Your doctor or diabetes nurse should teach you how to inject this medicine before you use it for the first time

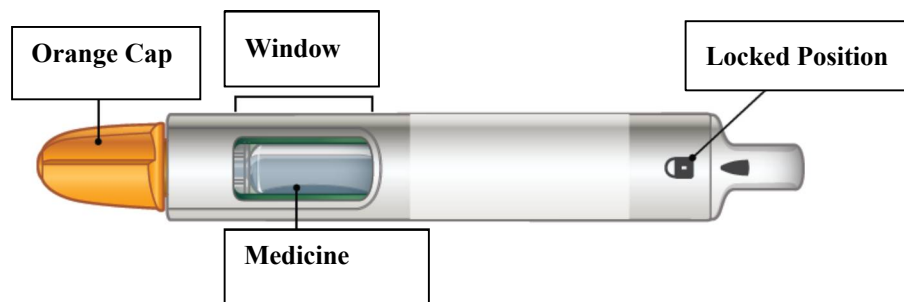

Figure A

Supplies needed to give your injection:

- Bydureon BCise pen
- Alcohol swab
- A clean, flat surface
- Puncture-resistant container (see “disposal” instructions at the end of these instructions)

STEP 1: Prepare for injection

A. Let your pen come to room temperature.

Remove 1 pen from the refrigerator and rest it flat for 15 minutes. Bydureon BCise pen can be kept at room temperature for up to 4 weeks.



Figure B

B. Check the expiration date (labelled EXP) printed on the pen label.

Do not use the pen past the expiration date.



Figure C

C. Wash your hands.

D. Choose your injection site.

In either your stomach, thigh, or back of the upper arm, see Figure D.

Each week you can use the same area of your body, but choose a different injection site in that area of your body.

Clean the area with an alcohol swab.

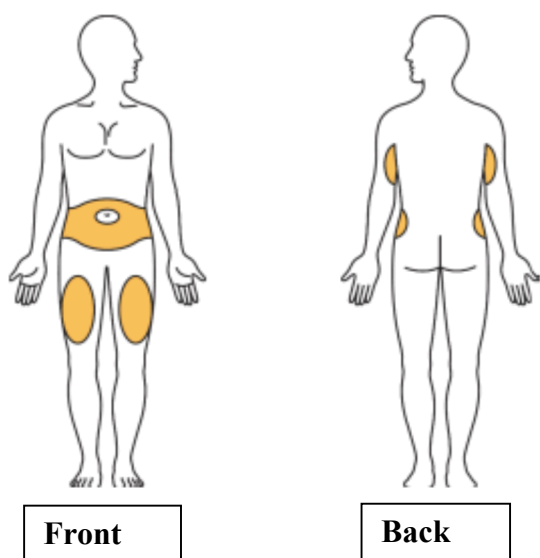

Figure D

STEP 2: Mix the medicine

A. Look in the window.

You may see white medicine along the sides, bottom or top. This means the medicine is not mixed evenly.

Look

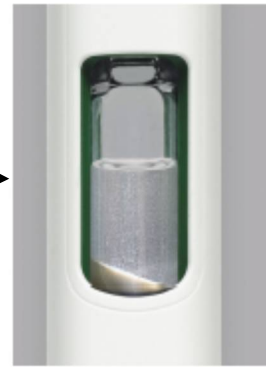

Figure E

B. Shake the pen hard,

in an up-and-down motion, until the medicine is mixed evenly and you do not see any white medicine along the sides, bottom or top. Shake for at least 15 seconds.

Shake Hard

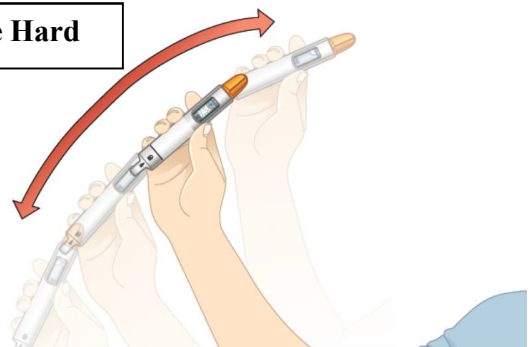
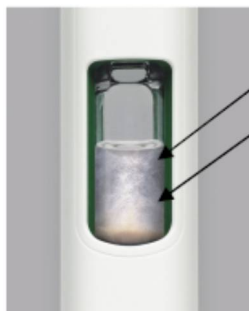

Figure F

C. Check the mix.

Hold the pen up to the light and look through both sides and the bottom of the window. If not mixed well, repeat Step 2 and check again.



NOT Mixed Well

Uneven mix
White medicine on
bottom, top, or sides



Figure G

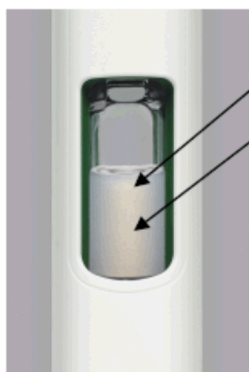

Mixed Well

Even mix
Cloudy
It's OK to see bubbles



Figure H



Do not go to the next step unless your medicine is mixed well. To get a full dose, the medicine must be mixed well and look cloudy.

If not mixed well, continue to shake hard.

STEP 3: Prepare the Pen

Important: After the medicine is fully mixed, you must complete the preparation steps **right away**, and inject to get the full dose. Do not save it to use later.

Only unlock the pen when you are ready to inject.

A. Unlock the pen.

Hold the pen up straight with the orange cap toward the ceiling. Turn the knob from the Lock to the Unlock position until you hear a click.



Figure I

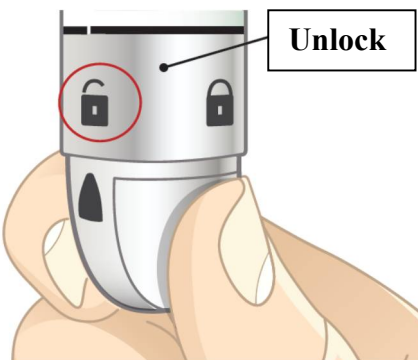

Figure J

B. While still holding the pen straight up, firmly unscrew the orange cap.

- You may need to turn the cap a few times before it loosens (if you hear clicking you are turning in the wrong direction).
- Continue holding the pen upright to prevent the medicine from accidentally leaking.
- A green shield will pop up after the cap is removed. The green shield hides the needle. It is normal to see a few drops of liquid inside the cap. **Do not** recap the pen.

Throw away the cap.

Hold **upright & firmly** unscrew



Figure K



Figure L

Removed Cap



Figure M

Green shield **pops up**

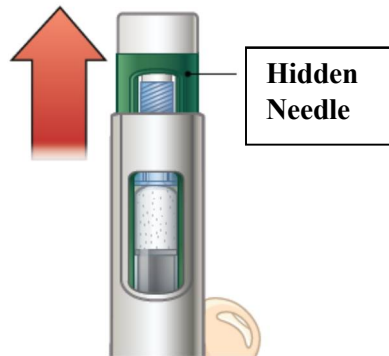

Figure N

STEP 4: Inject the Dose

A. Inject and hold:

- Push the pen against your skin. You will hear a “click” when the injection begins.
- Keep holding the pen against the skin for 15 seconds. This is to make sure you get the full dose.

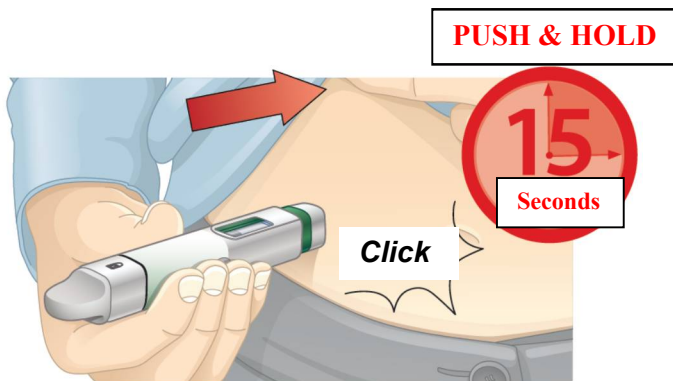

Figure O

B. Make sure you received your full dose.

After you receive your injection, you will see an orange rod in the window. After you lift the pen from your skin, the green shield will move back up to lock over the needle. See the Common Questions & Answers for what to do if you do not see the orange rod after injection.

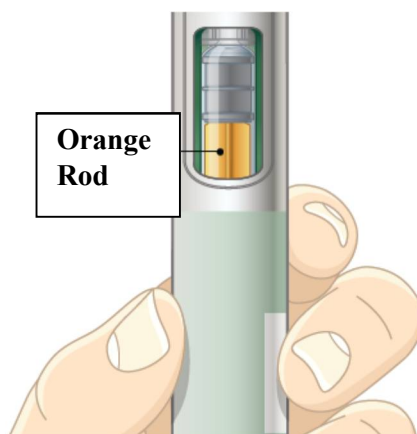

Figure P

C. Disposal.

Properly dispose of your pen right away after use, as instructed by your doctor, pharmacist or diabetes nurse.

You will need a puncture-resistant container that:

- is large enough to hold the entire pen,
- has a lid,
- does not leak,
- is properly labelled to warn of hazardous waste inside the container.

You may use a biohazard container, another hard plastic container, or a metal container.

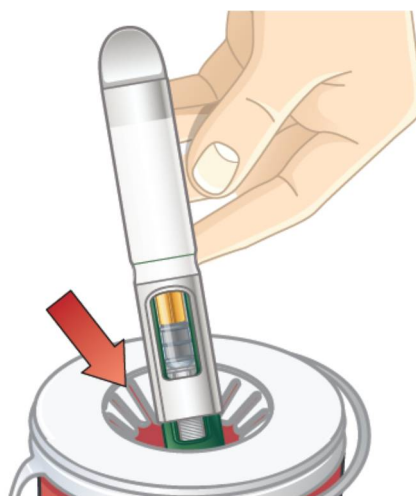

Figure Q

Common Questions and Answers

1. Where is the needle?

The needle is attached to the pen and covered by the orange cap.

When you unscrew the orange cap, the green shield keeps the needle covered until you inject.

For more information, please see Figure N in Step 3B in the Instructions for the User.

2. How do I know if the medicine is fully mixed?

After shaking the pen, look through both sides of the window. You should not see any white medicine along the bottom, top, or sides. If you see white medicine, it is unmixed. To mix, shake the pen hard until the white medicine is no longer on the bottom, top, or sides. The medicine should look even throughout (see pictures in Figure G and Figure H, Step 2C).

3. Why do I need to hold the pen upright while removing the orange cap?

Holding the pen with the orange cap straight up helps prevent the medicine from leaking. It is normal to see a few drops of medicine inside the orange cap after you unscrew it.

4. Why should I inject my medicine right away after mixing it?

If you do not inject your medicine right away after mixing, the medicine may separate, and you will not get your full dose. You can re-mix your medicine if your pen is in the locked position. However, after you unlock it, you must complete the preparation steps right away and inject to get the full dose. You cannot save it for later use.

5. How do I know I gave myself the full dose of medicine?

To be sure you get your full dose, press and hold the pen against your skin.

You will feel the needle go into your skin. Hold the needle against your skin for 15 seconds. This will allow enough time for all the medicine to go from the pen to under your skin. After removing the needle, look for the orange rod in the window as a way to tell that the dose has been given. If the orange rod does not appear, contact the local representative of the Marketing Authorisation Holder (see section 6 of the Package Leaflet for a list of contacts by country).

6. Why should I store my pen flat in the refrigerator?

Pens stored vertically (with the needle up or down) are more difficult to mix. The medicine can still be fully mixed but it will take more shaking and more time.

7. How do I dispose of my Bydureon BCise pen?

Do not throw away the pen in your household waste. You will need a puncture-resistant container that is large enough to hold the entire pen. Be sure the container has a lid. You may use a biohazard container, another hard plastic container, or a metal container. A container is not included in the carton.

Do not recycle the container with used pens. Ask your pharmacist how to safely throw it away. Do not throw the container in your household waste.

8. What if the device malfunctions and I cannot unlock it?

Review the Instructions for the User Step 3 to confirm the order of operations, then contact the local representative of the Marketing Authorisation Holder (see section 6 of the Package Leaflet for a list of contacts by country). Do not try to unlock with excessive force or tools.

9. What if the device malfunctions and I cannot remove the orange cap?

Review the Instructions for the User Step 3 to confirm the order of operations, also confirm that the knob is fully in the unlocked position, then contact the local representative of the Marketing Authorisation Holder (see section 6 of the Package Leaflet for a list of contacts by country). Do not use tools or try to force the cap off.

10. Where to learn more about Bydureon BCise pen

- **Talk with your doctor, pharmacist or diabetes nurse**

- **Read the Package Leaflet carefully.**

How to Store Bydureon BCise pen

- Store flat in the refrigerator between 2°C to 8°C.
- Each pen can be kept at room temperature not to exceed 30°C for no more than a total of 4 weeks, if needed.
- Store in packaging provided to protect from light until you are ready to prepare and use your dose.
- Do not use past the expiration date. The expiration date is labelled EXP.
- Keep the pen clean and away from spills.