

PAGES 1-5

ANNEX I Essential requirements

SECTION 1 General conditions

PARAGRAPH 1.2.1

SUBJECT **Boiler body / forced draught burner matching**

“The technical instructions intended for the installer must contain all the instructions for installation, adjustment and servicing required ensuring that those operations are correctly performed and that the appliance may be used safely. In particular, the instructions must specify:

...

- *for forced draught burners and boiler bodies intended to be equipped with such burners, their characteristics, the requirements for assembly, to assist compliance with the essential requirements applicable to finished appliances and, where appropriate, the list of combinations recommended by the manufacturer.”*

Question

Boiler bodies are covered by the definition of heating bodies mentioned in the Directive. How should the manufacturer(s) of the forced draught burner and boiler body provide the information referred to in the last indent of Essential Requirement 1.2.1 to ensure safe boiler body/burner matching?

Discussion

Forced draught burners and the boiler bodies to be equipped with such burners when placed on the market separately need to be matched safely.

Normally, a forced draught burner is fitted to the boiler body at the place of putting into service by the installer.

In order to make sure that the combination will be in conformity with the Essential Requirements, manufacturers of the forced draught burners and boiler bodies must specify adequate information to ensure the burner/boiler matching can be carried out safely.

The manufacturer of forced draught burners, who markets the burners separately, must:

- assure that the burners are tested and certified on the basis of use of a test rig which simulates the boiler bodies, and
- either indicate in the instructions for installation the necessary technical information for matching the burners to the boiler bodies,
- or on the basis of the technical information, where appropriate, draw up a list of recommended combinations.

This matter is covered by harmonised standard EN 676.

This guidance is for information only; it has no formal status

Reference: 90/396/EEC “Gas appliances directive” O.J. L 196, 26.07.90, p. 15

Source of guidance document: GADAC

Doc. Number	Rev. Number	Approved by GADAC	Approved by WG-GA	Withdrawn
B3	1.1	10/2004	02/2005	

The manufacturer of boiler bodies has two options:

First option (restricted use of burners)

- To identify the specific forced draught burners which may be used with the boiler body; and
- To list the identified burners in the instructions.

Second option (separate market for boiler bodies)

- To specify in the instructions the interface requirements for the forced draught burner.

Conclusion

Manufacturers of forced draught burners and boiler bodies shall provide sufficient instructions either specifying the boiler body and burner combinations, or provide sufficient interface information to allow pairs to be matched safely.

The Annex gives detailed information on a procedure for ensuring safe boiler body / forced draught burner matching.

Doc. Number	Rev. Number	Approved by GADAC	Approved by WG-GA	Withdrawn
B3	1.1	10/2004	02/2005	

ANNEX1 General

- The burner shall be suitable for combination with boiler bodies, which can be assured by fulfilling the requirements of harmonised standard EN 676.
- The boiler body shall be suitable for combination with a burner, which can be assured by fulfilling the requirements of EN 303-1.
- The combination of boiler body and forced draught burner shall fulfil the essential requirements of the GAD, which can be assured by testing at least one assembly (a boiler body with a forced draught burner) according EN 303-3.

2 Options2.1 List

The manufacturers establish a list of recommended combinations in accordance with Essential Requirement 1.2.1 (last indent). This list shall be based either on tests or on criteria set out in the Guidance Sheet and this Annex to it.
The installer may select the appropriate combination of boiler body and burner by reference to the list.

2.2 Technical instructions

The technical instructions shall include the necessary information to permit the installer, responsible for the installation, and the commissioning of the finished appliance, to verify that when installed it does meet the Essential Requirements.

3 Procedure

The procedure mentioned hereafter will be part of the manufacturer's instruction for the installer.

3.1 Criteria for matching a boiler body/burner

The criteria mentioned hereafter do not apply to assemblies designed as units and tested as such. Such an assembly will be marketed as a complete boiler (unit).

- 3.1.1 The minimum dimensions of the combustion chamber shall not be smaller than the values specified in diagram 1.

Doc. Number	Rev. Number	Approved by GADAC	Approved by WG-GA	Withdrawn
B3	1.1	10/2004	02/2005	

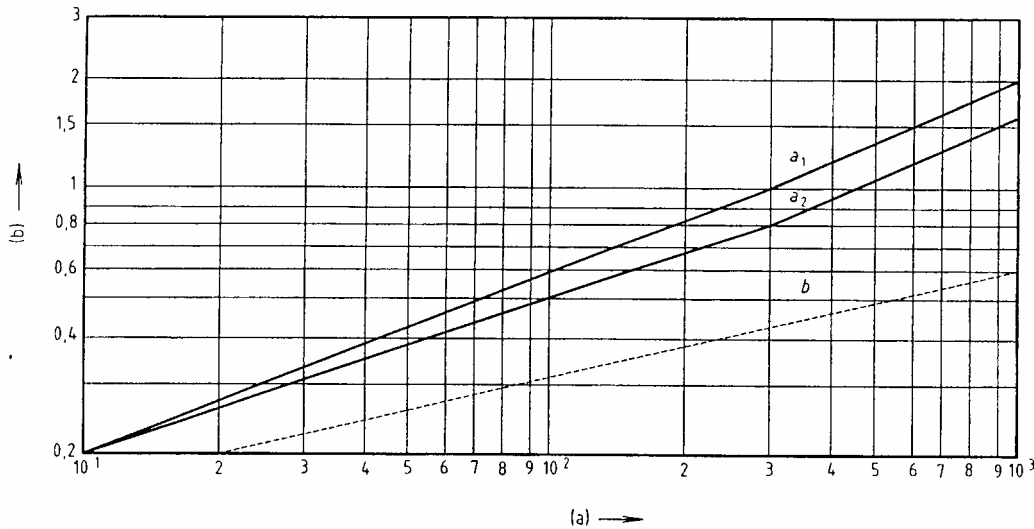

Diagram 1: Minimum dimensions of the combustion chamber

whereby (see EN 303-3:1998):

(a) = Nominal useful output P_n in kW

(b) = Diameter and length of the combustion chamber in m

the dimension "a" is the distance from the deflector plate of the burner up to the opposite wall of the combustion chamber.

- a_1 = Minimum length for combustion chamber with direct flame
- a_2 = Minimum length for combustion chamber with flame reversal

For a combustion chamber designed for reverse flame and with a heat input greater than 300 kW, the length "a" can be reduced by 20%.

For boilers with a heat input between 10 kW and 300 kW the reduction of "a" occurs proportionally to the heat input between 0% and 20%.

the dimension "b" is the diameter of the circular combustion chamber or the minimum sectional dimension in the case of a non circular combustion chamber.

- 3.1.2 The resistance of the combustion chamber corresponding to the nominal heat input shall be in accordance with the working diagram of the burner, as defined in EN 676.
- 3.1.3 The operation mode of the burner (on/off, two stage or modulation) shall be in accordance with the instructions given by the boiler body manufacturer.
- 3.1.4 The minimum heat input of the burner shall not be set to a lower value than the minimum heat input, declared by the boiler body manufacturer.

Doc. Number	Rev. Number	Approved by GADAC	Approved by WG-GA	Withdrawn
B3	1.1	10/2004	02/2005	

3.2 Technical documentation

3.2.1 The boiler body manufacturer shall specify in accordance with EN 303-1 and EN 303-3 the following data:

- nominal heat input;
- the operation mode for which the boiler body has been designed (on-off, multistage, modulating). The minimum heat input, below which value the burner may not operate in case of boiler bodies intended to be fired by a multistage or modulating burner;
- the flow resistance of the combustion chamber ($\lambda = 1,2$) at nominal heat input;
- the type of combustion chamber (direct evacuation or reversed combustion);
- the length "a" of the combustion chamber, see figure 1;
- the diameter or, in case of a non circular combustion chamber, the minimum sectional dimension;
- the burner penetration "x" and the geometry of the assembly flange, see figure 1;
- relevant warnings (operation).
- temperature of combustion products, CO₂ (or O₂) and CO values.

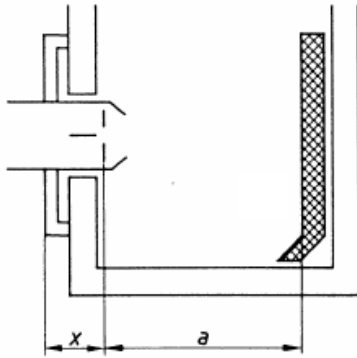

a: length of combustion chamber with or without fire brick
x: distance between burner flange and nozzle, given by the manufacturer

Figure 1 Burner - boiler assembly

3.2.2 The burner manufacturer shall specify in accordance with EN 676 the following data:

- maximum and minimum heat input;
- the working diagram;
- the dimensions of the burner head;
- the burner penetration (x) and the geometry of the assembly flange, see figure 1;
- the connection dimensions;
- relevant warnings (operation).

3.3 Test report

The installer shall draw up a test report containing checks and adjustments related to the boiler body and the burner specifications and the adjustments carried out.

Doc. Number	Rev. Number	Approved by GADAC	Approved by WG-GA	Withdrawn
B3	1.1	10/2004	02/2005	

3.3.1 The installer shall indicate:

- the address and name where the assembly is installed;
- the name and type of the certified boiler body to EN 303-1/303-3;
- the name and type of the certified burner to EN 676/303-3;
- the maximum and minimum heat input declared by the manufacturer for the boiler body and for the burner;
- the operation mode for which the boiler body has been designed (on-off, multistage, modulating);
- the flow resistance of the combustion chamber declared by the boiler body manufacturer;
- the type of combustion chamber (direct evacuation or reversed combustion);
- the length (a) of the combustion chamber as indicated in figure 1;
- the diameter or minimum sectional dimension in case of a non circular combustion chamber;
- the burner penetration (x) into the combustion chamber as indicated in figure 1;

3.3.2 The installer shall make the following adjustments:

- the heat input, in accordance with the instructions of the manufacturer of the burner;
 - the minimum heat input in case of multistage or modulating burners;
 - the ignition rate of the burner in accordance with the instructions of the manufacturer of the burner;
 - the combustion air
- and shall calculate the global efficiency (Siegert formula).

After the adjustments the installer shall note:

- the heat input;
- the minimum heat input;
- the ignition rate;
- temperature of the combustion products as well as the CO₂ (or O₂) and CO values These values shall be in accordance with those given by the manufacturer;
- the ambient temperature

Doc. Number	Rev. Number	Approved by GADAC	Approved by WG-GA	Withdrawn
B3	1.1	10/2004	02/2005	