

Developing DC transmission networks using DC/DC transformers

Dragan Jovcic, University of Aberdeen

October 2010

1. Introduction

1. State of technology

The planned large-scale renewable energy development in the North and Baltic seas will require a new subsea power transmission network which will enable power transfer to the European countries. Also the proposed transmission network will improve power exchange between EU countries and strengthen the overall EU transmission system.

Because of the large geographical distances, large power levels involved, and the use of cable conductors, the new subsea transmission grid must be based on DC transmission technology. Conventional overland networks are dominated by AC technology but its application in cable systems is hampered by serious reactive power related drawbacks.

There are large number of HVDC (High Voltage Direct Current) links worldwide which use overland interconnectors with power ratings of over 3GW and cable systems with power limits of around 1GW. However all existing HVDC system operate as point-to-point interconnectors. There are no operational multiterminal HVDC systems or high-power DC transmission networks. The current state of technology does not support cost-effective and reliable connections to high-power DC lines. i.e. power take-off or injection are not possible along the DC lines.

The main technical challenges with DC networks are

1. DC fault isolation. A fault on one grid segment should not lead to voltage collapse on the whole grid. The interruption of fault current is necessary in order to isolate a faulted line or unit in a DC grid. This function will prevent fault spreading and enable normal operation of the remaining DC grid. This function is essential in achieving DC grid security/reliability comparable with the existing AC grids.
2. DC voltage stepping. Increasing voltage levels reduces transmission losses. When power is distributed to low-power users the voltage is reduced to reduce costs and for safety reasons. There is also another important reason for DC/DC conversion. There are already around 9 HVDC lines in the North and Baltic seas (operating at a range of DC voltage levels) built by different manufacturers, and DC/DC conversion will be required to interconnect these lines in the new DC grid.

The above two functions (fault isolation and voltage stepping) are readily achieved with AC networks, using two different components. The faults are isolated using AC circuit breakers which take advantage of natural zero-crossings with AC currents. The conventional iron-core AC transformers achieve efficient voltage stepping utilising changing magnetic fields induced by naturally changing AC voltages. These two components have become well developed at wide range of powers in the power industry. They utilise only mechanical, passive components and their costs and losses are moderate.

2. The Electronic DC substation concept

Figure 1 shows the proposed concept for developing DC networks, which has been studied by the research team at University of Aberdeen. The figure shows the novel DC substation (DC/DC converter) which enables connection of an offshore wind farm to the subsea HVDC link between UK and Norway (this HVDC link is under study). The connection of offshore wind farm is mid-point along the DC line, but it can be located at any other distance. There are several important aspects of this DC substation technology:

- 1) The DC substations are being studied worldwide and the University of Aberdeen has developed one technology concept. Regardless of the particular inner circuits, the DC substation will be based on Power Electronics. This implies that costs and losses will always be higher, compared with similar-size AC transformers (or AC substations). The costs and losses will be comparable to other converter systems, like AC/DC converters. Considering the long experience with HVDC, the electronic DC substation should have high reliability and comparable with traditional AC substations.
- 2) The DC substation will be multifunctional and could replace several components in traditional AC substations. The Aberdeen technology simultaneously achieves:
 - a. DC voltage stepping. It takes the role of an AC transformer in AC grids, with the added benefit that the stepping ratio is readily controlled.
 - b. DC fault isolation. It takes the role of an AC Circuit Breaker in AC grids, with the added benefit of faster opening/closing and minimum maintenance (no wearing of moving parts).
 - c. DC power flow regulation. The capability to precisely regulate power flow in each DC line might be very important in more complex DC grids. It will lead to optimal utilisation of transmission assets, which has been significant issue in traditional AC networks. In AC grids there is no possibility of power regulation at inner network nodes, and this frequently creates line overloading and loop flows.
- 3) Responses will be very fast and controllability will be excellent. The power electronics components inherently possess responses which are 1-2 orders of magnitude faster than mechanical systems.

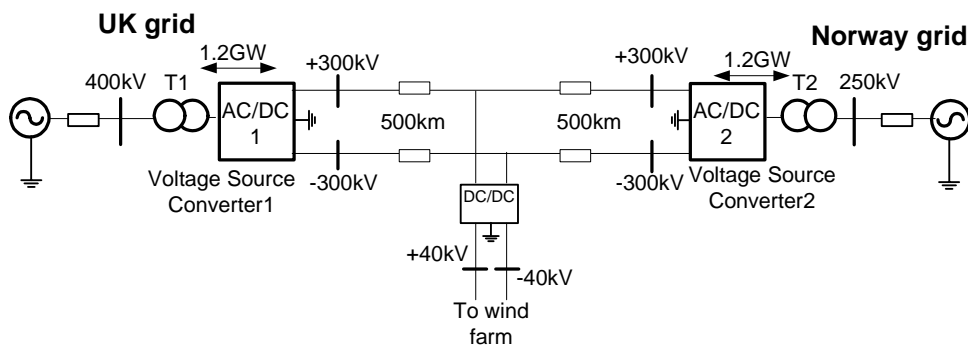

Figure 1. A $\pm 300\text{kV}$ HVDC line (UK-Norway) with a mid-point connection to medium voltage $\pm 40\text{kV}$ wind farm collection grid.

The topology in Figure 1 assumes a single DC/DC converter placed only at the connection to a low-voltage feeder. Such concept would not be able transmit wind farm power if there is a fault on main UK-Norway HVDC line (additional DC/DC converters are needed). The Figure 2 shows the DC network concept based on multiterminal DC substations which avoids such issue. The multiterminal station has lower costs and losses compared with placing multiple two-terminal DC/DC converters (from Figure 1) on each DC line. The basic properties of multiterminal DC substation are:

- 1) It has capability of connecting multiple (4 in Figure 2) DC lines of different voltage levels. In general there are no limitations on stepping ratios but high ratios have an impact on efficiency.
- 2) It has capability of isolating (interrupting) faults on any of the DC terminals. A fault on any external DC line will be internally interrupted in the DC substation. This implies that the power flow between the remaining DC terminals is unaffected.
- 3) It can regulate power independently on each DC terminal.

It is noted that the multiterminal DC substation is considerably more complex than two-terminal units and that there is need for much more research on optimisation.

It is clear that the above DC grid concept will be fundamentally different from the conventional high-power AC networks. Because of multifunctional DC substations, the design, control and operation of DC grids will require novel methods and approaches. The recent research has proposed DC grid control methods and detailed simulation studies have demonstrated feasibility of complex DC networks using electronic DC substation concept. With the expectation that electronic DC substations become industry-accepted, it is believed that high-power DC networks will be realistic and that their reliability and security will be comparable with the traditional AC networks.

The traditional AC networks, and the power transmission industry, are centred around electro-mechanical and mechanical machines. Since the proposed DC networks will be built around high-power electronic units a significant shift in the power industry will be required.

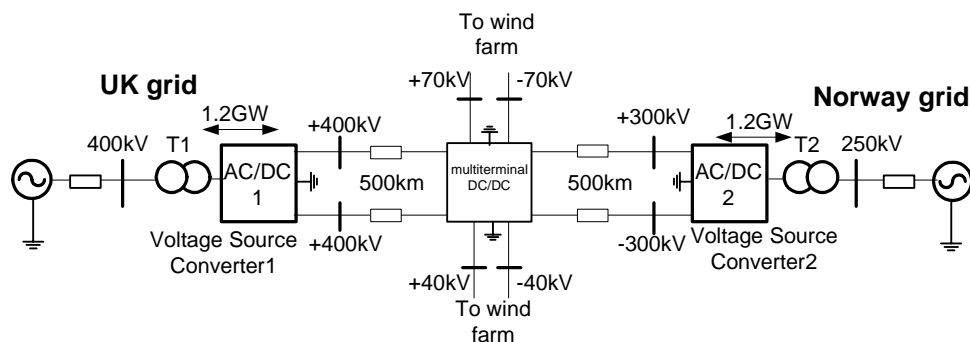

Figure 2. A multiterminal DC substation connecting four DC lines ($\pm 400\text{kV}$, $\pm 300\text{kV}$, $\pm 70\text{kV}$ and $\pm 40\text{kV}$).

3. High-Power DC/DC converter based on resonant principles

There has been a lot of research worldwide on medium/high power DC/DC conversion but none of the proposed topologies have been applied commercially in the high-power range. The DC/DC systems invariably use power electronics components with various inner circuits, and the primary challenges are linked with the efficiency, fault responses and costs.

The researchers at University of Aberdeen have developed a family of high-power DC/DC converters for the application with DC grids, shown in Figure 1. These converters differ from traditional approaches through utilisation of resonant circuit principles. A DC/DC converter based on a resonant circuit brings the following advantages:

- 1) The passive circuit is based solely on capacitors and inductors (no iron-core AC transformers). The weight and size are significantly lower than comparable AC transformers (typically 3-8 times).

- 2) Any stepping ratio is achievable (limited by the rating of electronics). The stepping ratio is controllable.
- 3) Resonant converters have inherent fault isolation capability. In case of faults on the output DC terminal (either high or low voltage external DC line), the converter naturally reacts to reduce power on the input terminals, and responds like open circuit. This implies that there is no fault propagation through the converter, and the DC voltage is unaffected on the input side. It is noted that such response is achieved without any control action.
- 4) The power flow control is possible and the controllability is linear.
- 5) The converter uses thyristors, which are highly reliable and have low cost and losses.

The researchers have made initial estimations on the DC/DC converter costs and losses. Neglecting marination costs (additional costs for installing converters offshore) the DC substation in Figure 1 is compared with a Voltage Source Converter AC/DC converter in the same figure:

- The costs of DC/DC converter will be 100%-150% of the costs of a similar rated VSC AC/DC converter.
- The losses will be 100%-200% losses of similar rating VSC converter assuming modest stepping ratios (2-4). With higher stepping ratios (below 10) the losses may increase to 300% of VSC converter losses.

Note though that a VSC AC/DC is a converter for different application and can not be directly compared in terms of functionality.

4. The research and development projects at University of Aberdeen

At the time of writing (October 2010), there are several research and demonstration projects on DC networks being undertaken at the University of Aberdeen Power laboratory. The most important projects are summarised below.

- 1) Development of a 30kW DC/DC 900V/220V prototype (Scottish Enterprise funded, April 2010-September 2011). This project has funded IP protection, 30kW demonstration prototype, market research and commercialisation activities. The Market Research has given extremely positive views and interest from industry worldwide. A very low power prototype (100W) has been built and tested. The 30kW bidirectional prototype has two terminals like the DC substation in Figure 1, and it is currently in the assembly stages with verification testing expected in December 2010. It is planned to set up a University spin-out company to commercialise this technology in Summer 2011. We are currently looking for industrial partners to develop demonstration projects in 2011/2012.
- 2) Development of 900V DC network test rig (EPSRC funded, April 2010 - March 2013). This project aims to develop a scaled-down, 30kW, $\pm 450V$, 5-terminal DC network at the University research laboratory. This test rig will emulate features of a high-power DC transmission network, using kV-size components, but at safer and affordable power levels. There will be 3 DC/DC converters providing multiple DC voltage levels in this network. The network will facilitate research on advanced DC/DC converter concepts like the multiterminal DC substation in Figure 2. We will also study DC/DC converter interactions with AC/DC converters and overall DC grid control and operation. It will also facilitate studies of interconnection of various DC (renewable) sources or loads to future DC grids.

Bibliography:

AU Power Systems group web page: <http://www.abdn.ac.uk/~eng727/index.html>

- [1] **D Jovcic** and B.T Ooi, "Tapping on HVDC lines using DC transformers" *Electric Power Systems Research, Elsevier, EPSR-D-09-00141*, in print.
- [2] **D Jovcic** and B.T Ooi, "Theoretical aspects of fault isolation on DC lines using resonant DC/DC converters" *IET Generation Transmission and Distribution, GTD-2010-0274.R1*. in print.
- [3] **D Jovcic** and B.T Ooi, "Developing DC transmission network using DC transformers" *IEEE Transactions on Power Delivery, Vol. 25, issue 4, October 2010, pp 2535-2543*.
- [4] J Robinson, **D Jovcic** and G Joos, "Analysis and Design of an Offshore wind farm using MV DC grid" *IEEE Transactions on Power Delivery, Vol. 25, issue 4, October 2010, pp 2164 -2173*.
- [5] **D.Jovcic**, "Bidirectional high power DC transformer" *IEEE Transactions on Power Delivery Vol. 24, issue 4, October 2009, pp 2276-2283*.
- [6] **D.Jovcic** "Step-up DC-DC converter for MW size Applications" *IET Power Electronics, Vol. 2, issue 6, November 2009, pp 675-685*.