

Seismic Energy Dissipation and Damage Control of Building Structures in Recent Years

**Xilin Lu, Ying Zhou,
Huanjun Jiang and Wensheng Lu**

**State Key Laboratory of Disaster Reduction in Civil
Engineering, Tongji University, Shanghai, P. R. China**



1. Introduction

2. TMD Control System

3. Combined Energy-dissipation System

4. Adjacent Buildings Connected by Fluid Dampers

5. Displacement-dependent Dampers

6. Combined Isolation System

7. Inter-story Seismic Isolation

8. Standards and Design Codes

9. Summary

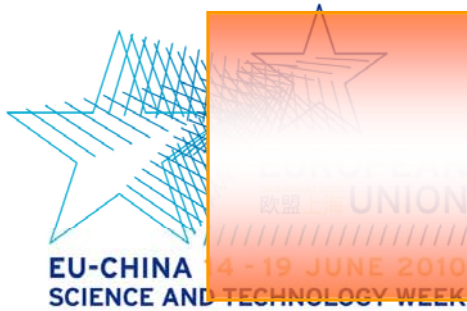

1. Introduction

- **The State Key Laboratory of Disaster Reduction in Civil Engineering** was founded in 1983. It includes **Wind Tunnel Testing Division**, **Shaking Table Testing Division**, and **Ground Motion Monitoring Division**.
- The fundamental research in this Lab. is generally combined with engineering application and aimed at the design code developments of local and national.

Introduction (cont.)

- **Research groups in Earthquake Engineering**
- **Building structures (concrete and composite)**
- Building structures (steel)
- Bridge structures
- Lifeline systems
- Ground motion and instrumentation
- Laboratory divisions

2. TMD Control System

- The system is composed of tuned mass, tuned springs, and tuned damper(**using servomotor**).

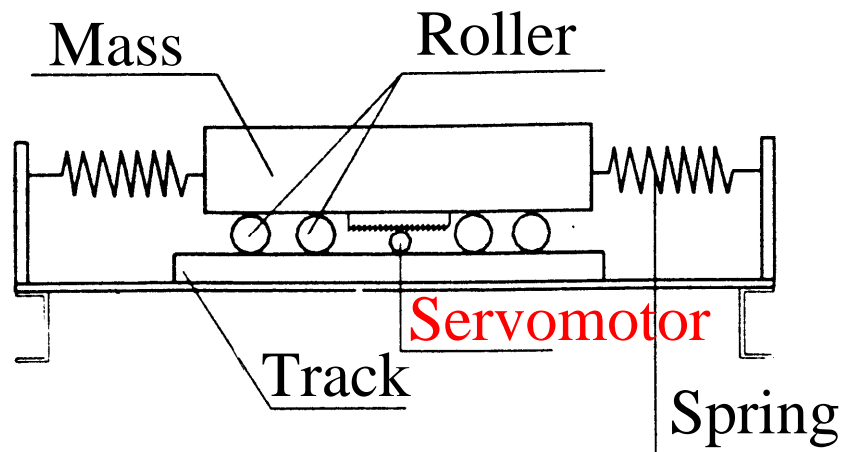

Principle of the servomotor TMD system



- **Shaking table tests were carried out on a 3-story steel frame structure equipped with this system under various seismic inputs.**



3-story steel frame model in testing

Test results vs Numerical analysis

- **The earthquake responses of the structure were reduced significantly.**
- **The damping ratio and the characteristics of frequency spectrum of the seismic input had a significant effect on the control efficiency of this system.**
- **The analytical model is developed for the tested structure, and the calculation results agree well with the test results.**

3. Combined Energy-dissipation System

SCIENCE AND TECHNOLOGY WEEK

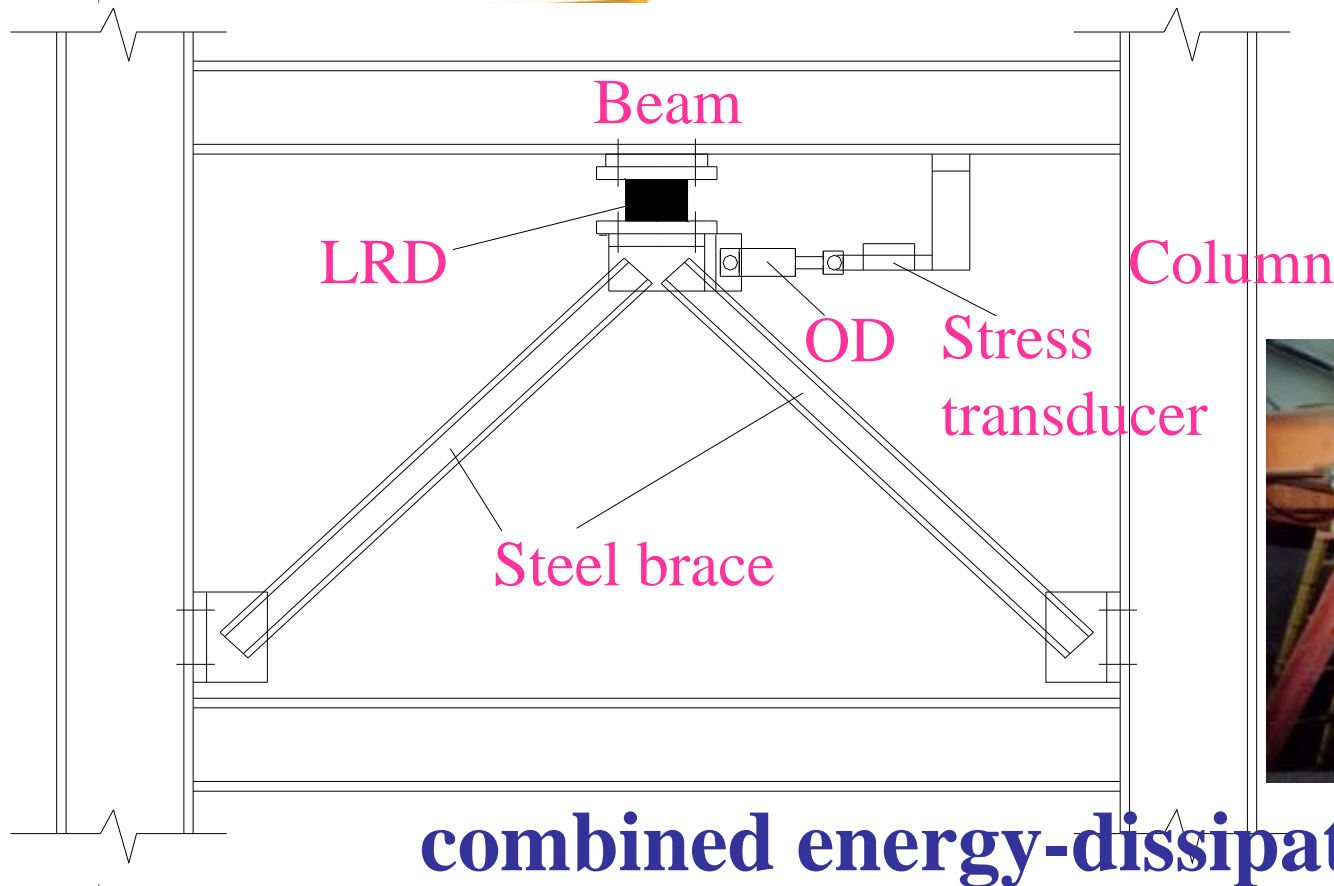

**combined energy-dissipation
system installed in a frame**



The working principle of the system

- **Under wind load or minor earthquakes, the lead rubber damper behaves elastically and oil damper provides small damping force and stiffness.**
- **Under strong earthquakes the lead rubber damper develops elasto-plastic deformation and the stiffness to the structure is decreased, and the oil damper provides larger damping force but smaller stiffness.**



- Shaking table tests were carried out on a 3-story steel frame structure **and R C. frames** with the energy-dissipation system in each story.

Application of Combined Energy-dissipation System

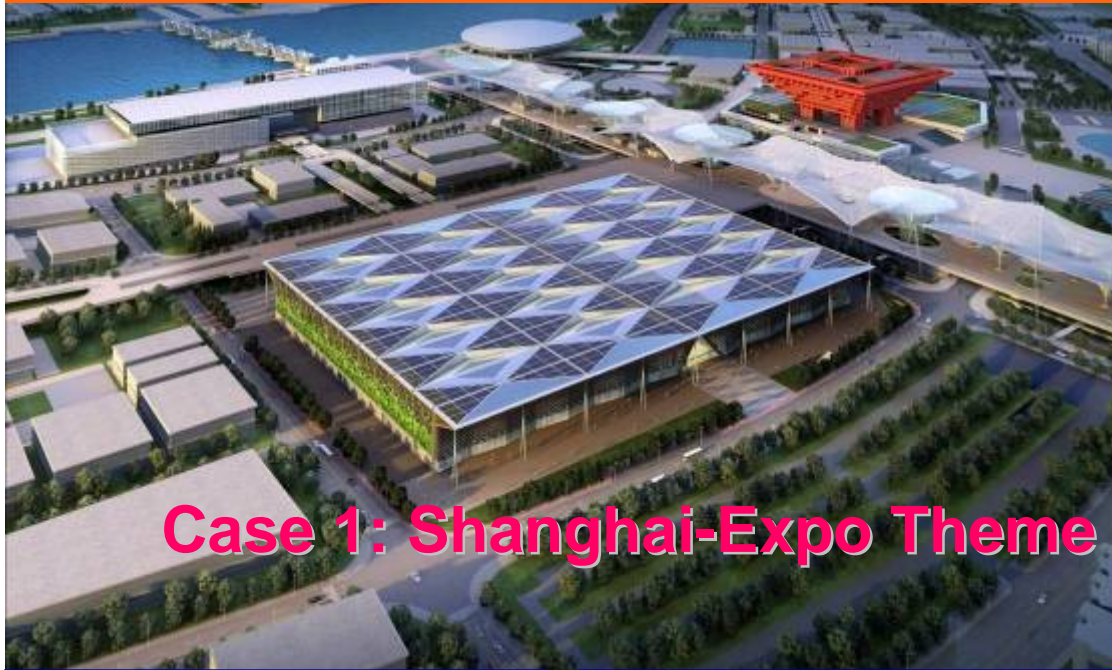

Case 1: Shanghai-Expo Theme Pavilion



Application of New Combined Energy-dissipation System



Application of New Combined Energy-dissipation System



Case 3: Office Bldg of DJY Gas Comp.

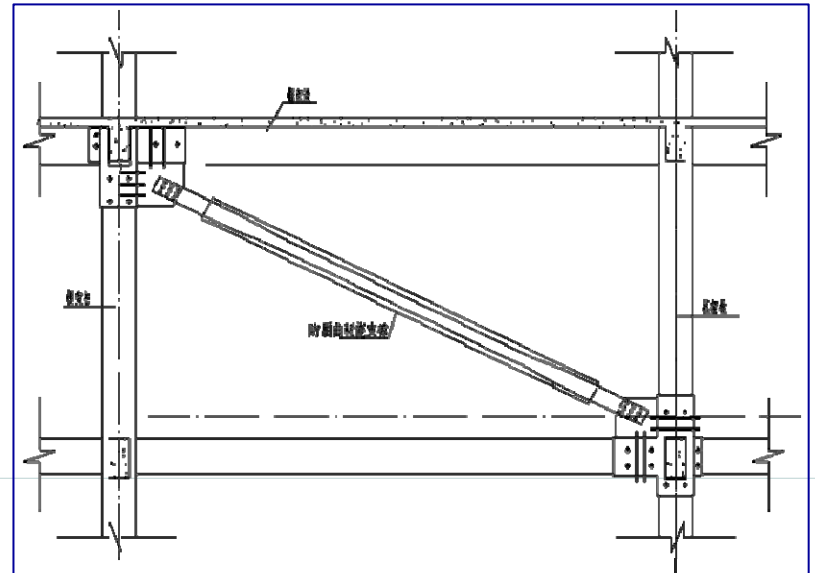
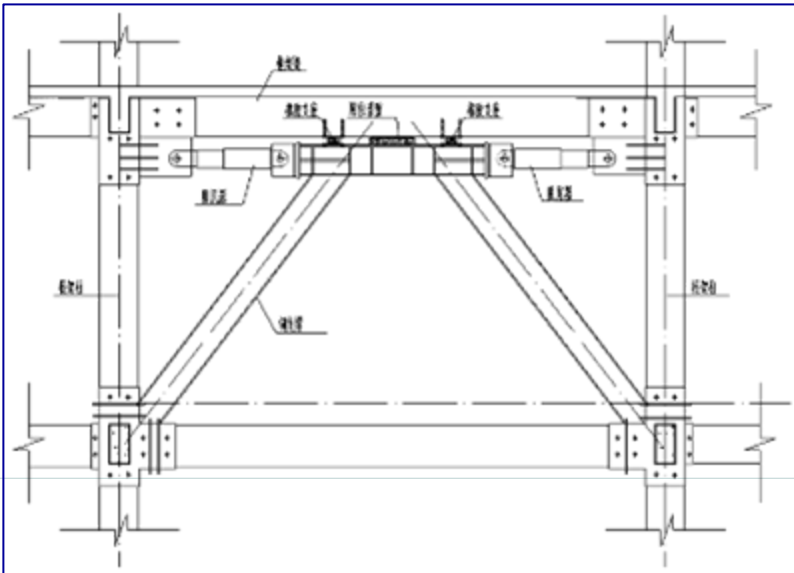

Application of New Combined Energy-dissipation System

Case 4: SH Jingan-Shixi Middle School Bldg

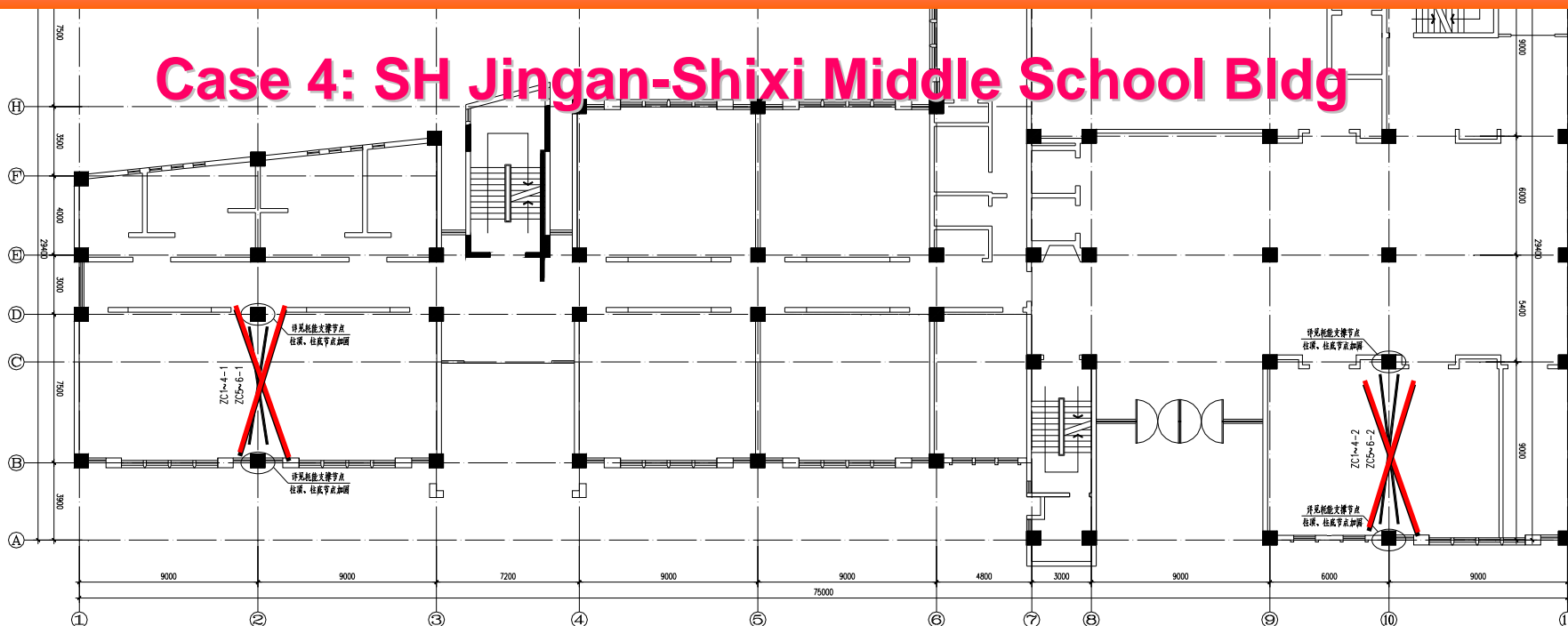

耗能器位置	间距(m)	支撑方式	耗能器数量	图例
ZC1~4-1	7.500	人字型	共4个	
ZC5~6-1	7.500	人字型	共4个	
ZC1~4-2	6.000	人字型	共4个	
ZC5~6-2	6.000	人字型	共4个	

一~六层组合耗能支撑布置图

(建筑轴网分布仅为示意)

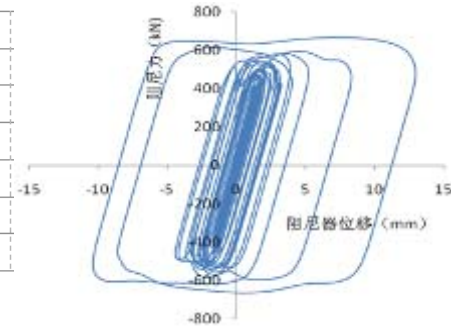
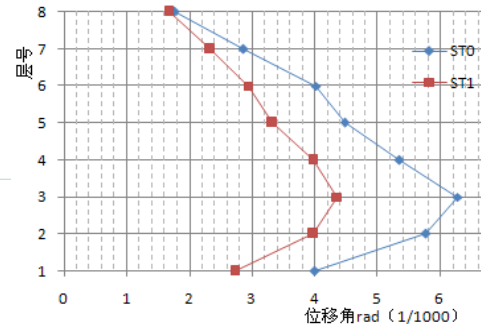
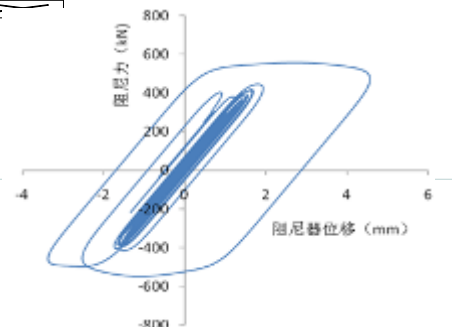
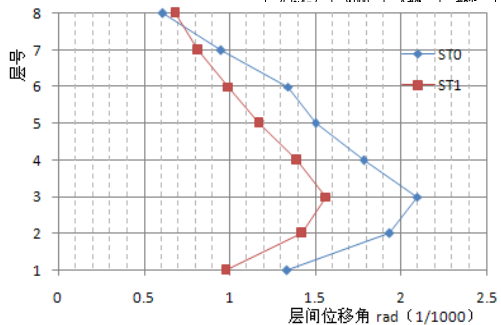

Application of New Combined Energy-dissipation System

Case 5: Shanghai Sinopec Office Building



4. Adjacent Buildings Connected by Fluid Dampers

- A series of theoretical and experimental studies were carried out to study the feasibility of linking adjacent buildings or connecting podium structures to a main building by fluid dampers to improve their seismic performance and to prevent the pounding between them.**



EU
SC



- Three connection conditions between the two frames were involved: **connected by rigid steel rods**, **connected by fluid dampers**, or **without any connections**.

Adjacent structures linked by fluid dampers in testing

Test results vs Numerical analysis

- The test results show that **the damping ratios of both buildings could be increased significantly and so their seismic responses could be reduced effectively** if appropriate parameters for the fluid dampers were selected.
- Finite element analysis shows the nonlinear earthquake responses have **good agreement with the test results.**

Application of Adjacent Buildings Connected by Fluid Dampers



Case: Shanghai Shimao International Tower

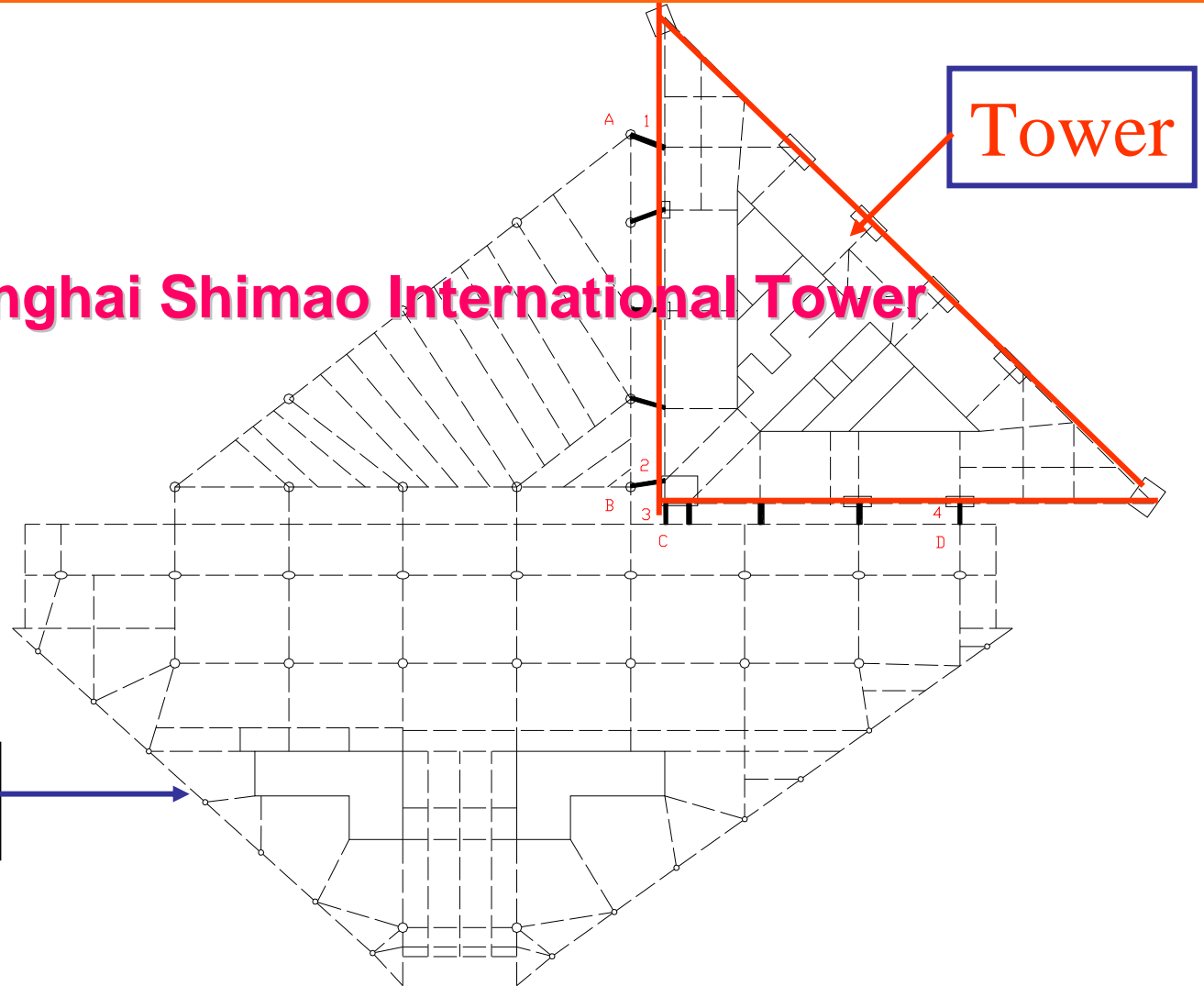

Podium

Tower



Damper Parameters

40 pieces

$F=600\text{kN}$

$\alpha=0.15$

$C=250$

Building height:

Tower: 333 m

Podium: 49.6 m

5. Displacement-dependent Dampers

Hole-added damping and stiffness (HADAS) by Taiwan



Device in testing

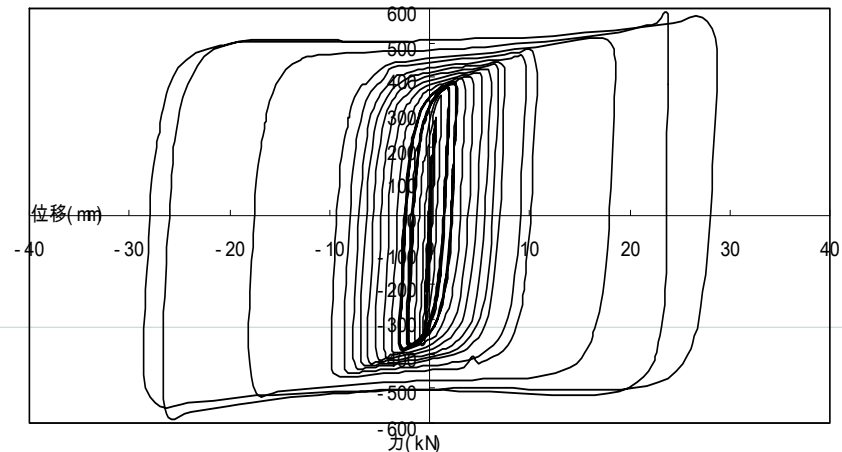
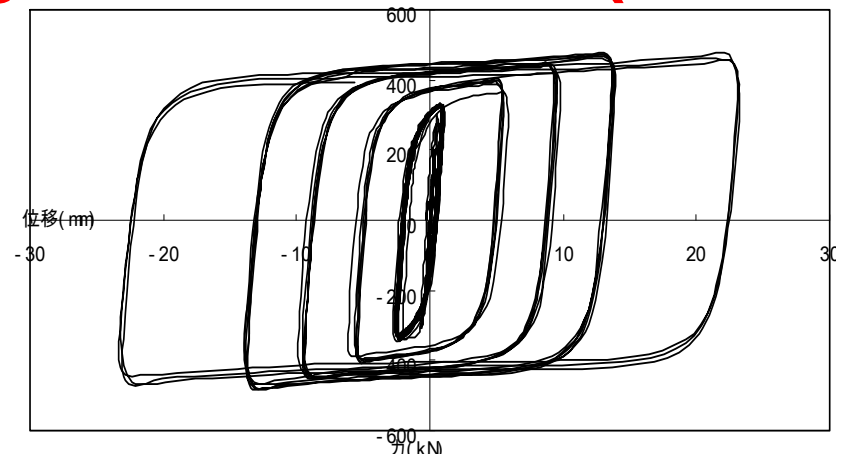

Application of Displacement-dependent Dampers

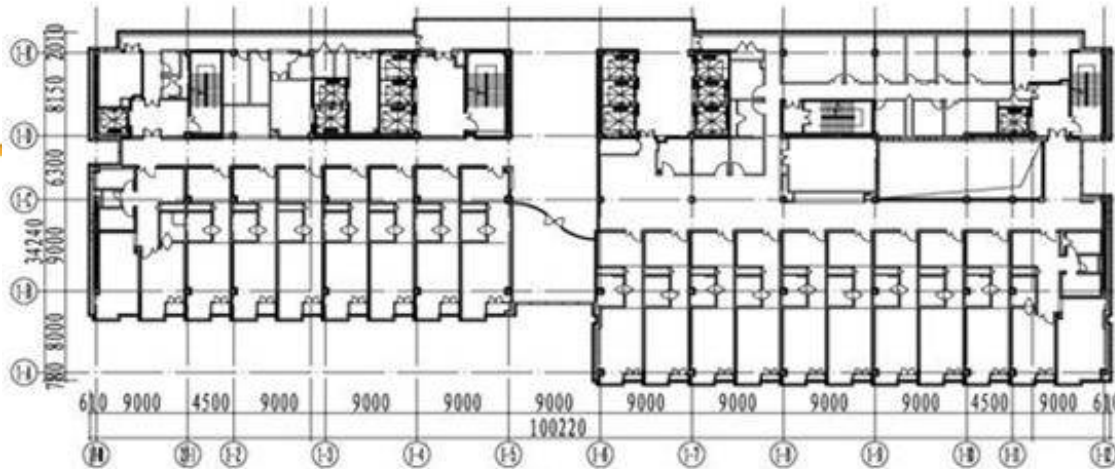

Case 1: Pekin Union Hospital



Application of Displacement-dependent Dampers

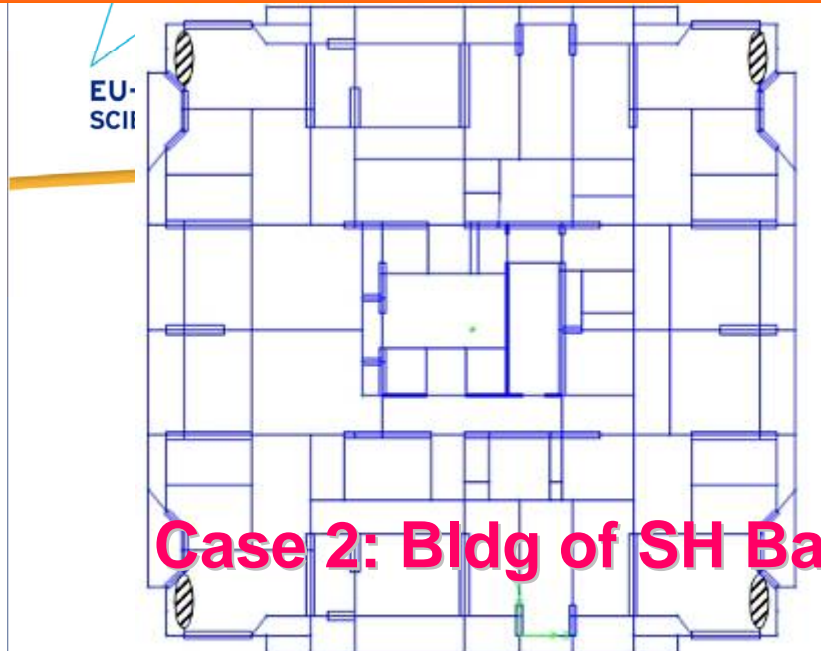

Case 2: Bldg of SH Bank of Communications

阻尼器位置

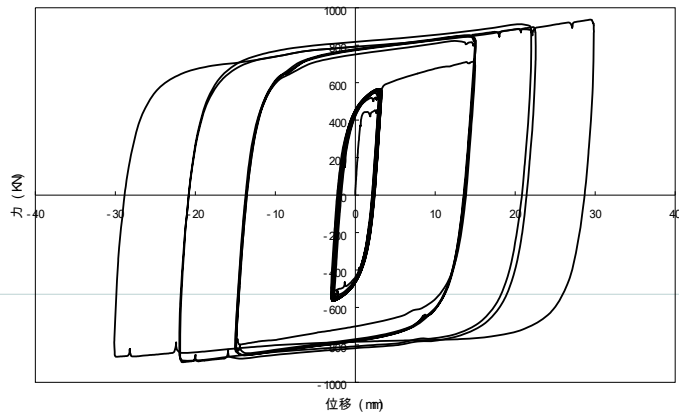

Application of Displacement-dependent Dampers

EUROPEAN
SHANGHAI 2010
UNION
欧明上海

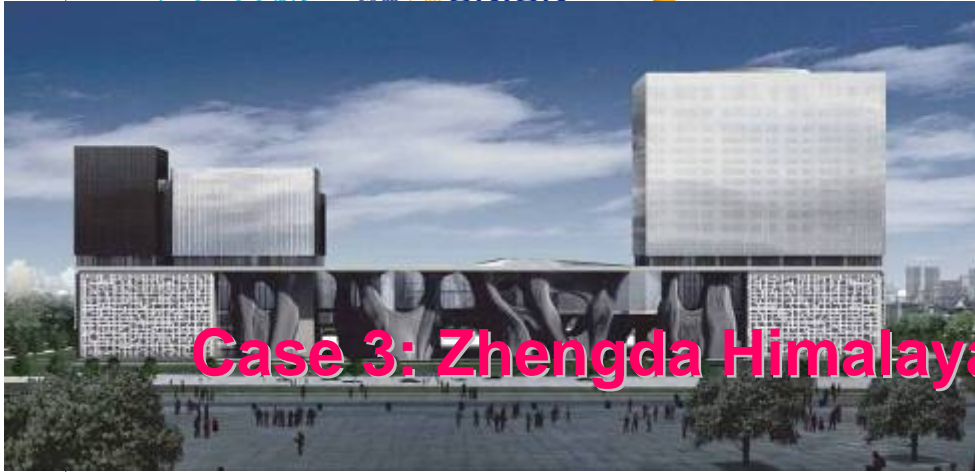

Case 3: Zhengda Himalaya Tower



Application of Displacement-dependent Dampers

EUROPEAN
SHANGHAI 2010
UNION



Case 4: Stadium at Southwest University of Science & Technology

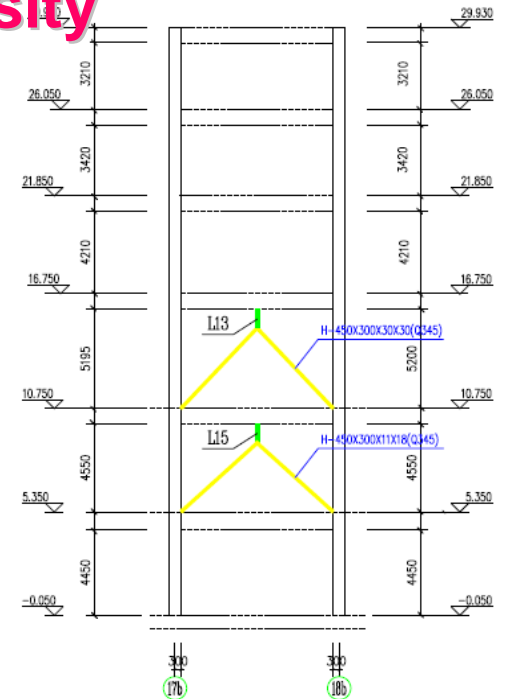
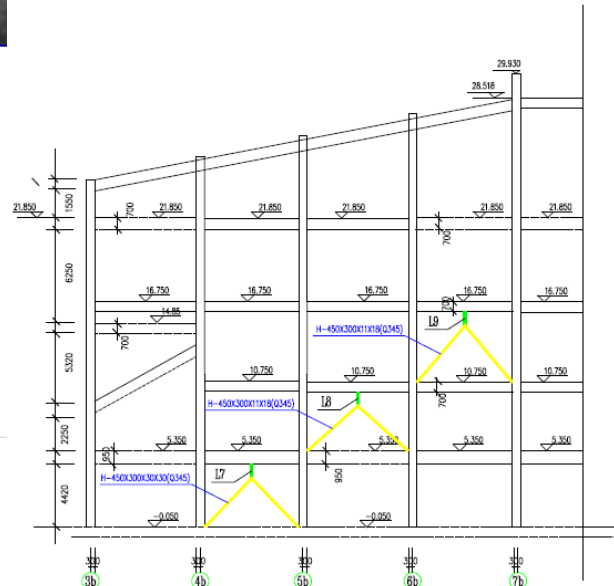
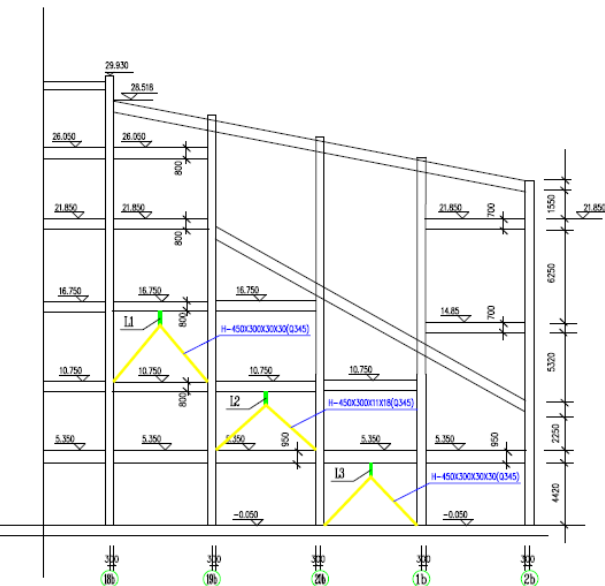

6. Combined Isolation System

ES CHINA 14-15 JUNE 2016
SCIENCE AND TECHNOLOGY WEEK

- **The isolation system for the test was composed of four rubber bearings and two frictional sliding bearings.**
- **To verify the effectiveness of this system, a 1/12-scale and three-story steel frame model was tested on the shaking table with base fixed (FIX) and isolated (SLD) separately for comparison.**

Slider isolators

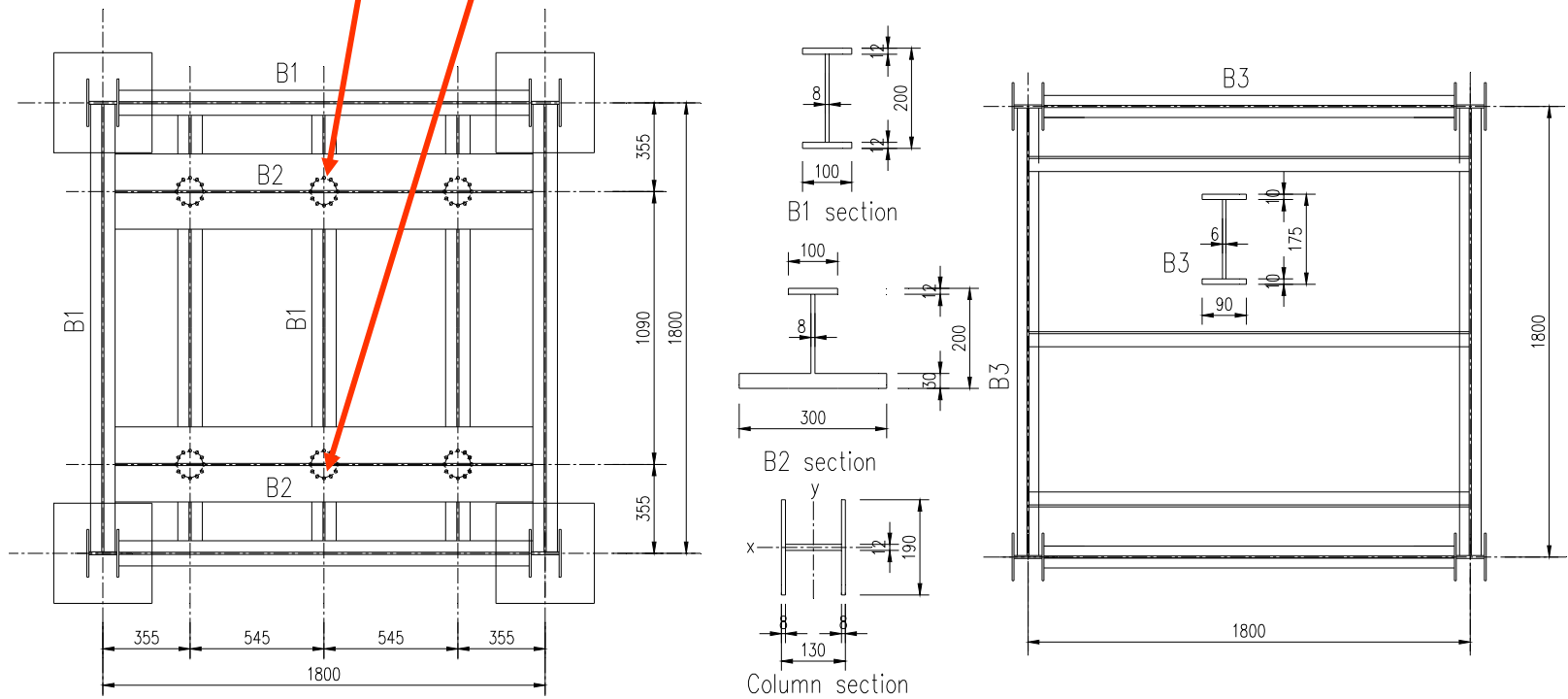

Layout of isolators and typical plan



**Base isolated
structural model**

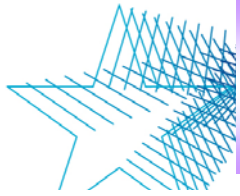

Test results summary

欧盟上海 UNION

- The effectiveness of sliding isolators is enhanced by adding rubber bearings and thereby to reduce the residual displacements to manageable levels.

The isolation system has good re-centering capability under different input level with a small residual displacement.

The vertical component of the ground motion has significant effect on the axial loads, and tension may occur in rubber bearings.



Numerical analysis

- A new simplified analytical model for the tested structure is developed by using finite element analysis.
- The superstructure and the rubber bearing are supposed to be elastic, the frictional force in the slider is simulated by the Coulomb-friction characteristics, and the damping of the rubber bearing and slider is taken as viscous damping.

Application of combined isolation system



Case: Shanghai International Circuit Press Center

**Large Span Mega-truss
Structure**



7. Inter-story Seismic Isolation

- The method of inter-story seismic isolation was developed to improve the seismic performance of existing old buildings, especially in the case of adding story to original buildings.

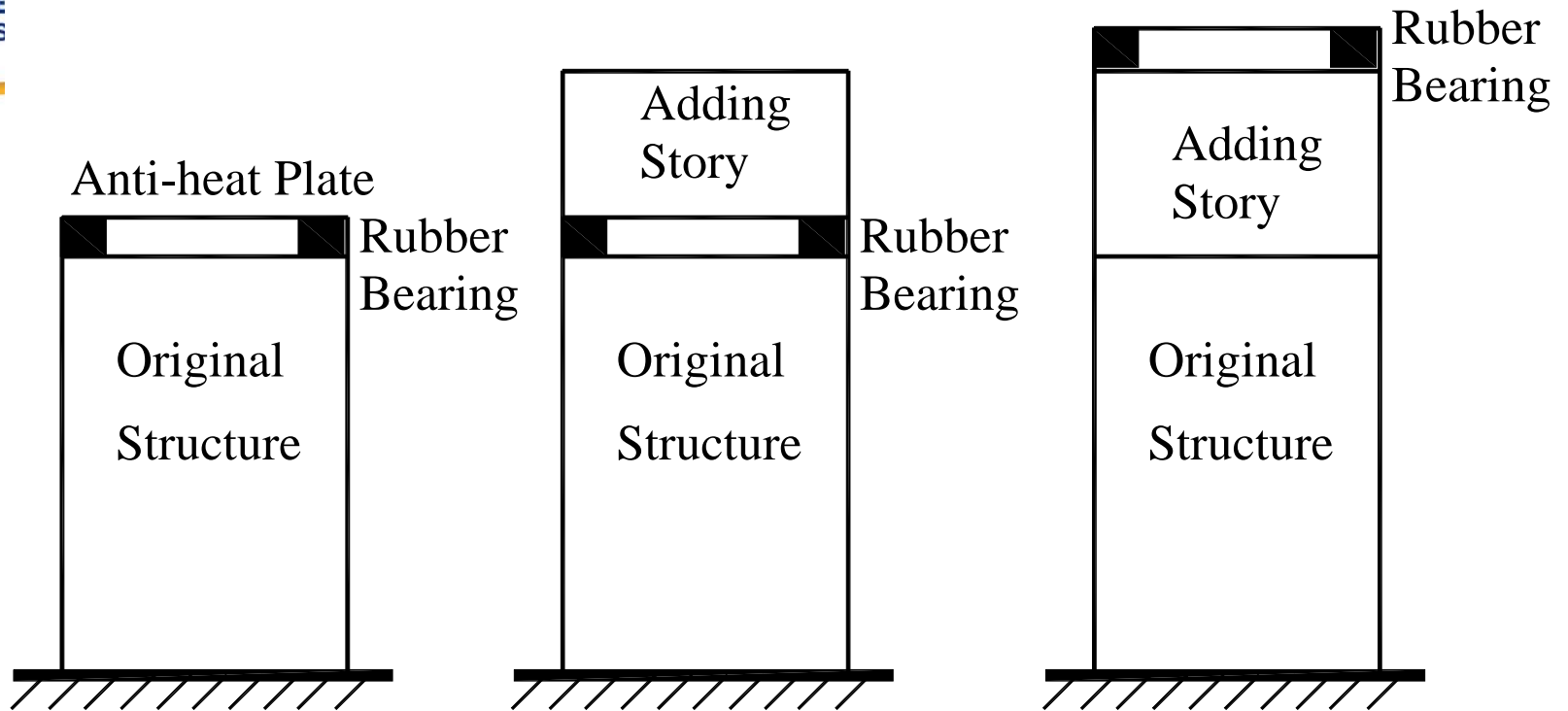

Concept illustration of inter-story isolation



Comparing of shaking table test on frame structure models with different inter-story isolation scheme

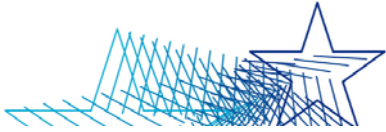

- The test results show that compared with common structures without this system, the earthquake responses of the structures with this system were reduced by 20%~40%.
- The calculation and design method has been developed to analyze and to design the inter-story isolation system.
- This method has been applied to more than twenty strengthening projects in China.

8. Study on Design Code

- National seismic design code (deformation checking criteria, elasto-plastic analysis methods,...).
- **Shanghai local codes:**
- Seismic design code (chief editor– Xilin Lu, Tongji University, **10 major revisions** to National code, 2003)
- Seismic evaluation and retrofitting code (chief editor– Xilin Lu, 2000)

9. Summary

EU-CHINA 14 -19 JUNE 2010

- The seismic energy dissipation and damage control of building structures were studied with applications as well as standards and design codes in recent years.
- The energy dissipation technologies will be more acceptable for easy construction, low cost and high performance.

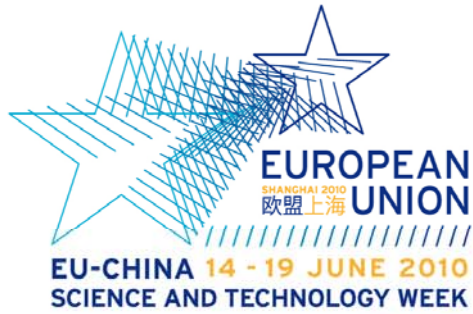

The end!

Thank you for your attention!