



JRC Information Day, April 11, 2008

Research for Sustainable Energy Development Croatia - a candidate country

Prof.dr.sc. Neven Duić

Head of Power Engineering and Energy Management Chair

- Croatia - a candidate country
 - Opportunities and barriers
- EU strategy for energy and environment
 - Security of supply
 - Reduction of GHG emissions
 - Regional development and employment opportunities
 - A crash application on Croatia
 - How to reduce negative impacts and increase win-win alternatives

- Croatia - where we are now?
 - 10% RES in primary energy supply in 2005, mainly hydro electricity and biomass heat
 - 34.7% RES-E including large hydro in 2005, 0.8% other than large hydro
 - Feed-in tariffs: 36% RES-E including large hydro planned for 2010, 5.8% other than large hydro
 - 0% biofuels in 2005, Obligation: 5.75% planned for 2010
 - RES-H: traditional biomass in 2005, investment support scheme in preparation

- Croatia - where we are now?
 - Cogeneration and district heating - developed but not highly efficient - feed in tariffs
 - Energy label for appliances
 - Energy label for buildings ...
 - Barriers to ESCO ...

- Croatia - where we have to follow EU?
 - 20% increase in energy efficiency
 - 20% reduction in greenhouse gas (GHG) emissions
 - 20% share of renewables in overall EU energy consumption by 2020
 - 10% biofuel component in vehicle fuel by 2020

- University of Zagreb
 - 60000 students
- Faculty of Mechanical Engineering and Naval Architecture (FSB-UZ)
 - 1600 students
 - 120 lecturers
- Energy concerned teaching & research (~50 rsrch)
 - Department of Energy, Power Engineering and Environment
 - Power Engineering and Energy Management Chair, Chair of Turbomachinery, Chair of Fluid Mechanics, Chair of Ecology and Water Treatment Technology (+ 2 laboratories)
 - Department of Thermodynamics, Thermal and Process Engineering
 - Chair of Technical Thermodynamics, Chair of Thermal and Process Engineering (+ 2 laboratories)



Power Engineering and Energy Management Chair

- 6 lecturers + 6 PhD students + 2 MSc students
- Research funding
 - 30% funding from Croatian:
 - Ministry of Science, Education and Sport;
 - Ministry of Economy, Labour and Entrepreneurship;
 - Environmental Protection and Energy Efficiency Fund of the Republic of Croatia;
 - Ministry of Environmental Protection, Physical Zoning and Construction
 - 30% funding from EC (LIFE, FP5, FP6, IEE)
 - 40% funding from industrial contracts (HEP, AVL, etc.)



Power Engineering and Energy Management Chair

- **Sustainable Energy Development**
 - Power Plants Technologies, Optimisation and Control
 - Cogeneration Technology and Optimisation
 - Energy Systems Optimisation
 - Energy Management and Energy Efficiency in Industry
 - Energy Economics, Policy and Planning
 - Capacity Building in Energy and Environment, Promotion of Energy Technologies
- **Control & System Dynamics**
- **Computational Fluid Dynamics**
 - Combustion modelling
 - gas and oil fired furnaces and combustion chambers
 - Radiation modelling

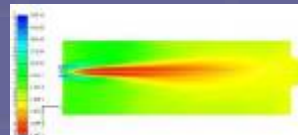

Power Engineering and Energy Management Chair

- Sustainable Energy Development – EC projects
 - LIFE**Cro**CHP Sustainable Development of Croatian CHP Sector (2002-2004)
<http://powerlab.fsb.hr/lifecrochp/>
 - multicriterial sustainability analysis of different CHP scenaria in Croatia
 - analysis comprised economic, environmental and social aspects of cogeneration and confirmed that cogeneration increases sustainability of Croatian development
 - The results of the project activities were recognized by officials from Energy and Mining Division of the Ministry of Economy, Labour and Entrepreneurship who are responsible for energy legislation and support measures for cogeneration have been imposed

Power Engineering and Energy Management Chair

■ Sustainable Energy Development

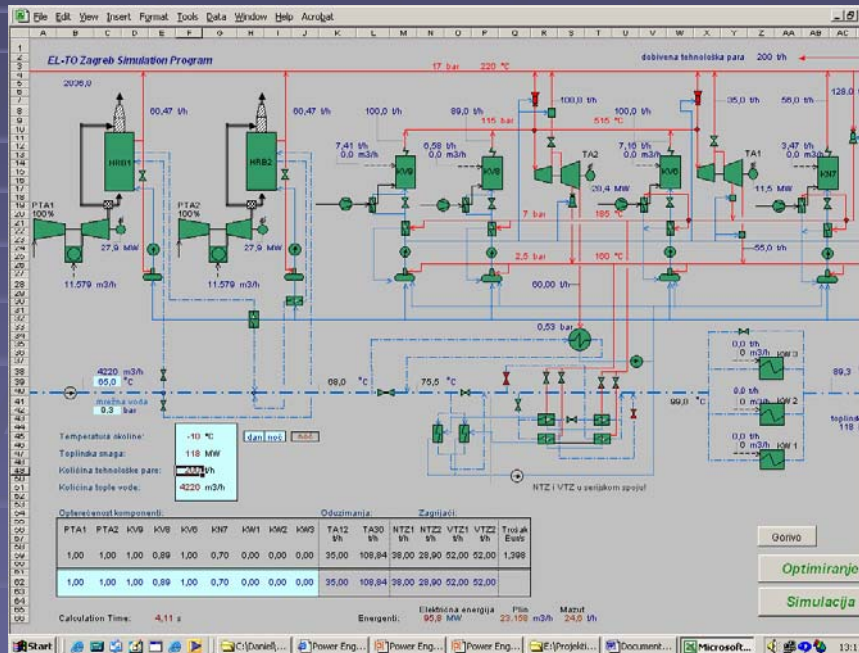

ACOM – optimisation of utility cogeneration plants

Power Engineering and Energy Management Chair

- Sustainable Energy Development – EC projects
 - ADEG: Advanced Decentralised Energy Generation Systems in Western Balkans (FP6-STREP-INCO, 2004-2007)
 - leading of two work packages
 - Mapping of RES and DEG potential
 - Database of RES companies in Croatia
 - Evaluation of technologies for use of renewable energy sources in decentralized energy generation
 - Investigation of the most promising configurations for the advanced utilisation of renewable energy
 - Standard modelling procedure for selection of DEG concept in Western Balkans
 - RES technology dissemination

ADEG Resources atlas

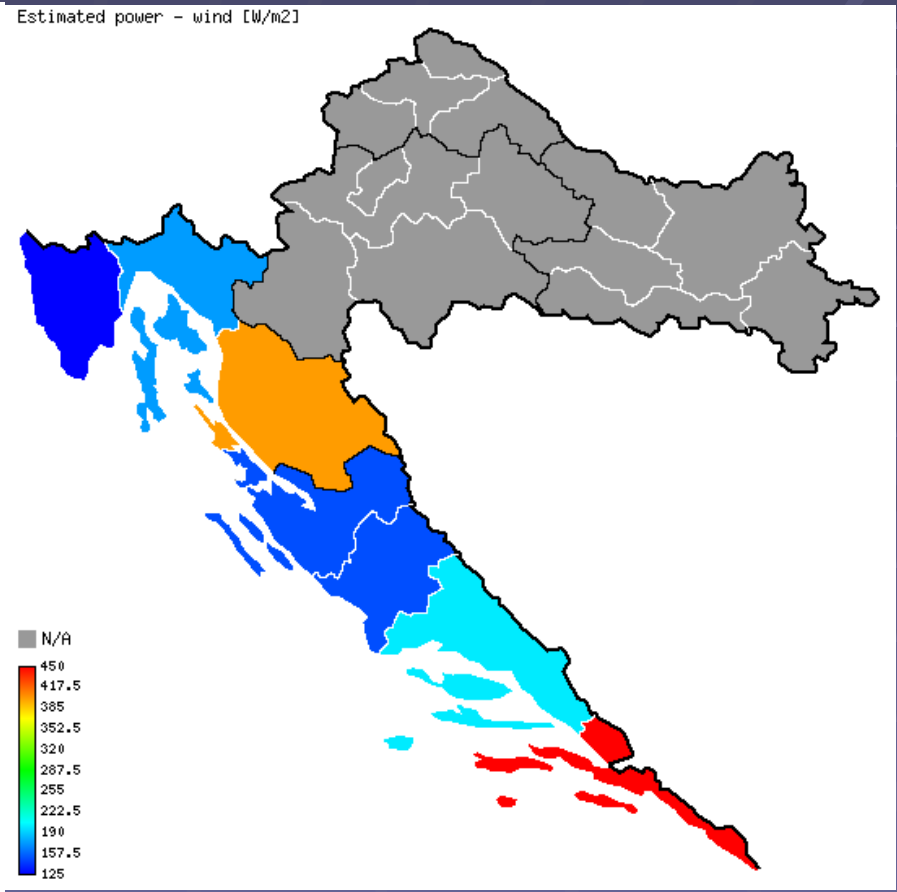
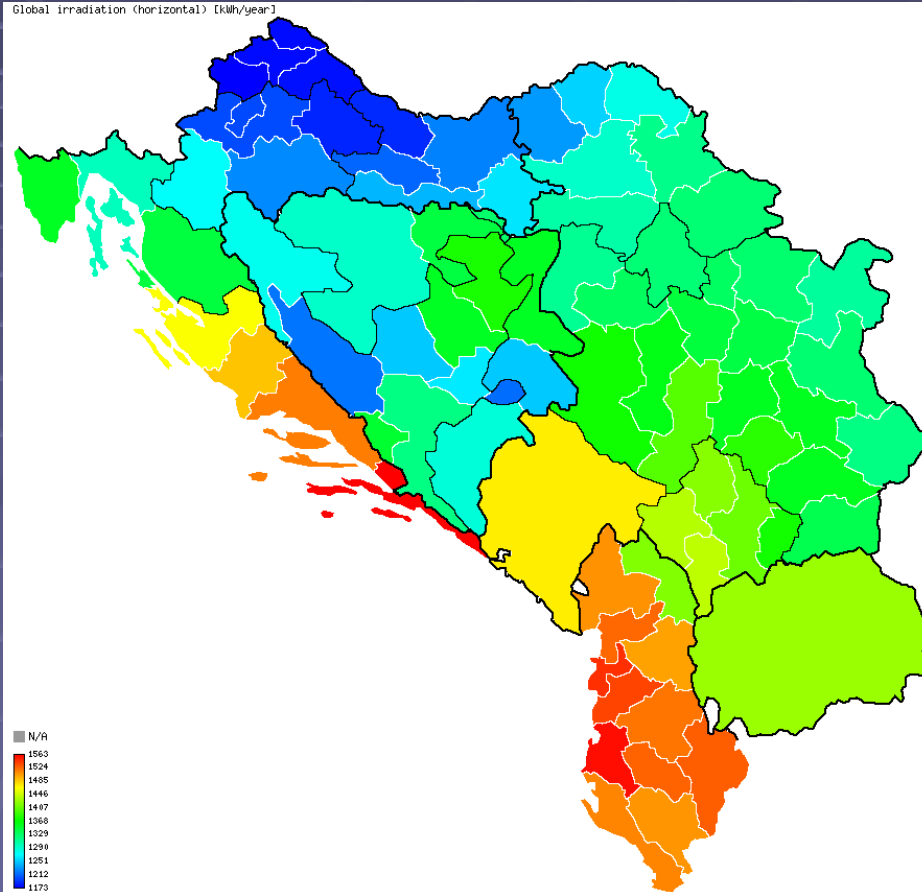

Solar

Wind

<http://powerlab.fsb.hr/adeq/>

RESOURCES

TECHNOLOGIES

COMMODITIES



Solar

Hydrogen Storage

Heat

Hydrogen

Cold

Electricity

Biofuels

Biogas

Water

Electrolysis

Fuel cell
Trigeneration

Reforming

Esterification
Fermentation

Gasification

Desalination

Wind

Wind turbines

Reversible hydro p.p.

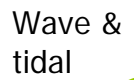

Wave & tidal

Sea

Hydro
Fresh water

Geothermal p.p.

Biomass p.p.

Geothermal

Biomass

Wastewater
treatment

Waste

Wastewater

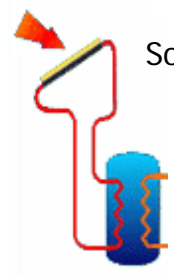

Solar panels

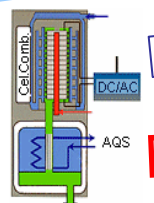

PV panels

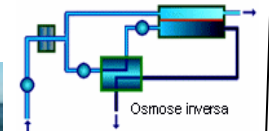
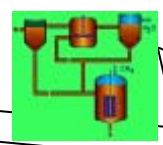
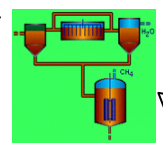
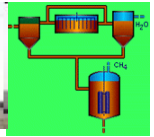
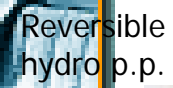

Osmose inversa

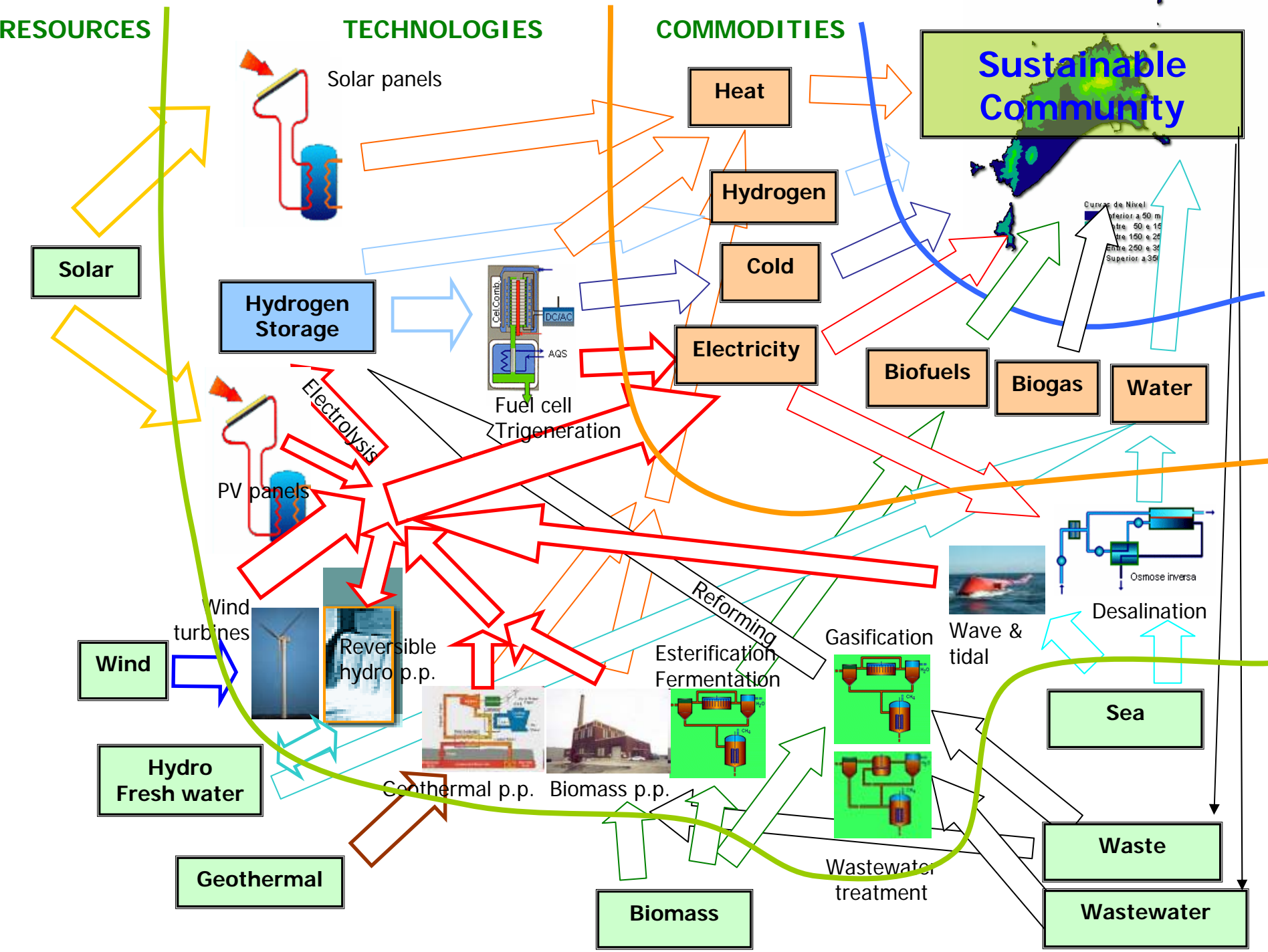

RenewIslands/ADEG METHODOLOGY

1. Mapping the **needs**
2. Mapping the **resources**
3. Devising **scenarios** with technologies that can use available resources to cover needs
4. **Modelling** the scenario

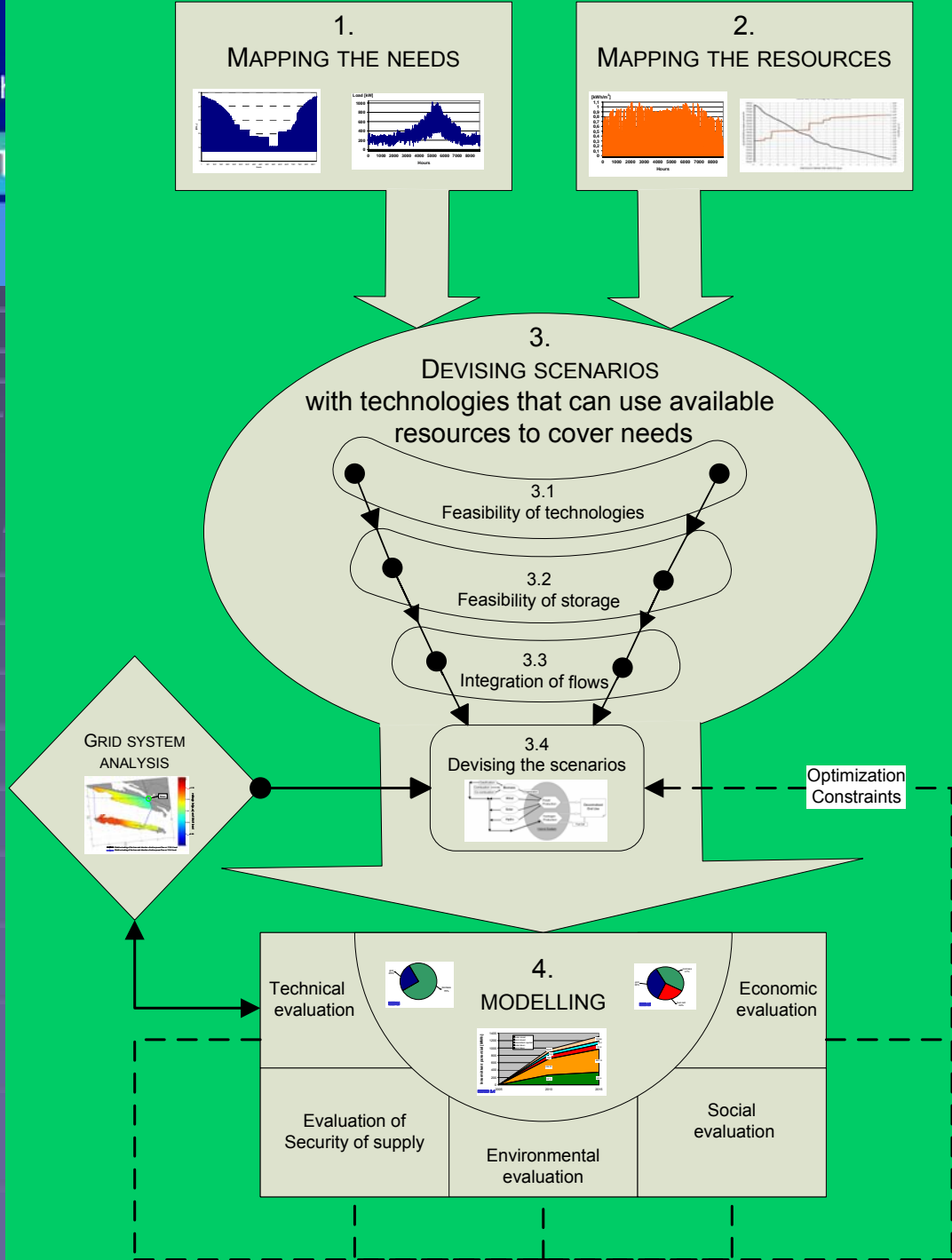

Power Engineering and Energy Management Chair

■ Sustainable Energy Development

H₂RES 2.7

<http://powerlab.fsb.hr/H2RES/>

Developed by:

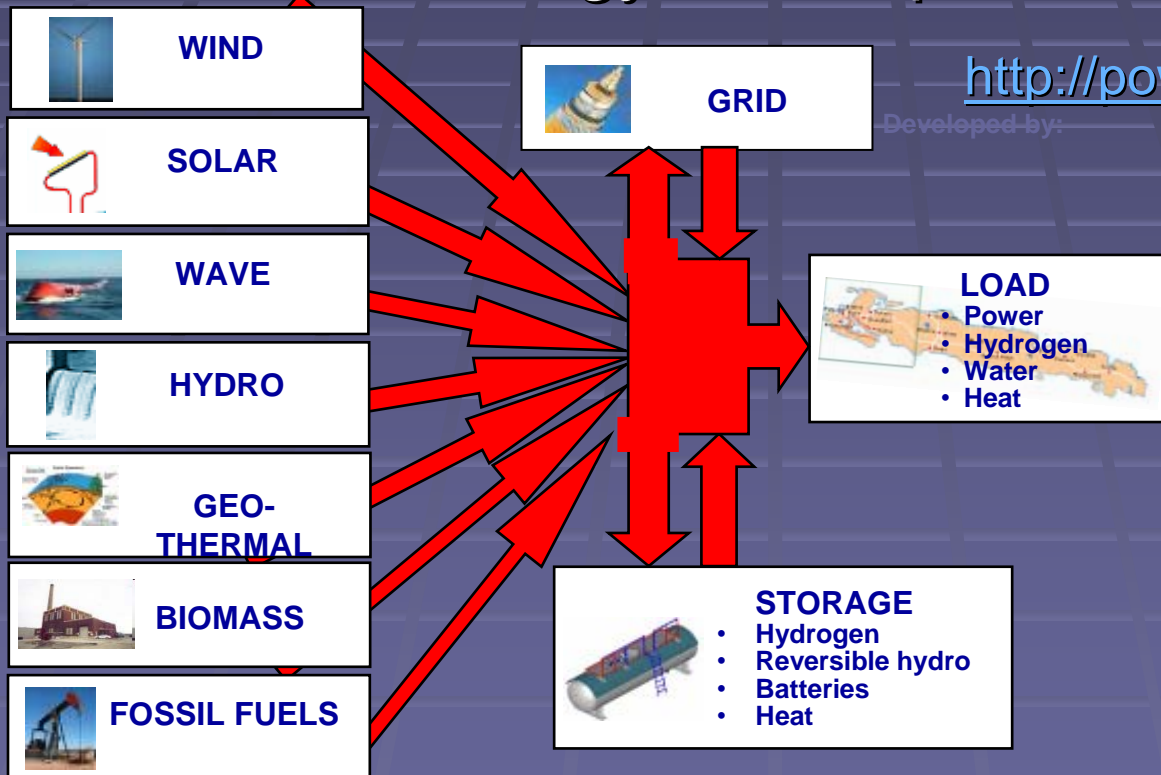

H₂RES – Energy planning tool

Developed together with IST

MLJET – Energy plan

- 3 km wide and 37 km long, 100,4 km² surface
- Highest peak (Veli Grad, 514 m)
- 1237 inhabitants (1991.)
- 1111 inhabitants (2001.)
- 52 km roads

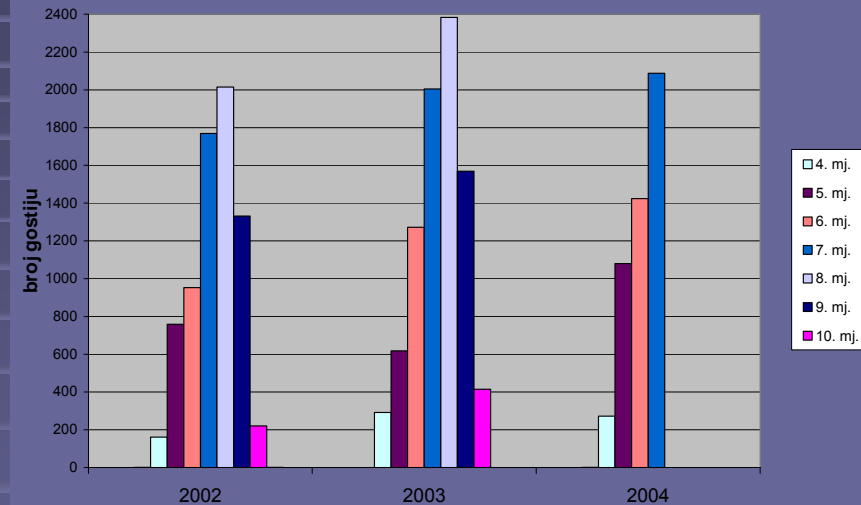

MLJET – Energy plan

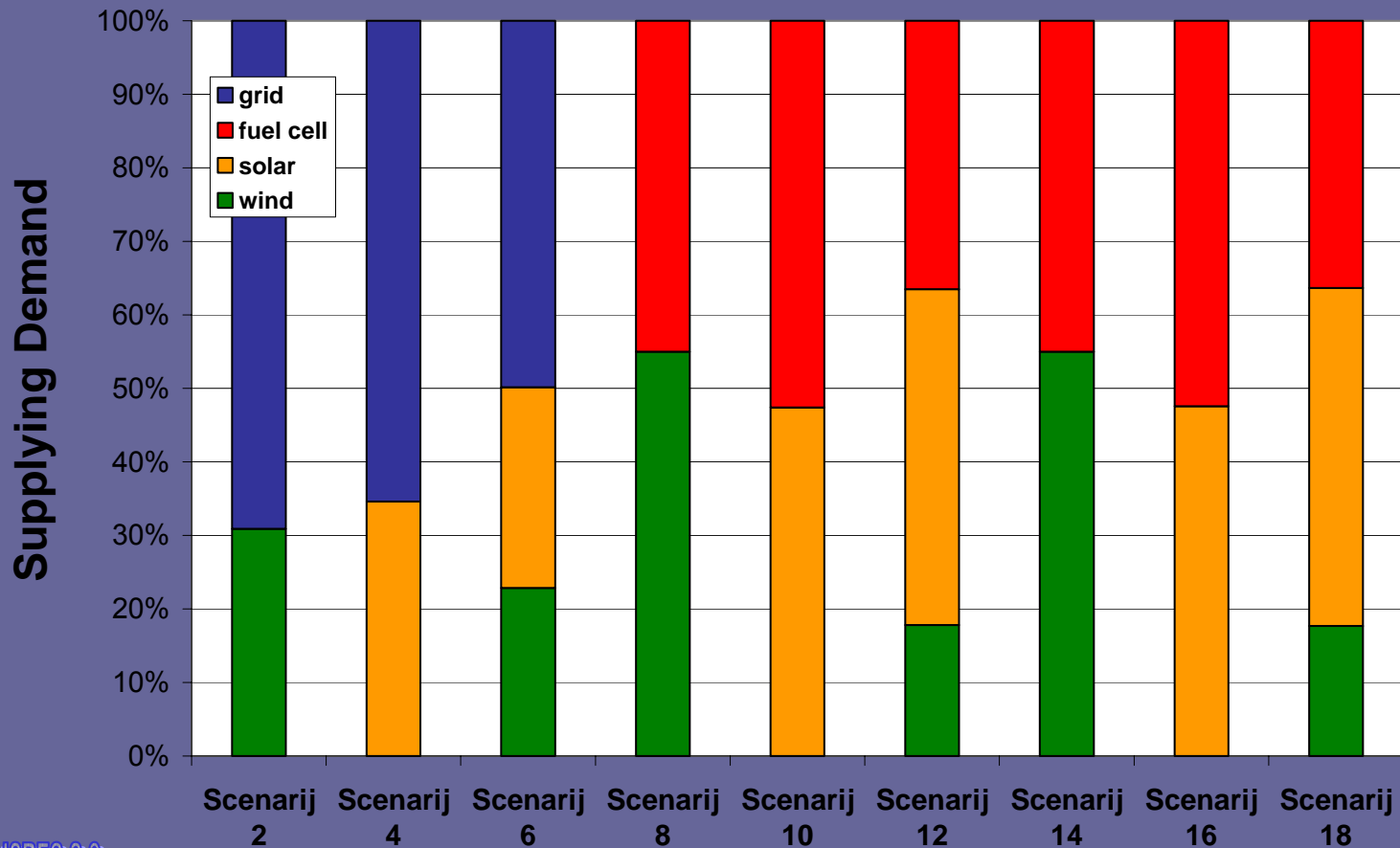

Power Engineering and Energy Management Chair

■ Sustainable Energy Development



**Dubrovnik Conference on Sustainable Development of
Energy, Water and Environment Systems**

2002 (INCO FP5), 2003, 2005, 2007

www.dubrovnik2007.fsb.hr

Power Engineering and Energy Management Chair

OTHER PROJECTS

- **WEB-ENV (FP6-SSA-INCO)**
 - Development of Environmental Guidelines for the Region of Western Balkans
- **WEB-MOB (FP6-SSA-INCO)**
 - Development of Mobility Guidelines for the Region of Western Balkans
- **GERONIMO (IEE)**
 - Getting Energy Reduction on Agendas in Industrial Manufacturing Operations
- **STORIES (IEE)**
 - Addressing regulations on STORAge technologies for increasing the penetration of Intermittent Energy Sources
- **SMART (IEE)**
 - Strategies to promote small scale hydro electricity production in Europe
- **Flick the Switch + BIOSIRE (IEE in negotiation)**



Power Engineering and Energy Management Chair

OTHER PROJECTS

- Preparation of bylaws in the area of renewable energy sources and cogeneration
- Legislation preparation for biofuels
- Renewable Energy Resources Project, GEF/IBRD Grant
- National Allocation Plan, CARDS
- Computer aided energy education: Introduction to Energy Management On-line
- Multicriterial optimisation of Energy Systems



Problems to solve in Croatia

- Socioeconomic research – how to create a society in which sustainable energy development is a win-win?
 - Regional development
 - Industrial R&D – energy clusters ...
 - Developers
- Energy planning – for sustainable development

Opportunities

- A rural (semi-industrialised?) society in transition into tourist economy
 - Great opportunity to sort things out properly but also a danger to solve it only formally
 - It is imperative to succeed in order to achieve economic sustainability of tourism

Research funding

- Difficult to find current Croatian priorities in Energy calls ...
 - If EU wants to achieve goals, it will have to find different ways for countries in different phase
 - New member states and candidate countries need more socioeconomic research dedicated to their specific problems



Thank you for your attention

Neven.Duic@fsb.hr