

Ex-post Evaluation of IST Research in FP6

Follow-up to Panel Recommendations

*CLORA Workshop
December 3rd 2008*

**Frank Cunningham
Evaluation and Monitoring Unit
Information Society and Media DG
European Commission**



Follow-up of the Evaluation Results

Capturing the needs for information

- **The ex-post evaluation of ICT was designed in such a way that its results (findings and recommendations) were useful**
- **It was properly timed and the evaluation findings were disseminated to stakeholders**
- **Recommendations will be taken into account in the revisions of the FP ICT RTD work-programme**



Follow-up of the Evaluation Results Timeliness

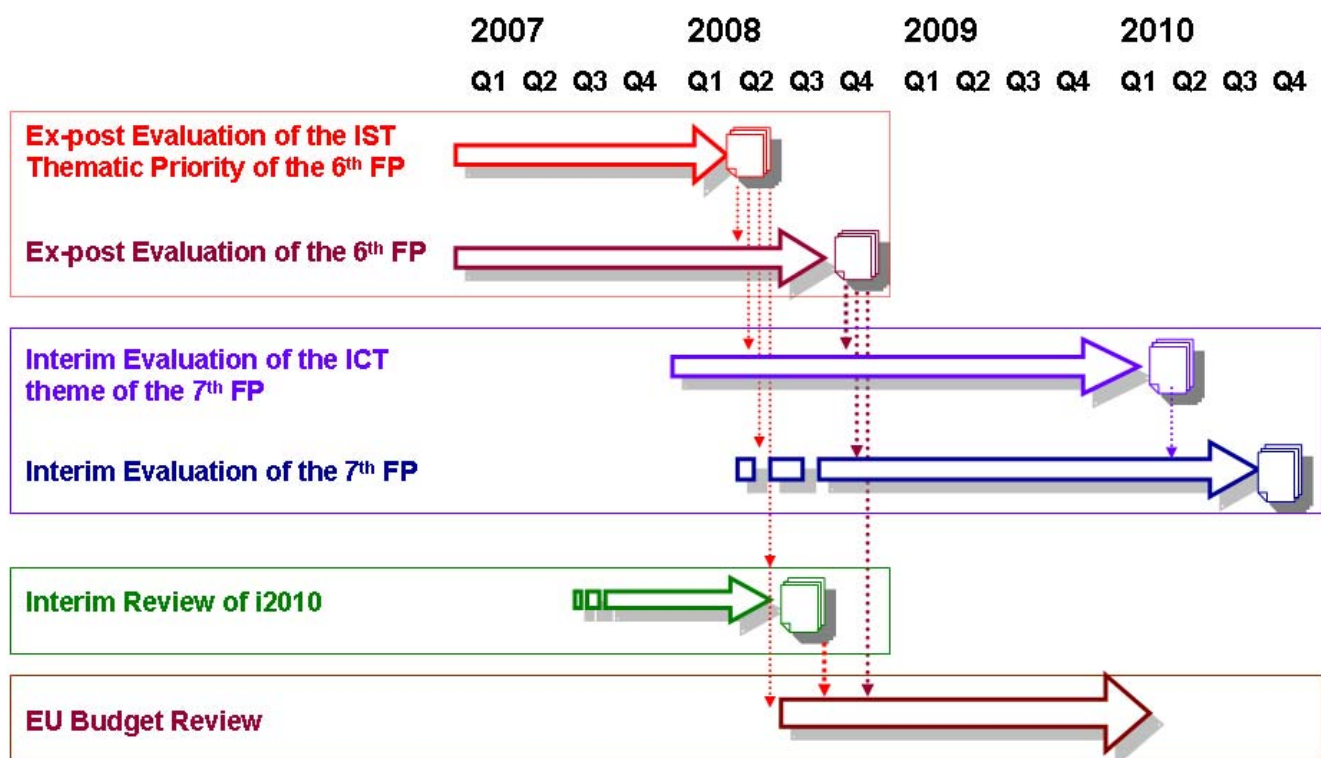

Follow-up of the Evaluation Results

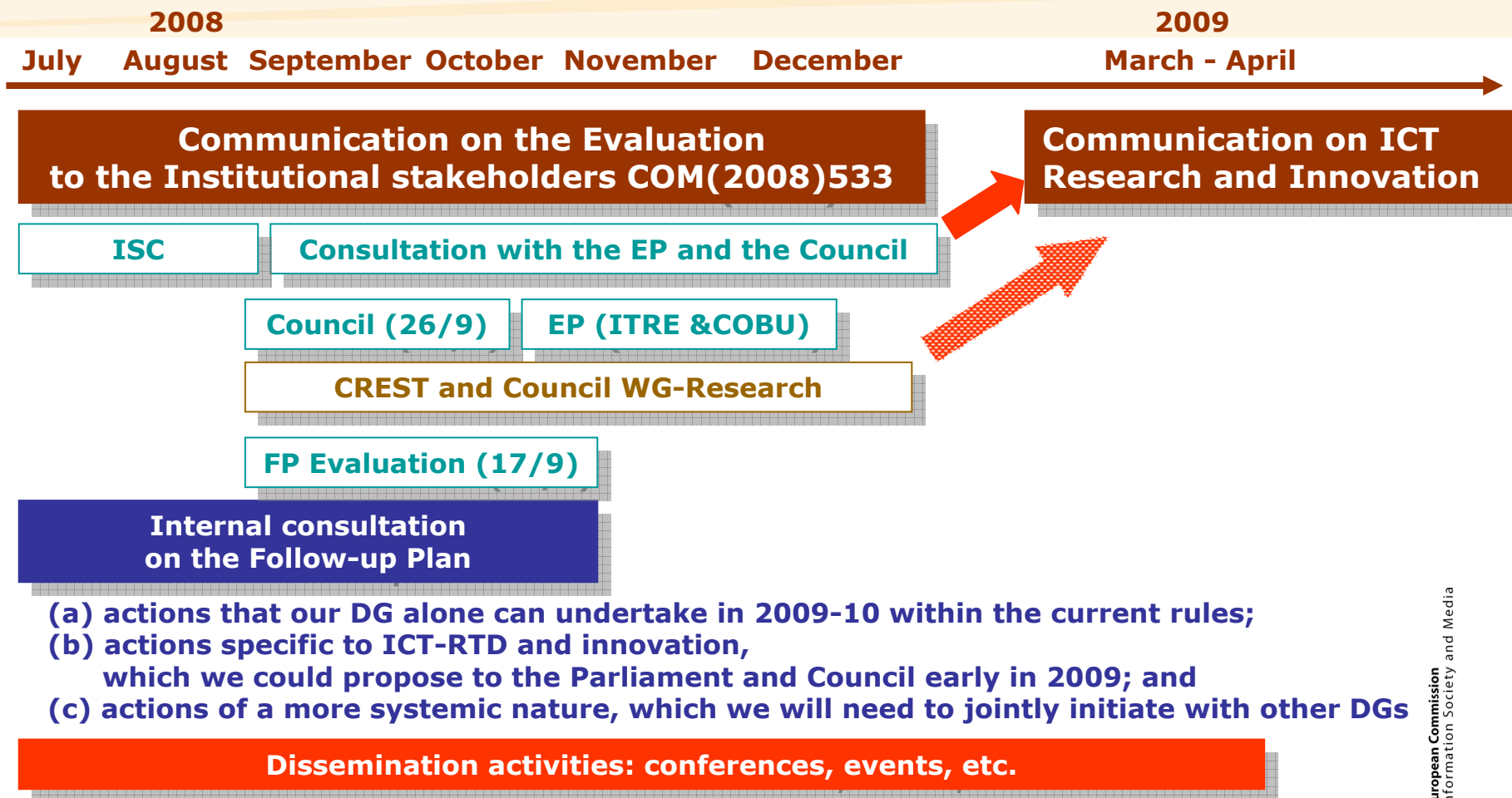

Follow-up of the Evaluation Results

Communication on ICT and Innovation

- **Objectives:**
 - to propose a policy approach for ICT research, development and innovation in the EU
 - to facilitate the emergence of new markets for innovative ICT-based products and services
- **Part of the Commission's response to recommendations from the ex-post evaluation of IST RTD in FP6 (Aho Panel)**
- **Expected publication in late February next year**
- **Online public consultation from Sept to Nov '08**



Actions that our DG alone can undertake in 2009-10 within the current rules

- **Increasing Global reach and reputation of participation in FP ICT RTD**
- **Simplifying Management/Reducing Red-Tape**
- **Expansion of eInfrastructures approach to more application and user-oriented in sectors beyond scientific research**
- **Better Access to Venture Capital**



Actions specific to ICT-RTD and innovation requiring co-operation with EP, Council

- **Encourage public authorities to procure the development of innovative goods and services**
- **Develop a single market for business angels and VCs**
- **More effective use of the EIF to 'pull-through' innovations from the FP**

Actions of a more systemic nature, which we will need to jointly initiate with other DGs

- **Strengthen Networking Opportunities**
 - Continue to consolidate public-private partnerships of a more permanent nature from FP7 such as the JTI's
- **Create and Access European and Global Markets**
 - A more strategic approach to, and use of standardisation at the European Level
 - Further development of interconnection of large regional and national infrastructures



Annex

Background information

about

the Ex-post evaluation of IST Research in FP6



i2010 Strategy

- Comprehensive and holistic approach:
 - Umbrella initiative for EU Information Society and Media policies (regulation, research and deployment)

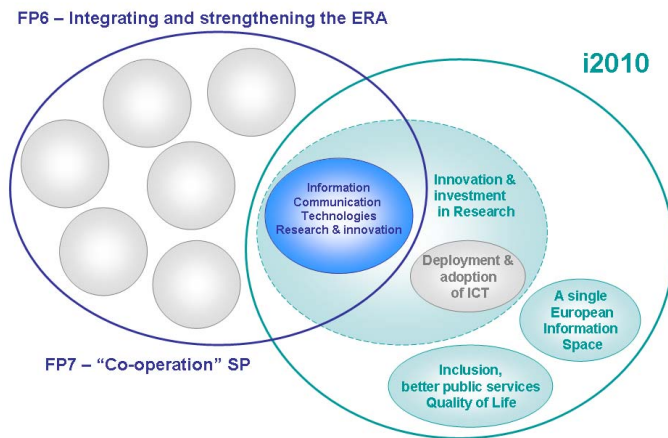

Three priorities:

- Completing the Single European Information Space
- Strengthening innovation and investment in research
- Achieving an Inclusive European Information society



EU Framework Programmes evolution

Complementary instruments and wider mobilisation of resources

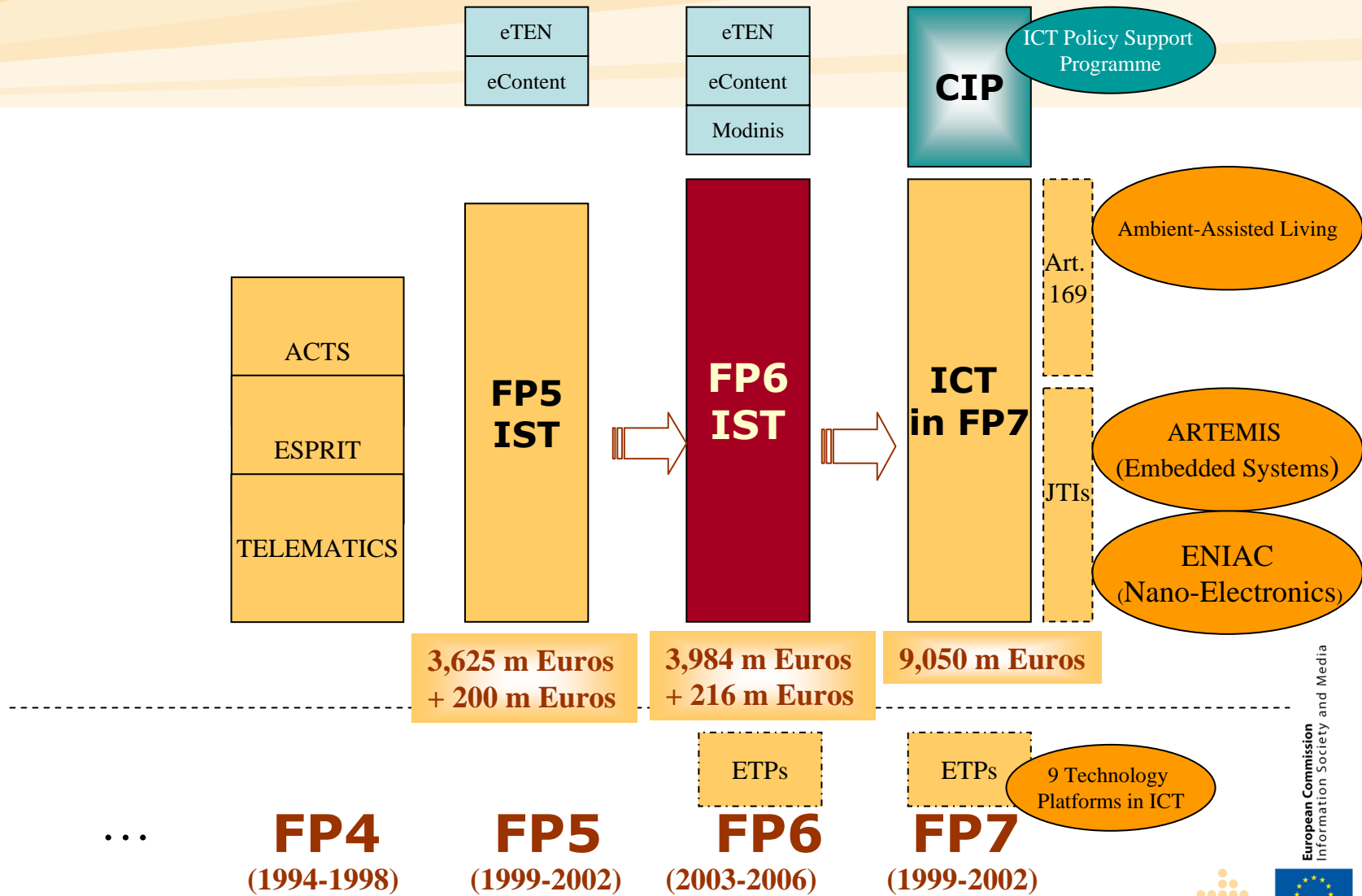

European Commission
Information Society and Media



Requirements for Accountability and Sound Financial Management

Financial Regulation - Art 27 and 60:

The Commission (AO) is responsible to implement the budget in accordance with the principle of Sound Financial Management, and therefore perform an ex-post evaluation of the research activities.

Not later than 2010, the Commission shall carry out, with the assistance of external experts, an evidence-based interim evaluation of this Framework Programme and its specific programmes building upon the ex-post evaluation of the Sixth Framework Programme...

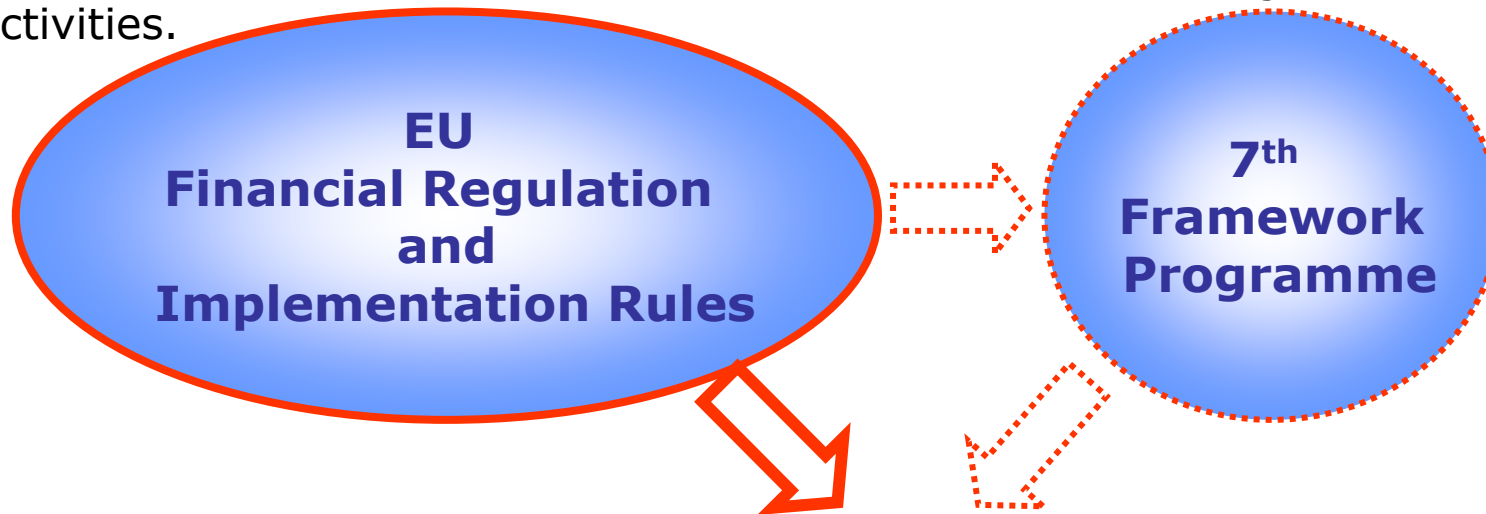

Ex-post Evaluation of IST research in FP6



A Panel of external high-level experts

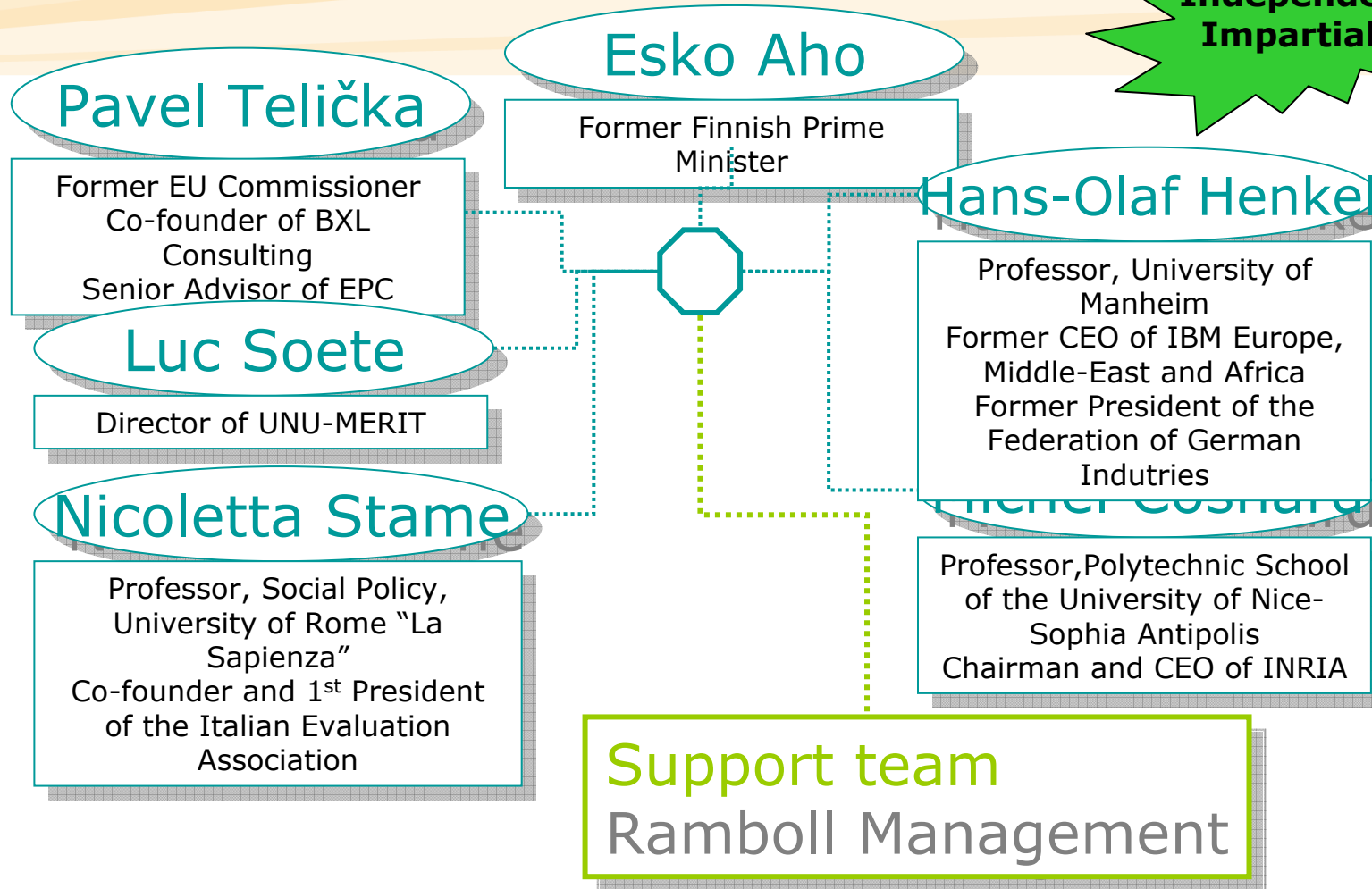

Evaluation Process



Building evidence base

Studies based on network analyses
Study of the IST intervention logic
Impact Analysis Observatory
Studies on Indicators
Collection of data related to indicators (patents and publications)
Study of impacts on Growth and Jobs
Study of SMEs
IST research portfolio analysis

**Acceptability
Credibility**

**Utility
Value Added**

Phase A

Compilation of the available evidence and initial analysis
Preparation of the Self-Assessment

Phase B

Consultation with stakeholder groups
Synthesis of the evidence
Preparation of an annotated outline of the report

Phase C

Collection of additional evidence
Interviews and with key ICT players
Preparation of a draft report

Phase D

Interaction with institutional stakeholders
Finalization of the report



The Evaluation report is published

http://ec.europa.eu/dgs/information_society/evaluation/rtd/fp6_ist_expost/index_en.htm

Information Society Research and Innovation: Delivering results with sustained impact

Evaluation of the effectiveness of Information Society Research in the 6th Framework Programme 2003-2006

MEMO/08/430
Brussels, 24 June 2008

"Aho Report" on EU High-Tech Research: A Wake-up Call for Innovation in Europe, says Commissioner Reding

Europe has started doing better in high-tech research to do, particularly to capitalise on the... independent expert report, chaired by Aho, that analysed the effectiveness of the EU's 4th Framework Programme. Although Europe has considerably improved its European Commission has considerably improved its (FP04-2003) and Nano-Euro... a gear to bridge the... (FP08-2004)

The EU has invested... and 2006, companies... the Commission... the Commission... with...

Information Society and Media Directorate-General

Ex-post Evaluation of the ICT theme of the 6th FP for RTD

Background and Legal Basis

Both the increasing importance of the changes in the policy content and the objectives of and the proposed level of investment in the EU's RTD activities result to the need to further improve and strengthen the evaluation function in order to best meet the public requirements for increased transparency, accountability and cost-effectiveness.

The Commission is therefore bound, through the Financial Regulation (Articles 60 and 27) and its Implementing Rules, to perform an ex-post evaluation of the 6th FP research activities in line with the principle for Sound Financial Management.

As a consequence of this obligation, the legal base of the 7th Framework Programme for Research, Technological development and Demonstration (RTD) explicitly mandates that "Not later than 2010, the Commission shall carry out, with the assistance of external experts, an evidence-based interim evaluation of this Framework Programme and its specific programmes building upon the ex-post evaluation of the Sixth Framework Programme." and clarifies that this "... independent ex-post programme evaluation would be undertaken 2 years after the end of FP6."

Key information

- Terms of reference
- Panel of Independent experts
- Evaluation report
- Web-based workspace



Key findings and recommendations (1)

The European ICT research investment has been well managed and has been effective in reaching its goals, but improvements can be made in:

- ❖ **the flexibility and simplification of the funding mechanism, by**
 - **Developing a more trust-based approach towards participants at all stages;**
 - **Adopting a number of changes at the operational level for example requesting shorter proposals, exploring new evaluation processes (more widely distributed seed funding), optimising reporting, etc.**
- ❖ **Encouraging more of the best researchers from outside of Europe to participate with the aim of increasing the global reach of the programme in areas where Europe can take the lead.**



Key findings and recommendations (2)

The exploitation of the created knowledge and skills depends on a broad portfolio of policies and measures which affect the innovation "eco-system".

Some recommendations

- Reintroducing mechanisms to facilitate new and high-growth companies to meet venture capital investors;
- Promoting stronger interactions between users, researchers and business - notably in regional innovation systems.
- Supporting new initiatives to allow public authorities to procure the development of innovative goods and services.
- Promoting interoperability and development of standards where there is a well-documented need for coherent innovative services and European leadership.
- Facilitating the development of lead markets for innovative ICT products and services
- Strengthening collaboration and mobilising public-private partnerships, as in the Joint Technology Initiatives.

Relevance
Strategic



Making the best possible use of the evaluation findings

