



EUROPEAN COMMISSION
DIRECTORATE-GENERAL ENERGY AND TRANSPORT

Luxembourg,
TREN I/1 ABS/bk I/1(2008)D/401664

INVITATION TO TENDER N°. TREN/I1/96-2008

(open procedure)

Dear Sir/Madam,

1. The European Commission invites tenders for a service contract regarding the following project:
Framework contract for customised electrical and electronical services

This invitation to tender follows the publication of:

- the contract notice in OJEU 2008/S 121-160498
2. If you are interested in this contract, you must submit a tender in **triplicate**, in one of the official languages of the European Union.

Tenders must be:

(a) either sent by registered mail or by private courier

The tender must be sent by registered mail or by private courier, dispatched not later than **27/08/2008**(the postmark or the receipt issued by the courier service serving as proof of the dispatch) to the following address:

European Commission
Directorate-Energy and Transport
Direction I – Nuclear Safeguards
Complexe Euroforum
For the attention of Ms A Adams-Webel/Mr Boella EUFO 3484
1, rue Henry M. Schnadt
Zone d'activités Cloche d'Or
L-2530 Luxembourg

(b) or delivered by hand

Tenders must be delivered by hand at the **Central Mail of the European Commission** by **27/08/2008 not later than 4 p.m. (Brussels time)**, at the following address:

European Commission
Directorate-Energy and Transport
Direction I – Nuclear Safeguards
Complexe Euroforum II- main entrance
For the attention of Ms A Adams-Webel/Mr Boella EUFO 3484
1, rue Henry M. Schnadt
Zone d'activités Cloche d'Or
L-2530 Luxembourg

In this case, a receipt must be obtained as proof of submission, signed and dated by the official in the Commission's central mail department who took delivery. The department is open from 08.00 to 16.00 Monday to Friday. It is closed on Saturdays, Sundays and Commission holidays.

3. Tenders must be placed inside two sealed envelopes, one inside the other. **The inner envelope should be marked:**

<p>Call for tenders No. TREN/I1/96-2008 <u>not to be opened by the internal mail department</u> EUFO – Archives</p>

If self-adhesive envelopes are used, they must be sealed with adhesive tape and the sender must sign across this tape.

The non-compliance with these formal conditions will entail the rejection of the bids at the opening session.

4. Tenders will be opened on **05/09/2008** at 10:00 EUFO II **2392**
1, rue Henry M. Schnadt
Zone d'activités Cloche d'Or
L-2530 Luxembourg

This opening session will be public. Each tenderer may be represented by not more than one person. At the end of the opening session, the Chairman of the opening committee will indicate the name of the tenderers and the decision concerning the admissibility of each offer received. The prices mentioned in the bids will not be communicated.

5. The specification, listing all the documents that must be produced in order to tender, including supporting evidence of economic, financial, technical and professional capacity and the draft contract are attached.
6. Tenders must be signed by the tenderer or his duly authorised representative and perfectly legible so that there can be no doubt as to words and figures.
7. Validity period of the tender: six months as from the final date for submission of tenders mentioned under point 2 above.
8. Submission of a tender implies acceptance of all the terms and conditions set out in this invitation to tender, in the specification, in the draft contract and, where applicable, waiver of

the tenderer's own general or specific terms and conditions. The terms and conditions are binding on the tenderer to whom the contract is awarded during the performance of the contract.

9. Contacts between the awarding authority and tenderers are prohibited throughout the procedure except in exceptional circumstances and under the following conditions only:

Before the closing date for submission of tenders

- At the request of the tenderer, the awarding authority may provide additional information solely for the purpose of clarifying the nature of the contract.

Requests for additional information must be sent in writing not later than six calendar days before the closing date for submission of tenders to the following address:

Ms A Adams-Webel/Mr Boella EUFO 3484
1, rue Henry M. Schnadt
Zone d'activités Cloche d'Or
L-2530 Luxembourg
Fax (+ 352) 430136059
e-mail: TREN-II-CFT@ec.europa.eu

- The Commission may, on its own initiative, inform interested parties of any error, inaccuracy, omission or any other material shortcoming in the text of the tender documents.

Further information will be sent simultaneously to all tenderers who have requested the specification in writing, where this is appropriate. Tenderers who have downloaded the documents from the Directorate-General Energy and transport website (DG TREN) are invited to consult this site regularly until the deadline for submission.

After the opening of tenders

If a tender requires clarification, or if there is a need to correct material errors which have occurred in the drafting of the tender, the Commission may take the initiative and contact the tenderer(s). Such contact shall not lead to the conditions of the tender being altered in any way.

10. This invitation to tender is in no way binding on the Commission. A commitment will come about only when a contract with the successful tenderer has been signed.

Until a contract is signed, the awarding authority may decide not to award a contract or to cancel the tendering procedure, without the candidates or tenderers being entitled to claim any compensation. Where appropriate, the decision will be substantiated and brought to the attention of the tenderers.

11. Tenderers will be informed of whether their tenders have been accepted or rejected.

12. The follow-up of your response to the invitation to tender will require the recording and further processing of personal data (i.e. name, address, CV, etc.). This data will be processed in accordance with the requirements of Regulation (CE) 45/2001 on the protection of individuals with regard to the processing of personal data by Community institutions and bodies and on the free movement of such data. Unless if otherwise stated, replies to questions and personal data requested are necessary for the purpose of assessing your tender (according to the specifications of the invitation to tender) and will only be processed within DG TREN

as data controller, for this purpose. You may, upon request, have your personal data sent to you and rectify any inaccurate or incomplete particulars. Should you have any queries concerning the processing of your personal data, please address them to the entity acting as data controller within DG TREN. As regards the processing of your personal data, you have the right to bring the matter before the European Data Protection Supervisor at any time.

13. You are informed that for the purposes of safeguarding the financial interest of the Communities, your personal data may be transferred to internal audit services, to the European Court of Auditors, to the Financial Irregularities Panel and/or to the European Anti-Fraud Office (OLAF).

Data of economic operators which are in one of the situations referred to in Articles 93, 94, 96(1)(b) and 96(2)(a) of the Financial Regulation may be included in a central database and communicated to the designated persons of the Commission, other institutions, agencies, authorities and bodies mentioned in Article 95(1) and (2) of the Financial Regulation. This refers as well to the persons with powers of representation, decision making or control over the said economic operators. Any party entered into the database has the right to be informed of the data concerning it, up on request to the accounting officer of the Commission.

Yours faithfully,

Christian Cleutinx
Director

TENDER SPECIFICATIONS
ATTACHED TO THE INVITATION TO TENDER

**Invitation to tender N° TREN /I1/96-2008 concerning
the framework contract for customised electrical and electronical services**

TABLE OF CONTENTS

I	SPECIFICATIONS
I.1	INTRODUCTION
I.2	PURPOSE OF THE CONTRACT
I.2.1.	DEVELOPMENT, DESIGN AND COUNSELLING
I.2.2.	PRODUCTION AND SUPPLY OF ELECTRONIC UNITS
I.2.3.	SERVICE, MAINTENANCE AND REPAIR OF ELECTRICAL AND ELECTRONIC UNITS
I.2.4.	MATERIALS AND TOOLING USED FOR SERVICES
I.3.	QUOTATIONS TO PRODUCE
I.4	EXECUTION OF THE WORK ORDER
I.5	THE COSTS OF PACKAGING AND DELIVERY
I.6	ACCEPTANCE OF PERFORMED SERVICES
I.7	DURATION OF THE TASKS
I.8	PLACE OF PERFORMANCE AND DELIVERY
I.9	ESTIMATE OF THE AMOUNT OF WORK INVOLVED
II	TERMS OF CONTRACT
II.1	TERMS OF PAYMENT
II.2	FINANCIAL GUARANTEES
II.3	SUBCONTRACTING
II.4	LEGAL FORM TO BE TAKEN BY THE GROUPING OF SERVICE PROVIDERS TO WHOM THE CONTRACT IS AWARDED (IF APPLICABLE)
III	FORM AND CONTENT OF THE TENDER
III.1	GENERAL
III.2	STRUCTURE OF THE TENDER
III.2.1	<i>FIRST SECTION: ADMINISTRATIVE PROPOSAL</i>
III.2.2	<i>SECOND SECTION: TECHNICAL PROPOSAL</i>
III.2.3	<i>THIRD SECTION: FINANCIAL PROPOSAL</i>
IV	ASSESSMENT AND AWARD OF THE CONTRACT
IV.1	EXCLUSION CRITERIA - EXCLUSION OF TENDERERS
IV.1.1	<i>EXCLUSION CRITERIA (ART. 93 OF FINANCIAL REGULATION)</i>
IV.1.2	<i>OTHER CASES OF EXCLUSION</i>
IV.1.3	<i>EVIDENCE TO BE PROVIDED BY THE TENDERERS</i>
IV.1.4	<i>ADMINISTRATIVE AND FINANCIAL PENALTIES</i>
IV.2	SELECTION CRITERIA – SELECTION OF TENDERERS
IV.2.1	<i>ECONOMICAL AND FINANCIAL CAPACITY – REFERENCES REQUIRED</i>
IV.2.2	<i>TECHNICAL AND PROFESSIONAL CAPACITY – REFERENCES REQUIRED</i>
IV.3	EVALUATION OF TENDERS - AWARD CRITERIA
IV.4	INFORMATION FOR TENDERERS
V	ANNEXES

I. SPECIFICATIONS

I.1. Introduction

To discharge of its responsibilities under Chapter VII of the EURATOM Treaty, the European Commission maintains measurement systems in nuclear installations across the European Union. For the design, production, supply and repair of components of these systems, electrical and electronical services are needed.

I.2. Purpose of the contract

This is a framework contract with one contractor for electrical and electronical services, which will include the design, development, counselling, maintenance, service/repair of the electrical and electronic equipment associated with these activities as well as the tooling and materials required for the task.

Any action which would be carried out under this framework contract will be triggered by the Commission as defined in this Specification by signed order (Annex III of the draft contract), in which the technical specification and details will be defined.

The tenderers will be required to carry out the following category of work:

I.2.1. Development, design and counselling

Tenderers should design electronic circuitry including design of printed circuit boards with appropriate component layout. They will also be required to provide advice and counselling at the design stage of work to be carried out by them.

I.2.2. Production and supply of electronic units

The quantity of electronic products will be required in single or small series (1-10 units). Examples of the electronic products are listed below:

- ◆ Signal processing electronics;
- ◆ Electronic modules for video, neutron and gamma measurement applications;
- ◆ Special printed circuit boards;
- ◆ Electronic components for the manufacture of electronic modules;
- ◆ Cables, adapters, housings and connectors as well as other ancillary equipment associated with the production of electronic modules;
- ◆ Low and high voltage stabilised power supply units and etc.

Pay attention that the nature of production will not be limited to the above-mentioned.

I.2.3. Service, maintenance and repair of electrical and electronic units

Service and maintenance and repair of electrical and electronic equipment will consist of the types of equipment mentioned in the section 1.2.2 as well as various types of video and measurement equipment.

I.2.4. Materials and tooling used for services

- a) Provide suitable materials for carrying out the work specified in the above points as well as materials for operation and maintenance of the equipment supplied.
- b) Tenderer will have to supply, at short notice, small items of material and tooling to facilitate the service/repair of electrical equipment such as that associated with section I.2.2. to I.2.3. above.

- c) Special Tooling: In cases where special tooling must be fabricated in order to carry out a work order the following rules will apply:
- Any special tooling to be financed by the Commission will be subject to prior approval.
 - Prior to approval the Commission will require the submission of a dimensioned drawing stating the materials used and number of hours needed to complete the production.
 - The Commission reserves the right to keep any such tooling at its headquarters and it will in all cases remain the property of the European Commission.
 - In cases where it is more convenient for tooling to be stored at the tenderer workshops the Commission insists that it be used exclusively for work requested by it.
 - On termination of the contract all special tooling financed under that contract will be turned over to the Commission.

I.3. Quotations to produce

Quotations are based on written request for the services described in section I.2.1, I.2.2, I.2.3. and I.2.4. The tenderer will provide a quotation based on the price list mentioned in the tender, together with sufficient technical description. Furthermore a date of delivery and warranty, as mention on draft framework contract on Article I.9.2.b, for that action should be proposed.

The contractor will submit a quotation to the Commission at latest 15 calendar days after receiving of the written request (Annex II of the draft framework contract).

The quotations will be sent in writing to an appointed member of Commission staff.

- a) The contractor may be required to send an appointed person to the Commission to discuss technical details and to estimate the cost of particular projects prior to commencement of work. All related transport and other costs for this will be borne by the tendering company. From previous experience this can be expected to be at least four times per year.
- b) The quotations will be required to show:
 - the number of hours of each work category to be used as mention on section I.2.1, I.2.2, and I.2.3
 - the cost of materials as mention on section I.2.4
 - the total cost to carry out the work, including number of hours of each work category and cost of materials.
- c) The Commission shall approve or reject these quotations. They will be evaluated on an individual basis and a written acceptance will be sent to the contractor (Annex III of the draft frame work contract).

I.4. Execution of the work order

The time limit for completion and delivery of ordered goods/services will be 10 working days from the date of receiving the purchase order, if the ordered work does not exceed 40 hours. Longer delivery times can be agreed (e.g. if particular materials are required or the volume of work is larger). In cases where the production of an engineering drawing is necessary prior to commencement, the delivery time will automatically be prolonged by 7 working days.

I.5. The costs of packaging and delivery

The packaging and delivery of the ordered goods or services will be borne by the tenderer.

I.6. Acceptance of performed services

The Commission shall have 20 calendar days to approve or reject the goods/service by signature of the Record of Technical Acceptance (Annex IV of the draft framework contract).

After the technical acceptance the contractor can send his invoice and will be paid as described in Article I.4.1 of the draft contract.

I.7. Duration of the tasks

The contract is for a period of 12 months and may be extended twice by 12 months each.

I.8. Place of performance and delivery

The tasks will be performed on the Contractor's premises. However, meetings between the contractor and the Commission may be held on Commission premises in Luxembourg (Section I.3a).

The tenderer will deliver the goods to Luxembourg to the following address:

European Commission
Directorate-Energy and Transport
Direction I – Nuclear Safeguards
Complexe Euroforum II
For the attention of Ms A Adams-Webel/Mr Boella EUFO 3484
1, rue Henry M. Schnadt
Zone d'activités Cloche d'Or
L-2530 Luxembourg

I.9. Estimate of the amount of work involved

The indicative maximum amount is EUR 150.000 (up to 3 years).

II. TERMS OF CONTRACT

In drawing up his offer, the tenderer should bear in mind the provisions of the draft contract attached to this invitation to tender (Annex 7). Any limitation, amendment or denial of the terms of contract will lead to automatic exclusion from the procurement procedure.

The Commission may, before the contract is signed, either abandon the procurement procedure or cancel the award procedure without the tenderers being entitled to claim any compensation.

II.1. Terms of payment

Payments shall be made in accordance with the provisions specified in Annex 7, the draft service contract.

II.2. Financial guarantees

Guarantee on pre-financing

The guarantee on pre-financing is not applicable.

II.3. Subcontracting

If the tenderer intends to subcontract part of the service, he shall indicate in his offer which part will be subcontracted and to what extent (% of the total contract value).

Tenderers must inform the subcontractor(s) that Article II.17 of the contract (Annex 7) will be applied to them. Once the contract has been signed, Article II.13 of the above-mentioned contract shall govern the subcontracting.

II.4. Legal form to be taken by the grouping of service providers to whom the contract is awarded (if applicable)

Groupings, irrespective of their legal form, may submit bids. Tenderers may, after forming a grouping, submit a joint bid on condition that it complies with the rules of competition. Such groupings (or consortium) must specify the company or person heading the project and must also submit a copy of the document authorising this company or person to submit a bid. If awarded, the contract will be signed by the company or the person heading the project, who will be, vis à vis the Commission, the only contracting party responsible for the performance of this contract. Tenders from a consortium of firms or groups of service providers, contractors or suppliers must specify the role, qualifications and experience of each member of the consortium or group. Each member must provide all the necessary documents for assessing the bid as a whole with regard to the exclusion criteria, selection criteria (all of them) and award criteria.

III. FORM AND CONTENT OF THE TENDER

III.1. General

Tenders must be written in **one of the official languages** of the European Union.

Tenders must be clear and concise, with continuous page numbering, and assembled in a coherent fashion (e.g. bound or stapled, etc...).

Since tenderers will be judged on the content of their written bids, they must make it clear that they are able to meet the requirements of the specifications.

III.2. Structure of the tender

All tenders must include three sections i.e. an administrative, a technical and a financial proposal.

III.2.1. Section One: administrative proposal

This section must provide the following information, set out in the standard identification forms attached to these tender specifications (Annexes 3, 4 and 5):

- Tenderers' identification (Annex 3)
 - All tenderers must provide proof of **registration**, as prescribed in their country of establishment, on one of the **professional or trade registers** or provide a declaration or certificate.
 - If the tenderer is a natural person, he/she must provide a copy of the identity card/passport or driving licence and proof that he/she is covered by a social security scheme as a self-employed person.

Each tenderer (including subcontractor(s) or any member of a consortium or grouping) must complete and sign the identification forms in Annex 3 and also provide above-mentioned documents. However, the subcontractor(s) shall not be required to fill in or provide those documents when the services represent less than 20% of the contract.

- Financial identification (Annex 4)

The **bank identification form** must be filled in and signed by an authorised representative of the tenderer and his/her banker. A standard form is attached in Annex

4 and a specific form for each Member State is available at the following Internet address:

http://ec.europa.eu/budget/execution/ftiers_en.htm

In the case of a grouping, this form must only be provided by the person heading the project.

- Legal entities (Annex 5)

The legal entity form in Annex 5 must be filled in and should be accompanied by a number of supporting documents, available on the Web site:

http://ec.europa.eu/budget/execution/legal_entities_en.htm

In the case of a grouping, this form must only be provided by the person heading the project.

The Commission reserves the right, however, to request additional evidence in relation to the bid submitted for evaluation or verification purposes within a time-limit stipulated in its request.

III.2.2. Section Two: Technical proposal

This section is of great importance in the assessment of the bids, the award of the contract and the future execution of any resulting contract.

The technical proposal must provide all the information needed for the purpose of awarding the contract.

III.2.3. Section Three: Financial proposal

All tenders must contain a financial proposal. The tenderer's attention is drawn to the following points:

- Prices must be quoted (**euros/hour**) for each category of service:
 - 1- development, design and counselling,
 - 2- production and supply of electronic units,
 - 3- service, maintenance and repair of electrical and electronic units
- Prices and materials for tooling cannot be known at the time of the tender but will have to be provided for each quotation for specific work
- Prices must be quoted in **euros**, including the countries which are not in the euro-area. As far as the tenderers of those countries are concerned, they cannot change the amount of the bid because of the evolution of the exchange rate. The tenderers choose the exchange rate and assume all risks or opportunities relating to the rate fluctuation.
- Prices must be fixed amounts and include all expenses, such as travel expenses and daily allowances.
- **Prices should be quoted free of all duties, taxes and other charges, i.e. also free of VAT**, as the Communities are exempt from such charges in the EU under Articles 3 and 4 of the Protocol on the Privileges and Immunities of the European Communities of 8 April 1965 (OJ L 152 of 13 July 1967). Exemption is granted to the Commission by the governments of the Member States, either through refunds upon presentation of documentary evidence or by

direct exemption. For those countries where national legislation provides an exemption by means of a reimbursement, the amount of VAT is to be shown separately. In case of doubt about the applicable VAT system, it is the tenderer's responsibility to contact his or her national authorities to clarify the way in which the European Community is exempt from VAT;

- **Prices shall be** fixed and not subject to revision during the performance of the contract;

Bids involving more than one service provider (consortium) must specify the amounts indicated above for each provider.

IV. ASSESSMENT AND AWARD OF THE CONTRACT

The assessment will be based on each tenderer's bid.

All the information will be assessed in the light of the criteria set out in these specifications. The procedure for the award of the contract, which will concern only admissible bids, will be carried out in three successive stages.

The aim of each of these stages is:

- 1) to check on the basis of the exclusion criteria, whether tenderers can take part in the tendering procedure;
- 2) to check on the basis of the selection criteria, the technical and professional capacity and economic and financial capacity of each tenderer;
- 3) to assess on the basis of the award criteria each bid which has passed the exclusion and selection stages.

IV.1. Exclusion criteria (exclusion of tenderers)

IV.1.1. Exclusion criteria (Article 93 Financial Regulation¹)

1. To be eligible for participating in this contract award procedure, tenderers must not be in any of the following exclusion grounds:

- (a) they are bankrupt or being wound up, are having their affairs administered by the courts, have entered into an arrangement with creditors, have suspended business activities, are the subject of proceedings concerning those matters, or are in any analogous situation arising from a similar procedure provided for in national legislation or regulations;
- (b) they have been convicted of an offence concerning their professional conduct by a judgement which has the force of res judicata;
- (c) they have been guilty of grave professional misconduct proven by any means which the contracting authority can justify;
- (d) they have not fulfilled obligations relating to the payment of social security contributions or the payment of taxes in accordance with the legal provisions of the country in which they are established or with those of the country of the contracting authority or those of the country where the contract is to be performed;

¹ Council Regulation (EC, Euratom) No 1605/2002 of 25 June 2002 on the Financial Regulation applicable to the general budget of the European Communities (OJ L 248 of 16.9.2002)

- (e) they have been the subject of a judgement which has the force of *res judicata* for fraud, corruption, involvement in a criminal organisation or any other illegal activity detrimental to the Communities' financial interests;
 - (f) they are currently subject to an administrative penalty referred to in Article 96(1) of the Financial Regulation² for being guilty of misrepresentation in supplying the information required by the contracting authority as a condition of participation in a contract procurement procedure or by the authorising officer as a condition of participation in a grant award procedure, for failing to supply this information or for having been declared to be in serious breach of their obligations under contracts or grants covered by the Community budget.
2. The cases referred to in point IV.1.1. e) above shall be the following:
- a) cases of fraud as referred to in Article 1 of the Convention on the protection of the European Communities' financial interests established by the Council Act of 26 July 1995 (OJ/C 316 of 27.11.1995, p. 48);
 - b) cases of corruption as referred to in Article 3 of the Convention on the fight against corruption involving officials of the European Communities or officials of Member States of the European Union, established by the Council Act of 26 May 1997 (OJ/C 195 of 25.6.1997, p. 1);
 - c) cases of involvement in a criminal organisation, as defined in Article 2(1) of Joint Action 98/733/JHA of the Council (OJ/L 315 of 29.12.1998, p. 1);
 - d) cases of money laundering as defined in Article 1 of Council Directive 91/308/EEC (OJ/L 166 of 28.6.1991, p.77).

IV.1.2. Other cases of exclusion (Article 94 Financial Regulation)

Contracts will not be awarded to tenderers who, during the procurement procedure:

- a) **are subject to a conflict of interest;**

Tenderers must declare:

- that they do not have any conflict of interest in connection with the contract; a conflict of interest could arise in particular as a result of economic interests, political or national affinities, family or emotional ties, or any other relevant connection or shared interest;
- that they will inform the contracting authority, without delay, of any situation constituting a conflict of interest or which could give rise to a conflict of interest;
- that they have not made and will not make any offer of any type whatsoever from which an advantage can be derived under the contract;
- that they have not granted and will not grant, have not sought and will not seek, have not attempted and will not attempt to obtain, and have not accepted and will not accept, any advantage, financial or in kind, to or from any party whatsoever, constituting an illegal practice or involving corruption, either directly or indirectly, as an incentive or reward relating to the award of the contract.

The Commission reserves the right to check the above information.

² Council Regulation (EC, Euratom) n° 1605/2002 of 25 June 2002 on the Financial regulation applicable to the general budget of the European Communities, OJ L 248 of 16 September 2002, p. 1, amended by Council Regulation (EC, Euratom) n° 1995/2006 of 13 December 2006, OJ L 390 of 30 December 2006, p.1.

- b) **are guilty of misrepresentation** in supplying the information required by the contracting authority as a condition of participation in the contract procedure or fail to supply this information.
- c) find themselves in one of the **situations of exclusion**, referred to in paragraph IV.1.1. above for this procurement procedure.

IV.1.3. Evidence to be provided by the tenderers

1. When submitting their bids, each tenderer (including subcontractor(s) or any member of a consortium or grouping) shall provide a declaration on their honour, duly signed and dated, stating that they are not in one of the situations mentioned above (cf. IV.1.1 and VI.1.2). For that purpose, they must complete and sign the form attached in Annex 6. Where the tenderer is a legal entity, they shall, whenever requested by the Commission, provide information on the ownership or on the management, control and power of representation of the legal entity.
2. The tenderer to whom the contract is to be awarded shall provide, within 15 calendar days after notification of the results of the procurement procedure and in any case before the signature of the contract, the following evidence, confirming the declaration referred to above:

The Commission shall accept, as satisfactory evidence that the tenderer is not in one of the situations described in point IV.1.1 (a), (b) or (e) above, a recent extract from the judicial record or, failing that, an equivalent document recently issued by a judicial or administrative authority in the country of origin or provenance showing that those requirements are satisfied.

The Commission accepts, as satisfactory evidence that the tenderer is not in the situation described in point IV.1.1 (d) above, a recent certificate issued by the competent authority of the State concerned.

Where no such document or certificate is issued in the country concerned, it may be replaced by a sworn or, failing that, a solemn statement made by the interested party before a judicial or administrative authority, a notary or a qualified professional body in his country of origin or provenance.

3. Depending on the national legislation of the country in which the candidate or tenderer is established, the documents referred to in paragraph 1 and 2 above shall relate to legal and/or natural persons including, if applicable with regard to points b) and e), company directors or any person with powers of representation, decision-making or control in relation to the tenderer.
4. When the subcontracted part is above 20% of the contract value, the subcontractor(s) must also provide the above-mentioned declaration on honour. In case of doubt on this declaration on the honour, the contracting authority may also request the evidence referred to in paragraphs 2 and 3 above.
5. The Commission reserves the right to request any other document relating to the proposed tender for evaluation and verification purpose, within a delay determined in its request.

Remark:

The tenderers will be waived of the obligation to submit the documentary evidence above mentioned if such evidence has already been submitted for the purposes of another procurement procedure launched by Directorate General for Energy and Transport and provided that the documents are not more than one year old starting from their issuing date and that they are still valid. In such a case, the tenderer shall declare on his honour that the documentary evidence has already been provided in a previous procurement procedure, specifying the reference of the call for tender for which the documents have been provided, and confirm that no changes in his situation have occurred.

IV.1.4. Administrative and financial penalties

Without prejudice to the application of penalties laid down in the contract, candidates or tenderers and contractors who have been found guilty of misrepresentation in supplying the information required by the contracting authority as a condition of participation in the procurement procedure or have failed to supply this information or have been declared to be in serious breach of their obligations under contracts covered by the Community budget may be subject to administrative or financial penalties, in accordance with Article 96 of the Financial Regulation and Articles 134b and 133a of the Implementing Rules.³

IV.2. SELECTION CRITERIA (SELECTION OF TENDERERS)

To be eligible, the tenderers must have the economic and financial capacity as well as the technical and professional capacity to perform the tasks required in this call for tender.

IV.2.1. Economic and financial capacity – References required

Tenderers must provide proof of their financial and economic capacity by means of the following documents: the balance sheets or extracts from balance sheets for the last three financial years, and a statement of overall turnover and turnover relating to the relevant services for the last three financial years.

This rule applies to all service providers, regardless of the percentage of tasks they intend to execute, once they have chosen to submit a tender. However, if the tender includes subcontractors whose tasks represent less than 20% of the contract, those subcontractors are not obliged to provide evidence of their economic and financial capacity.

IV.2.2. Technical and professional capacity – References required

Tenderers should submit proof to show that:

- they have experience in the area of engineering concerned and to submit as evidence of this a list of activities for the previous 2 years;
- they employ an electronics engineer with more than 3 years professional experience;
- they employ personnel with experience in signal processing and video technology;
- they have sufficient staff to meet the delivery times laid out in section I.4.

For all the points mentioned above supporting documentation will have to be provided.

³ Commission Regulation (EC, Euratom) n° 2342/2002 of 23 December 2002 laying down detailed rules for the implementation of Council Regulation (EC, Euratom) No 1605/2002 on the Financial Regulation applicable to the general budget of the European Communities, OJ L 357 of 31 December 2002, p. 1, last amended by Commission Regulation (EC, Euratom) n° 478/2007 of 23 April 2007, OJ L 111 of 28 April 2007, p.1.

IV.3. EVALUATION OF TENDERS – AWARD CRITERIA

The contract will be awarded according to the criteria given below, on the basis of the economically most advantageous tender.

Only bids that have reached a total score of a minimum of 70% and a minimum score of 60 % for each criterion will be taken into consideration for awarding the contract.

The result of this evaluation will be based on the technical documentation supplied with tender plus the technical merit of the example technical specifications (Annex Nr.1 and Nr.2).

The contract will be awarded to the tender who offers the best ratio quality/price (Q/P).

a) Evaluation of the Quality (Q): Technical evaluation criteria in their order of importance as weighted by percentage

N°	Award Criteria	Weighting
1	Understanding (Annex Nr.1 and Nr.2):: <ul style="list-style-type: none">- Quotation's conformity to requirements of specifications- Understanding of importance of material proposed- Suggestions made: for example alternatives or counselling to the electrical specifications	40%
2	Methodology for carrying out the work (Annex Nr.1 and Nr.2): <ul style="list-style-type: none">- Details shown on example quotations- Quality of proposed methodology- Professionalism of approach	30%
3	Project Management for the realisation of the quality (Annex Nr.1 and 2): <ul style="list-style-type: none">- Quality and clarity of tender- Quality and clarity of the example quotations- Hourly rate expressed as required- Warranty offered- Delivery time proposed- Quality control	30%
Maximal number of points		100

The result of the technical evaluation will be a quality coefficient Q for the tender.

b) Evaluation of the price P

Solely for the purpose of evaluating the tenders and in order to allow a comparison of prices, examples are given below. The examples concern some work as it could be typically requested under this framework contract. The tenderers are expected to work out and submit with the tender the specific quotations for these example tasks.

The total price used for the evaluation will be the sum of the quotations for the two example tasks (Annex Nr.1 and Nr.2). The quotations are expected to contain in detail the hourly rates and the number of hours and the price of all materials required for the work. The total price

will be calculated as the sum of the prices for the example quotations i.e. (hourly rates x No of hours) + price of materials.

The result of this evaluation will be a price coefficient P for the tender.

IV.4. INFORMATION FOR TENDERERS

The Commission will inform tenderers of decisions reached concerning the award of the contract, including the grounds for any decision not to award a contract or to recommence the procedure.

If a written request is received, the Commission will inform all rejected tenderers of the reasons for their rejection and all tenderers submitting an admissible tender of the characteristics and relative advantages of the selected tender and the name of the successful tenderer.

However, certain information may be withheld where its release would impede law enforcement or otherwise be contrary to the public interest, or would prejudice the legitimate commercial interests of economic operators, public or private, or might prejudice fair competition between them.

V. ANNEXES

1. Typical specification Example Nr.1
2. Typical specification Example Nr.2
3. Identification of the Tenderer
4. Financial Identification
5. Legal Entity Form
6. Declaration by the Tenderer (relating to the exclusion criteria)
7. Draft framework service contract

ANNEX 1

TYPICAL SPECIFICATIONS EXAMPLE NR.1:

Description: high voltage combiner box

The equipment to be designed/built has the following features:

- Inputs = 2 externally supplied high voltages (2000volt, 5mA maximum)
- Output = 1 OR'd high voltage, using suitable blocking diodes (like BY203-20S)
- Enclosure: $\pm 100 \times 100 \times 25$ mm sealed diecast box (painted) with 3 x SHV bulkhead connectors
- Inputs labelled "HV1", "HV2"
- Output labelled "HVred"

Schematic diagram:

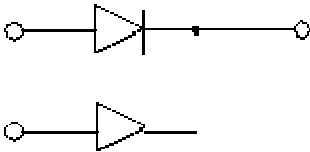

Sample picture:



ANNEX 2

TYPICAL SPECIFICATIONS EXAMPLE NR.2:

Description: redundant dual HV/LV power supply, in 19” rack case 2U

The equipment to be designed/built has the following features:

- Input = nominal 230V_{ac} mains power ($\pm 10V$)
- Output A,B = adjustable HV power supply: 12V_{dc}/0 – 2000 V_{dc} (positive), 1mA max, ripple < 5mV @ full load condition, connector = SHV type (e.g. Brandenburg model 4479-106 12V/2KV module or similar). Adjustment potentiometers on front panel.
- Output C,D = regulated power supply: 12V_{dc}(positive), 1.5A max, ripple < 5mV @ full load condition, load regulation < 0.5%, line regulation < 0.5%, connector = BNC type (e.g. industry standard open frame linear PSU)
- Output E,F = fixed power supply : 5V_{dc}(positive), 1.5A max (via suitable step-down voltage regulator e.g. 7805 series) connector = BNC type
- Output G = redundant 0-2000V_{dc} output (via suitable blocking diodes e.g. BY203-20S, from outputs A,B to a single SHV type connector)
- Output H = redundant 12V_{dc} output (via suitable blocking diodes e.g. 1N5404, from outputs C,D to a single BNC type connector)

Note: output C,D (12V) **OR** output E,F (5V) will be used, **never both together**

Further requirements:

- IEC mains connector (internal fuse) and flying cord (2.5 – 3m long) with moulded connectors (IEC female + universal European plug – earthed)
- Main switch: DPDT switch with visual “on” indication
- Two 3½ LCD digital voltmeters for high voltage outputs (connected to monitoring point on HV module, select between voltage and current by toggle or rotary switch). DVM characters minimal 12mm high. DVM’s have their own independent PSU (typically 5 –15V_{dc}(positive), upon model)
- Separate toggle switch to power the 12V_{dc} PSU’s + LED indicator “12V_{dc} on” (on front panel)
- Externally accessible fuses (1.5A, F) on both 12Vdc outputs C, D
- Externally accessible fuses (1.5A, F) on both 5Vdc outputs E,F
- Enclosure: 19” aluminium rack case, 2U high, with passive ventilation
- Output connectors labelled (e.g. HVp, HVs, HVred, 12Vp, 12Vs, 12Vred, 5Vp, 5Vs – where “p”, “s” and “red” indicate “primary”, “secondary” and “redundant”)
- IEC, BNC and SHV connectors plus fuse holders on rear panel
- Mains switch on front panel
- Construction and wiring according to applicable standards

Schematic diagram (simplified):

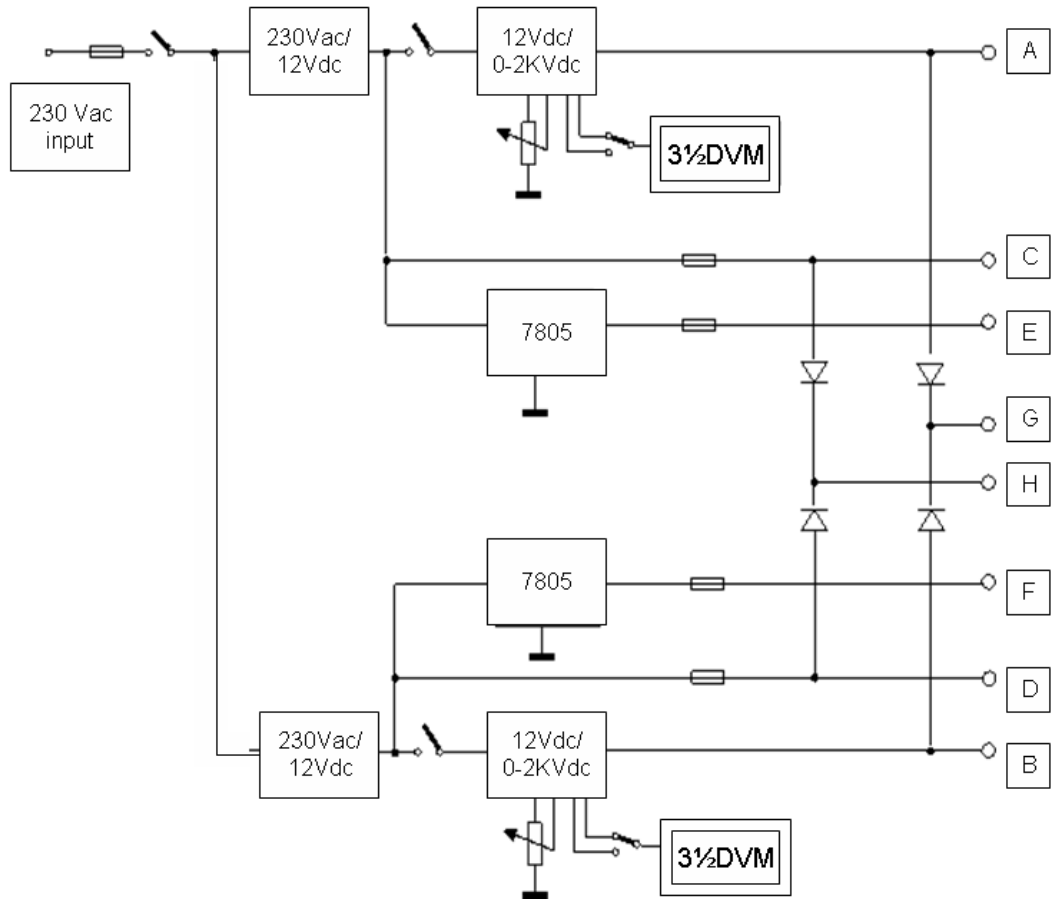

Sample pictures:



ANNEX 3

IDENTIFICATION OF THE TENDERER

(Each service provider, including subcontractor(s) or any member of a consortium or grouping, must complete and sign this identification form)

Call for tender TREN/I1/96-2008

Identity	
Name of the tenderer	
Legal status of the tenderer	
Date of registration	
Country of registration	
Registration number	
VAT number	
Description of statutory social security cover (at the level of the Member State of origin) and non-statutory cover (supplementary professional indemnity insurance) ⁴	
Address	
Address of registered office of tenderer	
Where appropriate, administrative address of tenderer for the purposes of this invitation to tender	
Contact Person	
Surname:	
First name:	
Title (e.g. Dr, Mr, Ms) :	
Position (e.g. manager):	
Telephone number:	
Fax number:	
E-mail address:	

⁴ For natural persons

Legal Representatives	
Names and function of legal representatives and of other representatives of the tenderer who are authorised to sign contracts with third parties	
Declaration by an authorised representative of the organisation⁵ I, the undersigned, certify that the information given in this tender is correct and that the tender is valid.	
Surname: First name:	Signature:

⁵ This person must be included in the list of legal representatives; otherwise the signature on the tender will be invalidated.

ANNEX 4

(to be completed by the tenderer and his or her financial institution)

The tenderer's attention is drawn to the fact that this document is a model and that a specific form for each Member State is available at the following Internet address:

http://ec.europa.eu/budget/execution/ftiers_en.htm

FINANCIAL IDENTIFICATION

<u>ACCOUNT HOLDER</u>	
NAME	<input type="text"/>
ADDRESS	<input type="text"/>
TOWN/CITY	<input type="text"/>
POSTCODE	<input type="text"/>
COUNTRY	<input type="text"/>
VAT NUMBER	<input type="text"/>
CONTACT PERSON	<input type="text"/>
TELEPHONE	<input type="text"/>
FAX	<input type="text"/>
E - MAIL	<input type="text"/>

<u>BANK</u>	
BANK NAME	<input type="text"/>
BRANCH ADDRESS	<input type="text"/>
TOWN/CITY	<input type="text"/>
POSTCODE	<input type="text"/>
COUNTRY	<input type="text"/>
ACCOUNT NUMBER	<input type="text"/>
IBAN (optional)	<input type="text"/>

REMARKS :

BANK STAMP + SIGNATURE of BANK REPRESENTATIVE (Both Obligatory)

DATE + SIGNATURE of ACCOUNT HOLDER : (Obligatory)

ANNEX 5

Legal entity form

Complete the legal entity form, which should be accompanied by a number of supporting documents, available on the Web site:

http://ec.europa.eu/budget/execution/legal_entities_en.htm

Please note that we can only accept either original documents or certified copies, which must be less than 6 months old.

In the case of a grouping, this form must only be provided by the person heading the project.

ANNEX 6

DECLARATION BY THE TENDERER

Each service provider, including subcontractor(s) or any member of a consortium or grouping, must sign this declaration

1. In accordance with Article 93 of the Financial Regulation of the European Communities (Council Regulation 1605/2002 of 25.6.2002) published in Official Journal L 248 of 16 September 2002, I declare on my honour that I am not in any of the following situations which would exclude me from participating in this procurement procedure:
 - a) I am not bankrupt, being wound up or having my affairs administered by the courts, I have not entered into an arrangement with creditors, I have not suspended business activities, I am not the subject of proceedings concerning any such matters, and I am not in any similar situation arising from a similar procedure provided for in legislation or regulations;
 - b) I have not been convicted of an offence concerning my professional judgement by a judgment which has the force of res judicata;
 - c) I have not been found guilty of grave professional misconduct proven by any means which the contracting authority can justify;
 - d) I have not failed to fulfil obligations relating to the payment of social security contributions or the payment of taxes in accordance with the legal provisions of the country in which I am established or with those of the country or the contracting authority or those of the country where the contract is to be performed;
 - e) I have not been the subject of a judgment which has the force of res judicata for fraud, corruption, involvement in a criminal organisation or any other illegal activity detrimental to the Communities' financial interests;
 - f) I am currently not subject to an administrative penalty referred to in Article 96(1) of the Financial Regulation⁶ for being guilty of misrepresentation in supplying the information required by the contracting authority as a condition of participation in a contract procurement procedure or by the authorising officer as a condition of participation in a grant award procedure, for failing to supply this information or for having been declared to be in serious breach of their obligations under contracts or grants covered by the Community budget.
2. In addition, the undersigned declares on his or her honour:
 - a) that on the date of submission of the tender, the company or organisation I do represent and the staff proposed for this tender are not subject to a conflict of interests in the context of this invitation to tender; I undertake to inform the Commission without delay of any change to this situation after the date of submission of the tender.
 - b) that the information provided to the Commission within the context of this invitation to tender is accurate, sincere and complete.

Done at on.....

Name

Title

Signature:

⁶ Council Regulation (EC, Euratom) n° 1605/2002 of 25 June 2002 on the Financial regulation applicable to the general budget of the European Communities, OJ L 248 of 16 September 2002, p. 1, amended by Council Regulation (EC, Euratom) n° 1995/2006 of 13 December 2006, OJ L 390 of 30 December 2006, p.1.

ANNEX 7



EUROPEAN COMMISSION
Directorate General Energy and Transport

Directorate I – Nuclear Safeguards
The Director

DRAFT FRAMEWORK SERVICE CONTRACT

CONTRACT NUMBER – *[complete]*

The European Community (hereinafter referred to as "the Community"), represented by the Commission of the European Communities (hereinafter referred to as "the Commission"), which is represented for the purposes of the signature of this contract by Mr Christian Cleutinx, Director in the Directorate-General for Energy and Transport , Directorate I – Nuclear Safeguards

of the one part,

and

[official name in full]

[official legal form]

[statutory registration number]

[official address in full]

[VAT registration number]

(hereinafter referred to as "the Contractor"), represented for the purposes of the signature of this contract by *[name in full and function,]*

of the other part

HAVE AGREED

the Special Conditions and the General Conditions below and the following Annexes:

Annex I - Tender Specifications (Invitation to Tender No TREN/II/96-2008)

Annex II - Example of the typical "written request"

Annex III- Form of "Purchase Order"

Annex IV – Form of "Record of Technical Acceptance"

Annex V - Tender of the Contractor no. (Complete) of (Complete)

which form an integral part of this contract (hereinafter referred to as "the Contract").

The terms set out in the Special Conditions shall take precedence over those in the other parts of the Contract. The terms set out in the General Conditions shall take precedence over those in the Annexes. The terms set out in the Tender Specifications (Annex I) shall take precedence over those in the Tender (Annex V).

Subject to the above, the several instruments forming part of the Contract are to be taken as mutually explanatory. Ambiguities or discrepancies within or between such parts shall be explained or rectified by a written instruction issued by the Commission; subject to the rights of the Contractor under Article I.7 should he dispute any such instruction.

I – SPECIAL CONDITIONS

ARTICLE I.1 - SUBJECT

I.1.1. This is a framework contract for electrical and electronic services. The contractor will be required to carry out the following:

- a) Production and supply of electronic units
- b) Design, development and counselling
- c) Service, repair and maintenance of electrical and electronic units
- d) Supply of materials and tooling used for the services

I.1.2. The Contractor shall execute the individual work assigned to him by the Purchase order (Annex III) in accordance with Tender Specifications annexed. (Annex I).

I.1.3. Signature of the Contract imposes no obligation on the Commission to purchase. Only implementation of the Contract through purchase order is binding on the Commission.

I.1.4. Once implementation of the Contract has been asked or has commenced, the Contractor shall reply and execute the tasks in accordance with all terms and conditions of the Contract.

ARTICLE I.2 - DURATION

I.2.1. The Contract is valid for 12 months and may be extended twice by 12 months each. The contract shall enter into force on the date on which it is signed by the last contracting party.

I.2.2. Performance of the Contract may under no circumstances begin before the date on which the Contract enters into force.

I.2.3. Delivery of goods and provision of related services to them shall start from date of entry into force of the Contract and according to procedure described in Annex I. Such period may be extended only with the express written agreement of the parties.

ARTICLE I.3 – CONTRACT PRICE

I.3.1 The prices of the services shall be as listed in Annex V.

I.3.2 Prices shall be fixed and not subject to revision during the lifetime of the Contract. Prices shall be expressed in EUR.

I.3.3. Reimbursement of the travel expenses is not applicable.

ARTICLE I.4 – PAYMENTS PERIODS AND FORMALITIES

I.4.1 Payment

Payments under the Contract shall be made in accordance with Article II.4. Payments shall be executed only if the Contractor has fulfilled all his contractual obligations by the date on which the invoice is submitted.

The request for payment shall be admissible if accompanied by

- in accordance with the instructions laid down in Annex I
- the relevant invoice(s), indicating the reference number of the Contract
- Provided the technical acceptance form has been approved by the Commission.

Within 30 days of the date, on which the Technical Acceptance is approved by the Commission, payment corresponding to the relevant invoice(s) shall be made.

[For Contractors established in Belgium, the provisions of the Contract constitute request for VAT exemption no 450, provided that the Contractor indicates in his invoice(s) as follows: “Exonération de la TVA, article 42, paragraphe 3.3 du code de la TVA.” or equivalent indication in Dutch or German language.]

[For Contractors established in Italy, the provisions of the Contract constitute a request for VAT exemption, provided the Contractor includes the following statement in his invoice(s): “Operazione non imponibile ai sensi dell’articolo 72, comma 3) paragrafo 3 del D.P.R. n. 633 del 26/10/1972 come modificato da ultimo dal D.L. n. 323 del 20/06/1996 convertito in Legge n. 425 dell’8/8/1996”.]

I.4.2 The goods shall be delivered at:

To the attention of: *[complete]*

The Contractor shall notify the Commission of the exact date of delivery at least five calendar days in advance. All deliveries shall be made on Commission working days between 09:00 hours and 16:00 hours at the agreed place of delivery.

ARTICLE I.5 – BANK ACCOUNT

Payments shall be made to the Contractor’s bank account denominated in Euro, identified as follows:

Name of bank: *[complete]*
Address of branch: *[complete]*
Exact designation of the account holder: *[complete]*
Full account number including codes: *[complete]*
IBAN code: *[complete]*

ARTICLE I.6 – GENERAL ADMINISTRATIVE PROVISIONS

Any communication relating to the Contract shall be made in writing and shall bear the Contract number. Ordinary mail shall be deemed to have been received by the Commission on the date on which it is registered by the department responsible indicated below. Communications shall be sent to the following addresses:

Commission:

European Commission
Directorate-General for Energy and Transport
Directorate I – Nuclear Safeguards
Unit I1 – Logistical support
L-2920 LUXEMBOURG

Contractor:

Mr/Mrs/Ms [complete]
[Function]
[Company name]
[Official address in full]

ARTICLE I.7– APPLICABLE LAW AND SETTLEMENT OF DISPUTES

I.7.1. The Contract shall be governed by Community law complemented, where necessary, by the national substantive law of Luxembourg.

I.7.2. Any dispute between the parties resulting from the interpretation or application of the Contract which cannot be settled amicably shall be brought before the courts of Luxembourg.

ARTICLE I.8 – DATA PROTECTION

Any personal data included in the Contract shall be processed pursuant to Regulation (EC) No 45/2001 on the protection of individuals with regard to the processing of personal data by the Community institutions and bodies and on the free movement of such data. It shall be processed solely for the purposes of the performance, management and follow-up of the Contract by the entity acting as data controller without prejudice to possible transmission to internal audit services, to the European Court of Auditors, to the Financial Irregularities Panel and/or to the European Anti-Fraud Office (OLAF) for the purposes of safeguarding the financial interests of the Community. The Contractor shall have the right of access to his personal data and the right to rectify any such data that is inaccurate or incomplete. Should the Contractor have any queries concerning the processing of his personal data, he shall address them to the entity acting as data controller. The Contractor shall have right of recourse at any time to the European Data Protection Supervisor.

ARTICLE I.9 – OTHER SPECIAL CONDITIONS

I.9.1 Phases of execution of the Contract

Delivery

a/ Time allowed for delivery

The time allowed for delivery will be established in each purchase order (Annex III)

b/ Consignment note

All consignments shall be accompanied by a consignment note in duplicate, duly signed and dated, giving the Contract number and particulars of the goods delivered. One copy of the consignment note shall be countersigned by the Commission and returned to the Contractor.

Acceptance of the goods after verification

Signing of the consignment note by the Commission, as provided for in subparagraph b) above, is simply an acknowledgement of the fact that the goods have been delivered and in no way implies acceptance.

Acceptance of the goods shall be confirmed by the signing of a certificate to this effect by the Commission contained in Annex IV to this contract.

Non-acceptance of the goods after verification

Where, for reasons attributable to the Contractor, the Commission is unable to declare acceptance of the goods within 45 calendar days of the date of delivery, the Contractor shall be notified in writing within a period of three Commission working days from the deadline for acceptance. The penalties provided for in Article II.1.9 and II.16 may apply to the proportion of the total price corresponding to the goods which are unacceptable.

I.9.2 General provision concerning goods

a) Packaging

The goods shall be packaged in strong boxes or crates or in any other way that ensures that the contents remain intact and prevents damage or deterioration. Packaging, pallets, etc., including contents, shall not weigh more than 500 kg.

Pallets shall be considered as one-way packaging and shall not be returned. Each box shall be clearly labelled with the following information:

- Commission of the European Communities and address for delivery;
- name of Contractor;
- description of contents;
- date of delivery;
- number and date of Contract;
- EC code number of article.

b) Guarantee

The goods shall be guaranteed against all defects in manufacture or materials for one year from the date of Technical acceptance (Annex IV), unless provision is made for a different period in the purchase order. The Contractor shall guarantee that any permits and licences required for manufacturing and selling the goods have been obtained.

The Contractor shall replace at his own expense, within a reasonable time-limit to be determined by agreement between the parties, any items which become damaged or defective in the course of normal use during the guarantee period.

II – GENERAL CONDITIONS

ARTICLE II.1 – PERFORMANCE OF THE CONTRACT

- II.1.1.** The Contractor shall perform the Contract to the highest professional standards. The Contractor shall have sole responsibility for complying with any legal obligations incumbent on him, notably those resulting from employment, tax and social legislation.
- II.1.2.** The Contractor shall have sole responsibility for taking the necessary steps to obtain any permit or licence required for performance of the Contract under the laws and regulations in force at the place where the tasks assigned to him are to be executed.
- II.1.3.** Without prejudice to Article II.3 any reference made to the Contractor's staff in the Contract shall relate exclusively to individuals involved in the performance of the Contract.
- II.1.4.** The Contractor must ensure that any staff performing the Contract have the professional qualifications and experience required for the execution of the tasks assigned to him.
- II.1.5.** The Contractor shall neither represent the Commission nor behave in any way that would give such an impression. The Contractor shall inform third parties that he does not belong to the European public service.
- II.1.6.** The Contractor shall have sole responsibility for the staff who execute the tasks assigned to him.

The Contractor shall make provision for the following employment or service relationships with his staff:

- staff executing the tasks assigned to the Contractor may not be given orders direct by the Commission;
 - the Commission may not under any circumstances be considered to be the staff's employer and the said staff shall undertake not to invoke in respect of the Commission any right arising from the contractual relationship between the Commission and the Contractor.
- II.1.7.** In the event of disruption resulting from the action of a member of the Contractor's staff working on Commission premises or in the event of the expertise of a member of the Contractor's staff failing to correspond to the profile required by the Contract, the Contractor shall replace him without delay. The Commission shall have the right to request the replacement of any such member of staff, stating its reasons for so doing. Replacement staff must have the necessary qualifications and be capable of performing the Contract under the same contractual conditions. The Contractor shall be responsible for any delay in the execution of the tasks assigned to him resulting from the replacement of staff in accordance with this Article.
- II.1.8.** Should any unforeseen event, action or omission directly or indirectly hamper execution of the tasks, either partially or totally, the Contractor shall immediately and on his own initiative record it and report it to the Commission. The report shall include a description of the problem and an indication of the date on which it started and of the remedial action taken

by the Contractor to ensure full compliance with his obligations under the Contract. In such event the Contractor shall give priority to solving the problem rather than determining liability.

- II.1.9.** Should the Contractor fail to perform his obligations under the Contract in accordance with the provisions laid down therein, the Commission may - without prejudice to its right to terminate the Contract - reduce or recover payments in proportion to the scale of the failure. In addition, the Commission may impose penalties or liquidated damages provided for in Article II.16.

ARTICLE II.2 – LIABILITY

- II.2.1.** The Commission shall not be liable for damage sustained by the Contractor in performance of the Contract except in the event of wilful misconduct or gross negligence on the part of the Commission.
- II.2.2.** The Contractor shall be liable for any loss or damage caused by himself in performance of the Contract, including in the event of subcontracting under Article II.13. The Commission shall not be liable for any act or default on the part of the Contractor in performance of the Contract.
- II.2.3.** The Contractor shall provide compensation in the event of any action, claim or proceeding brought against the Commission by a third party as a result of damage caused by the Contractor in performance of the Contract.
- II.2.4.** In the event of any action brought by a third party against the Commission in connection with performance of the Contract, the Contractor shall assist the Commission. Expenditure incurred by the Contractor to this end may be borne by the Commission.
- II.2.5.** The Contractor shall take out insurance against risks and damage relating to performance of the Contract if required by the relevant applicable legislation. He shall take out supplementary insurance as reasonably required by standard practice in the industry. A copy of all the relevant insurance contracts shall be sent to the Commission should it so request.

ARTICLE II.3 - CONFLICT OF INTERESTS

- II.3.1.** The Contractor shall take all necessary measures to prevent any situation that could compromise the impartial and objective performance of the Contract. Such conflict of interests could arise in particular as a result of economic interest, political or national affinity, family or emotional ties, or any other relevant connection or shared interest. Any conflict of interests which could arise during performance of the Contract must be notified to the Commission in writing without delay. In the event of such conflict, the Contractor shall immediately take all necessary steps to resolve it.

The Commission reserves the right to verify that such measures are adequate and may require additional measures to be taken, if necessary, within a time limit which it shall set. The Contractor shall ensure that his staff, board and directors are not placed in a situation which could give rise to conflict of interests. Without prejudice to Article II.1 the Contractor shall replace, immediately and without compensation from the Commission, any member of his staff exposed to such a situation.

II.3.2. The Contractor shall abstain from any contact likely to compromise his independence.

II.3.3. The Contractor declares:

- that he has not made and will not make any offer of any type whatsoever from which an advantage can be derived under the Contract,
- that he has not granted and will not grant, has not sought and will not seek, has not attempted and will not attempt to obtain, and has not accepted and will not accept, any advantage, financial or in kind, to or from any party whatsoever, where such advantage constitutes an illegal practice or involves corruption, either directly or indirectly, inasmuch as it is an incentive or reward relating to performance of the Contract.

II.3.4. The Contractor shall pass on all the relevant obligations in writing to his staff, board, and directors as well as to third parties involved in performance of the Contract. A copy of the instructions given and the undertakings made in this respect shall be sent to the Commission should it so request.

ARTICLE II.4 – PAYMENTS

II.4.1. Pre-financing :

Where required by Article I.4.1, the Contractor shall provide a financial guarantee in the form of a bank guarantee or equivalent supplied by a bank or an authorised financial institution (guarantor) equal to the amount indicated in the same Article to cover pre-financing under the Contract. Such guarantee may be replaced by a joint and several guarantee by a third party.

The guarantor shall pay to the Commission at its request an amount corresponding to payments made by it to the Contractor which have not yet been covered by equivalent work on his part.

The guarantor shall stand as first-call guarantor and shall not require the Commission to have recourse against the principal debtor (the Contractor).

The guarantee shall specify that it enters into force at the latest on the date on which the Contractor receives the pre-financing. The Commission shall release the guarantor from its obligations as soon as the Contractor has demonstrated that any pre-financing has been covered by equivalent work. The guarantee shall be retained until the pre-financing has been deducted from interim payments or payment of the balance to the Contractor. It shall be released the following month. The cost of providing such guarantee shall be borne by the Contractor.

II.4.2. Interim payment:

At the end of each of the periods indicated in Annex I the Contractor shall submit to the Commission a formal request for payment accompanied by those of the following documents which are provided for in the Special Conditions:

- an interim technical report in accordance with the instructions laid down in Annex I;
- the relevant invoices indicating the reference number of the Contract to which they refer;
- statements of reimbursable expenses in accordance with Article II.7.

If the report is a condition for payment, on receipt the Commission shall have the period of time indicated in the Special Conditions in which:

- to approve it, with or without comments or reservations, or suspend such period and request additional information; or

- to reject it and request a new report.

If the Commission does not react within this period, the report shall be deemed to have been approved. Approval of the report does not imply recognition either of its regularity or of the authenticity, completeness or correctness of the declarations or information enclosed.

Where the Commission requests a new report because the one previously submitted has been rejected, this shall be submitted within the period of time indicated in the Special Conditions. The new report shall likewise be subject to the above provisions.

II.4.3. Payment of the balance:

Within sixty days of completion of the tasks referred to in Annex I the Contractor shall submit to the Commission a formal request for payment accompanied by those of the following documents which are provided for in the Special Conditions:

- a final technical report in accordance with the instructions laid down in Annex I;
- the relevant invoices indicating the reference number of the Contract to which they refer;
- statements of reimbursable expenses in accordance with Article II.7.

If the report is a condition for payment, on receipt the Commission shall have the period of time indicated in the Special Conditions in which:

- to approve it, with or without comments or reservations, or suspend such period and request additional information; or
- to reject it and request a new report.

If the Commission does not react within this period, the report shall be deemed to have been approved. Approval of the report does not imply recognition either of its regularity or of the authenticity, completeness or correctness of the declarations and information enclosed.

Where the Commission requests a new report because the one previously submitted has been rejected, this shall be submitted within the period of time indicated in the Special Conditions. The new report shall likewise be subject to the above provisions.

ARTICLE II.5 – GENERAL PROVISIONS CONCERNING PAYMENTS

II.5.1. Payments shall be deemed to have been made on the date on which the Commission's account is debited.

II.5.2. The payment periods referred to in Article I.4 may be suspended by the Commission at any time if it informs the Contractor that his payment request is not admissible, either because the amount is not due or because the necessary supporting documents have not been properly produced. In case of doubt on the eligibility of the expenditure indicated in the payment request, the Commission may suspend the time limit for payment for the purpose of further verification, including an on-the-spot check, in order to ascertain, prior to payment, that the expenditure is eligible.

The Commission shall notify the Contractor accordingly by registered letter with acknowledgment of receipt or equivalent. Suspension shall take effect from the date of dispatch of the letter. The remainder of the period referred to in Article I.4 shall begin to run again once the suspension has been lifted.

II.5.3. In the event of late payment the Contractor shall be entitled to claim interest, provided the calculated interest exceeds EUR 200. However, in the event of payment due before 1st January 2008, the Contractor may claim interest only within two months of receiving the payment. In case interest does not exceed EUR 200, the Contractor may claim interest within two months of receiving the payment. Interest shall be calculated at the rate applied by the European Central Bank to its most recent main refinancing operations (“*the reference rate*”) plus seven percentage points (“*the margin*”). The reference rate in force on the first day of the month in which the payment is due shall apply. Such interest rate is published in the C series of the Official Journal of the European Union. Interest shall be payable for the period elapsing from the calendar day following expiry of the time limit for payment up to the day of payment. Suspension of payment by the Commission may not be deemed to constitute late payment.

ARTICLE II.6 – RECOVERY

II.6.1. If total payments made exceed the amount actually due under the Contract or if recovery is justified in accordance with the terms of the Contract, the Contractor shall reimburse the appropriate amount in euro on receipt of the debit note, in the manner and within the time limits set by the Commission.

II.6.2. In the event of failure to pay by the deadline specified in the request for reimbursement, the sum due shall bear interest at the rate indicated in Article II.5.3. Interest shall be payable from the calendar day following the due date up to the calendar day on which the debt is repaid in full.

II.6.3. The Commission may, after informing the Contractor, recover amounts established as certain, of a fixed amount and due by offsetting, in cases where the Contractor also has a claim on the Communities that is certain, of a fixed amount and due. The Commission may also claim against the guarantee, where provided for.

ARTICLE II.7 - REIMBURSEMENTS

II.7.1. Where provided by the Special Conditions or by Annex I, the Commission shall reimburse the expenses which are directly connected with execution of the tasks on production of original supporting documents, including receipts and used tickets.

II.7.2. Travel and subsistence expenses shall be reimbursed, where appropriate, on the basis of the shortest itinerary.

II.7.3. Travel expenses shall be reimbursed as follows:

- a) travel by air shall be reimbursed up to the maximum cost of an economy class ticket at the time of the reservation;
- b) travel by boat or rail shall be reimbursed up to the maximum cost of a first class ticket;
- c) travel by car shall be reimbursed at the rate of one first class rail ticket for the same journey and on the same day;
- d) travel outside Community territory shall be reimbursed under the general conditions stated above provided the Commission has given its prior written agreement.

II.7.4. Subsistence expenses shall be reimbursed on the basis of a daily allowance as follows:

- a) for journeys of less than 200 km (return trip) no subsistence allowance shall be payable;
- b) daily subsistence allowance shall be payable only on receipt of a supporting document proving that the person concerned was present at the place of destination;
- c) daily subsistence allowance shall take the form of a flat-rate payment to cover all subsistence expenses, including accommodation, meals, local transport, insurance and sundries;
- d) daily subsistence allowance, where applicable, shall be reimbursed at the rate specified in Article I.3.3.

II.7.5. The cost of shipment of equipment or unaccompanied luggage shall be reimbursed provided the Commission has given prior written authorisation.

ARTICLE II.8 – OWNERSHIP OF THE RESULTS - INTELLECTUAL AND INDUSTRIAL PROPERTY

Any results or rights thereon, including copyright and other intellectual or industrial property rights, obtained in performance of the Contract, shall be owned solely by the Community, which may use, publish, assign or transfer them as it sees fit, without geographical or other limitation, except where industrial or intellectual property rights exist prior to the Contract being entered into.

ARTICLE II.9 – CONFIDENTIALITY

II.9.1. The Contractor undertakes to treat in the strictest confidence and not make use of or divulge to third parties any information or documents which are linked to performance of the Contract. The Contractor shall continue to be bound by this undertaking after completion of the tasks.

II.9.2. The Contractor shall obtain from each member of his staff, board and directors an undertaking that they will respect the confidentiality of any information which is linked, directly or indirectly, to execution of the tasks and that they will not divulge to third parties or use for their own benefit or that of any third party any document or information not available publicly, even after completion of the tasks.

ARTICLE II.10 - USE, DISTRIBUTION AND PUBLICATION OF INFORMATION

II.10.1. The Contractor shall authorise the Commission to process, use, distribute and publish, for whatever purpose, by whatever means and on whatever medium, any data contained in or relating to the Contract, in particular the identity of the Contractor, the subject matter, the duration, the amount paid and the reports. Where personal data is concerned, Article I.8 shall apply.

II.10.2. Unless otherwise provided by the Special Conditions, the Commission shall not be required to distribute or publish documents or information supplied in performance of the Contract. If it decides not to publish the documents or information supplied, the Contractor may not have them distributed or published elsewhere without prior written authorisation from the Commission.

- II.10.3.** Any distribution or publication of information relating to the Contract by the Contractor shall require prior written authorisation from the Commission and shall mention the amount paid by the Community. It shall state that the opinions expressed are those of the Contractor only and do not represent the Commission's official position.
- II.10.4.** The use of information obtained by the Contractor in the course of the Contract for purposes other than its performance shall be forbidden, unless the Commission has specifically given prior written authorisation to the contrary.

ARTICLE II. 11 – TAXATION

- II.11.1.** The Contractor shall have sole responsibility for compliance with the tax laws which apply to him. Failure to comply shall make the relevant invoices invalid.
- II.11.2.** The Contractor recognises that the Commission is, as a rule, exempt from all taxes and duties, including value added tax (VAT), pursuant to the provisions of Articles 3 and 4 of the Protocol on the Privileges and Immunities of the European Communities.
- II.11.3.** The Contractor shall accordingly complete the necessary formalities with the relevant authorities to ensure that the goods and services required for performance of the Contract are exempt from taxes and duties, including VAT.
- II.11.4.** Invoices presented by the Contractor shall indicate his place of taxation for VAT purposes and shall specify separately the amounts not including VAT and the amounts including VAT.

ARTICLE II.12 – FORCE MAJEURE

- II.12.1.** Force majeure shall mean any unforeseeable and exceptional situation or event beyond the control of the contracting parties which prevents either of them from performing any of their obligations under the Contract, was not due to error or negligence on their part or on the part of a subcontractor, and could not have been avoided by the exercise of due diligence. Defects in equipment or material or delays in making it available, labour disputes, strikes or financial problems cannot be invoked as force majeure unless they stem directly from a relevant case of force majeure.
- II.12.2.** Without prejudice to the provisions of Article II.1.8, if either contracting party is faced with force majeure, it shall notify the other party without delay by registered letter with acknowledgment of receipt or equivalent, stating the nature, likely duration and foreseeable effects.
- II.12.3.** Neither contracting party shall be held in breach of its contractual obligations if it has been prevented from performing them by force majeure. Where the Contractor is unable to perform his contractual obligations owing to force majeure, he shall have the right to remuneration only for tasks actually executed.
- II.12.4.** The contracting parties shall take the necessary measures to reduce damage to a minimum.

ARTICLE II.13 – SUBCONTRACTING

- II.13.1.** The Contractor shall not subcontract without prior written authorisation from the Commission nor cause the Contract to be performed in fact by third parties.

II.13.2. Even where the Commission authorises the Contractor to subcontract to third parties, he shall none the less remain bound by his obligations to the Commission under the Contract and shall bear exclusive liability for proper performance of the Contract.

II.13.3. The Contractor shall make sure that the subcontract does not affect rights and guarantees to which the Commission is entitled by virtue of the Contract, notably Article II.17.

ARTICLE II.14 – ASSIGNMENT

II.14.1. The Contractor shall not assign the rights and obligations arising from the Contract, in whole or in part, without prior written authorisation from the Commission.

II.14.2. In the absence of the authorisation referred to in 1 above, or in the event of failure to observe the terms thereof, assignment by the Contractor shall not be enforceable against and shall have no effect on the Commission.

ARTICLE II.15 – TERMINATION BY THE COMMISSION

II.15.1. The Commission may terminate the Contract in the following circumstances:

- (a) where the Contractor is being wound up, is having his affairs administered by the courts, has entered into an arrangement with creditors, has suspended business activities, is the subject of proceedings concerning those matters, or is in any analogous situation arising from a similar procedure provided for in national legislation or regulations;
- (b) where the Contractor has been convicted of an offence concerning his professional conduct by a judgment which has the force of *res judicata*;
- (c) where the Contractor has been guilty of grave professional misconduct proven by any means which the contracting authority can justify;
- (d) where the Contractor has not fulfilled obligations relating to the payment of social security contributions or the payment of taxes in accordance with the legal provisions of the country in which he is established or with those of the country applicable to the Contract or those of the country where the Contract is to be performed;
- (e) where the Commission seriously suspects the Contractor of fraud, corruption, involvement in a criminal organisation or any other illegal activity detrimental to the Communities' financial interests;
- (f) where the Contractor is in breach of his obligations under Article II.3;
- (g) where the Contractor was guilty of misrepresentation in supplying the information required by the Commission as a condition of participation in the Contract procedure or failed to supply this information;
- (h) where a change in the Contractor's legal, financial, technical or organisational situation could, in the Commission's opinion, have a significant effect on the performance of the Contract;

- (i) where execution of the tasks has not actually commenced within three months⁷ of the date foreseen, and the new date proposed, if any, is considered unacceptable by the Commission;
- (j) where the Contractor is unable, through his own fault, to obtain any permit or licence required for performance of the Contract;
- (k) where the Contractor, after receiving formal notice in writing to comply, specifying the nature of the alleged failure, and after being given the opportunity to remedy the failure within a reasonable period following receipt of the formal notice, remains in serious breach of his contractual obligations.

II.15.2. In case of force majeure, notified in accordance with Article II.12, either contracting party may terminate the Contract, where performance thereof cannot be ensured for a period corresponding to at least to one fifth of the period laid down in Article I.2.3.

II.15.3. Prior to termination under point e), h) or k), the Contractor shall be given the opportunity to submit his observations.

Termination shall take effect on the date on which a registered letter with acknowledgment of receipt terminating the Contract is received by the Contractor, or on any other date indicated in the letter of termination.

II.15.4. Consequences of termination:

In the event of the Commission terminating the Contract in accordance with this Article and without prejudice to any other measures provided for in the Contract, the Contractor shall waive any claim for consequential damages, including any loss of anticipated profits for uncompleted work. On receipt of the letter terminating the Contract, the Contractor shall take all appropriate measures to minimise costs, prevent damage, and cancel or reduce his commitments. He shall draw up the documents required by the Special Conditions for the tasks executed up to the date on which termination takes effect, within a period not exceeding sixty days from that date.

The Commission may claim compensation for any damage suffered and recover any sums paid to the Contractor under the Contract.

On termination the Commission may engage any other contractor to complete the services. The Commission shall be entitled to claim from the Contractor all extra costs incurred in making good and completing the services, without prejudice to any other rights or guarantees it has under the Contract.

ARTICLE II.16 – LIQUIDATED DAMAGES

Should the Contractor fail to perform his obligations under the Contract within the time limits set by the Contract, then, without prejudice to the Contractor's actual or potential liability incurred in relation to the Contract or to the Commission's right to terminate the Contract, the Commission may decide to impose liquidated damages of 0.2% of the amount specified in Article I.3.1 per calendar day of delay. The Contractor may submit arguments against this decision within thirty days of notification by registered letter with acknowledgement of receipt or equivalent. In the absence of reaction on his part or of written withdrawal by the Commission within thirty days of the receipt of such arguments, the decision imposing the liquidated damages shall become enforceable. These

liquidated damages shall not be imposed where there is provision for interest for late completion. The Commission and the Contractor expressly acknowledge and agree that any sums payable under this Article are in the nature of liquidated damages and not penalties, and represent a reasonable estimate of fair compensation for the losses that may be reasonably anticipated from such failure to perform obligations.

ARTICLE II.17 – CHECKS AND AUDITS

- II.17.1.** Pursuant to Article 142 of the Financial Regulation applicable to the general budget of the European Communities, the European Court of Auditors shall be empowered to audit the documents held by the natural or legal persons receiving payments from the budget of the European Communities from signature of the Contract up to five years after payment of the balance.
- II.17.2.** The Commission or an outside body of its choice shall have the same rights as the European Court of Auditors for the purpose of checks and audits limited to compliance with contractual obligations from signature of the Contract up to five years after payment of the balance.
- II.17.3.** In addition, the European Anti Fraud Office may carry out on-the-spot checks and inspections in accordance with Council Regulation (Euratom, EC) No 2185/96 and Parliament and Council Regulation (EC) No 1073/1999 from signature of the Contract up to five years after payment of the balance.

ARTICLE II.18 – AMENDMENTS

Any amendment to the Contract shall be the subject of a written agreement concluded by the contracting parties. An oral agreement shall not be binding on the contracting parties.

ARTICLE II.19 – SUSPENSION OF THE CONTRACT

Without prejudice to the Commission's right to terminate the Contract, the Commission may at any time and for any reason suspend execution of the tasks under the Contract or any part thereof. Suspension shall take effect on the day the Contractor receives notification by registered letter with acknowledgment of receipt or equivalent, or at a later date where the notification so provides. The Commission may at any time following suspension give notice to the Contractor to resume the work suspended. The Contractor shall not be entitled to claim compensation on account of suspension of the Contract or of part thereof.

SIGNATURES

For the Contractor,
[Company name/forename/surname/function]

For the Commission,
[forename/surname/function]

signature[s]: _____

signature[s]: _____

Done at [Luxembourg], [date]

Done at [Luxembourg], [date]

In duplicate in English.

ANNEX I

Tender Specifications (Invitation to Tender No TREN/I1/96-2008)

ANNEX II

Example of a typical written request



EUROPEAN COMMISSION
DIRECTORATE-GENERAL FOR ENERGY AND TRANSPORT

DIRECTORATE I - Nuclear Safeguards
Concepts, planning & evaluation of inspections; logistical support

FAX

To: **Telephone:**

From: Mr xxxxx **Telephone:** (352) 4301-xxxxx
DG TREN I.1 **Fax:** (352) 4301-xxxxx
Complexe Euroforum
Zone d'activité Cloche d'Or
1, rue Henri Schnadt
L-2920 Luxembourg

Number of pages:

Subject:

Dear Sir/Madam,

Please submit to us your best offer by fax, within XX calendar days from the date of sending of this fax, for technical specification

xxxxxxxxxx.

Offer should be drawn up on the following basis:

- The quotations will be required to show the number of hours of each category to be used, the cost of materials, the total cost to carry out the work.
- be expressed in Euro (€), excluding VAT,
- be calculated on a delivery free-to-our-address basis,
- payment delay of **30 days**,
- it should be calculated with regard to the fact that, under the provisions of the Protocol and Privileges and Immunities in annex to the Treaty of 8 April 1965 establishing a single Council and a single Commission of the European Communities, the Commission is exempt from all duties and taxes.

The offer should have a validity of **180 days** and also indicate the VAT number.

More information can be collected from M. xxxxx (phone n°: +352 4301 xxxxx).

Yours faithfully,

ANNEX III

Purchase Order Form

	EUROPEAN COMMISSION	PURCHASE ORDER (to be mentioned in all correspondence)	Number of sheets	Sheet No	Date and reference of your quote
Directorate-General for Energy and Transport TREN I.1 L-2930 Luxembourg Tel.: XXXXXX Fax: XXXXXX		Contractor code: XXXX Country of origin: XXXX Currency of payment: EUR Code country of origin/currency	XXXXXX	XXXXXX	VAT: XXXXXXXX

This purchase contract is governed by the 2003 General Conditions published on the Internet at: http://europa.eu.int/comm/budget/infos/index_en.htm

This purchase order constitutes acceptance of the Contractor's quote submitted on XX/XX/XXXX by mail with reference no XXXX and is valid only if the delivery/performance dates stipulated below are complied with.

By agreeing to this contract, the Contractor states that he is familiar with and accepts the 2003 General Conditions and waives all other terms of sale or performance of services.

DESCRIPTION OF THE GOODS OR SERVICES	UNIT	QUANTITY	PRICE in €	
			UNIT PRICE	TOTAL
<p><i>Your invoices (2 copies) should be sent to:</i></p> <p>European Commission DG TREN - Financial & Contractual Cell Complexe Euroforum rue Henry M. Schnadt 1 Zone d'activité Cloche d'Or L - 2530 Luxembourg</p> <p><i>indicating the reference no of the purchase order</i></p>				
<p>Pursuant to the provisions of Articles 3 and 4 of the Protocol on the Privileges and Immunities of the European Communities, the Commission is exempt from all taxes and dues, including value added tax, on payments due in respect of this Contract. [In Belgium, use of this Contract constitutes a request for VAT exemption. The invoice must include the following statement: "Commande destinée à l'usage officiel des Communautés Européennes, Exonération de la TVA; article 42 § 3,3 du code de la TVA".]</p>				
			TOTAL :	
<p>Place of delivery/performance and/or Incoterm and opening hours: DG TREN, Bâtiment Euroforum, 1 rue Schnadt, Cloche d'Or, Luxembourg</p> <p>Delivery/performance dates: Payment: 30 days from receipt of the invoice</p> <p>Contractor's bank account: XXXXXX</p>	Contractor's signature			
			Name:	
			Position:	
			Date:	

Acceptance of the quote by the Commission:

Date of issue :
 Signature:

The request for payment shall be admissible only if the Contractor returns a signed copy of this purchase order with the invoice.

This Contract shall be governed by Luxembourg law and any dispute shall be brought before the courts of Luxembourg.

ANNEX IV



EUROPEAN COMMISSION
DIRECTORATE-GENERAL FOR ENERGY AND TRANSPORT
DIRECTORATE

Luxembourg,

RECORD OF TECHNICAL ACCEPTANCE

Contract reference:

Contract subject: The technical approval related to the above mentioned contract has taken place at.

This technical approval was:

- a complete technical approval:
- a partial technical approval as described below:

and was concluded:

- without any remarks
- with the following remarks:

Nr.	Remark	Date for final approval

	For the Contractor (if present)	For European Commission (technical responsible)
Date		
Name		
Signature		

Copies (to be sent by the technical responsible):

ANNEX V

Contractor's Tender (No [complete] of [complete])